

**Oldcastle BuildingEnvelope®**

## *RELIANCE-SS CURTAIN WALL INSTALLATION AND GLAZING MANUAL*

**Note:**

The installation details found in this package are generic and are for representation only with the intent of giving the installation team a visual representation as to how the assemblies typically install. The shop drawings and details are the governing documents and as such this package is to be used only as a resource.

Follow sealant manufacturers recommendations for use and application of structural silicone sealant and weather seal silicone sealant.

Note: Customer / Project quality assurance procedures are separate documents and are to be followed in conjunction with this manual.

# RELIANCE™-SS CURTAIN WALL INSTALLATION MANUAL

## TABLE OF CONTENTS

<b>General Information</b>	
<i>Product Use</i>	4
<i>Protection and Storage</i>	6
<i>Check Material</i>	6
<i>Field Conditions</i>	6
<i>Cleaning Materials</i>	7
<i>Expansion Joints</i>	7
<i>Suggestions for Improving System Thermal Performance</i>	7
<b>Installation Types</b>	<b>8</b>
<b>Section 1: Frame Fabrication</b>	<b>9-13</b>
1.1 <i>Measuring Opening</i>	9
1.2 <i>Cutting Material</i>	9
1.3 <i>Vertical Mullion Fabrication</i>	10
1.4 <i>Installing End Caps at Jambs</i>	10
1.5 <i>Weep Hole Fabrication</i>	10
1.6 <i>Additional Pressure Plate Holes</i>	10
1.7 <i>Vertical Mullion Prep for Mull Cap</i>	13
1.8 <i>Access Holes in Head &amp; Sill</i>	13
1.9 <i>SSG Glazing Adaptors</i>	13
<b>Section 2: Frame Assembly</b>	<b>14-19</b>
2.1 <i>Layout for Bay Assembly</i>	14
2.2 <i>Assembling Bays</i>	14
2.4 <i>Installing Splice Sleeves</i>	14
2.5 <i>Installing Zone Plugs</i>	14
2.6 <i>Applying Vertical Mullion Seal</i>	16
2.8 <i>Installing Interior (Frame) Gaskets for Field Glazing</i>	16
2.9 <i>Installing Interior (Frame) Gaskets for Shop Glazing</i>	16
2.10 <i>Pre-Glazing Instructions</i>	16
<b>Section 3: Frame Installation</b>	<b>20-24</b>
3.1 <i>Frame Anchoring Options</i>	20
3.2 <i>First Bay Installation</i>	20
3.3 <i>Sealing Vertical Mullion Halves</i>	20
3.4 <i>Second Bay Installation</i>	20
3.5 <i>Setting Mullion Halves</i>	20
3.6 <i>Dimension Check</i>	20
3.7 <i>Setting Mullion Splices</i>	20
3.8 <i>SSG Mullion Zone Bridge Installation</i>	20
3.9 <i>Installing End Caps at Intermediate Vertical Mullions</i>	20
3.10 <i>Applying Perimeter Seal</i>	20

# RELIANCE™-SS CURTAIN WALL INSTALLATION MANUAL

## TABLE OF CONTENTS - cont'd.

<b>Section 4: Glazing</b>	<b>25-30</b>
4.1 <i>Pressure Plate Gasket Installation</i>	25
4.2 <i>Thermal Spacer Installation</i>	26
4.3 <i>Interior Gasket Sealing</i>	26
4.4 <i>Setting Block Placement</i>	26
4.5 <i>Setting Glass</i>	26
4.6 <i>Temporary Retainer Installation</i>	26
<i>Face Cap Installation</i>	27
4.7 <i>Anti-Walk Block Installation</i>	28
4.9 <i>Sealing for Vertical Pressure Plates</i>	28
4.10 <i>Vertical Pressure Plate Installation</i>	29
4.11 <i>Horizontal Pressure Plate Installation</i>	29
4.12 <i>Final Check of Pressure Plate Torque</i>	29
4.13 <i>Vertical Face Cover Installation</i>	29
4.14 <i>Sealing Tops of Vertical Mullions</i>	29
4.15 <i>Sealing Horizontal Pressure Plates</i>	30
4.16 <i>Horizontal Face Cover Installation</i>	30
<b>Section 5: Supplemental Instructions</b>	<b>31-47</b>
<i>Transition Glazing</i>	31
<i>Vertical Splicing</i>	32
<i>Entrance Frames</i>	35
<i>Reglazing Procedures</i>	39
<i>Mullion Reinforcing</i>	40
<i>Corner Mullions</i>	40
<b>Section 6: Parts List</b>	<b>48-51</b>

# RELIANCE™-SS CURTAIN WALL INSTALLATION MANUAL

## GENERAL INFORMATION

### PRODUCT USE

The **Reliance™-SS** curtain wall system is intended for fabrication, assembly, sealing, installation and glazing by professionals with appropriate knowledge and experience of the system(s) and their incorporation into various building conditions.

**Consult sealant manufacturer for review and recommendation of sealant application. Follow sealant manufacturer's recommendations and literature for proper installation.**

The fabrication and installation of a structural silicone-glazed (SSG) or wet glazed system requires more technical knowledge and experience than is required for a conventional pressure-glazed or dry glazed system. The glazing contractor should take all steps as outlined and required by the structural silicone sealant manufacturer, glass fabricator, framing manufacturer, and the project professional engineer of record as well as follow local building code requirements and industry best practices to ensure the proper installation and safe performance of the SSG system.

The glazing contractor for each project needs to ensure compliance with each step, including, but not limited to, design reviews, formal adhesion testing, formal compatibility testing, project specification compliance, validating procedures, field testing, and quality control validation of installed product and surrounding conditions.

Testing of component materials for use in a SSG or wet glazed system is mandatory to fulfill project specifications and warranty requirements and must be submitted by the glazing contractor to the structural silicone manufacturer. All materials that comprise the structural silicone joint, such as the framing system (with the job-specific finish) and job-specific glass must be tested by the structural silicone manufacturer for compatibility and adhesion. All other accessory materials in contact with the structural silicone, such as setting blocks, spacers, gaskets, sweeps, air seals and expansion joints, must also be submitted to the silicone sealant manufacturer for compatibility testing.

To ensure that nothing has changed in formulation or chemistry since the initial tests, subsequent testing during periodic time frames of the project is to be conducted to confirm continued acceptance of the material for use on the project. To ensure the structural performance and integrity of the insulating glass unit (IGU), the glazing contractor must submit the project shop drawings to the glass fabricator to obtain approval for use of their product(s) in any 2, 3 or 4-sided SSG applications.

Quality control procedures for field glazing are to be increased beyond those required for shop glazing. Job conditions will normally have dust, dirt, and other construction debris on the surfaces where structural silicone is to be applied. Great care should be exercised in cleaning and preparing these surfaces for silicone application. The recommendations of the silicone sealant manufacturer are to be strictly enforced and followed. The fabrication and installation of the SSG system and its components, whether shop or field glazed, should be governed by a quality control program, and all steps, procedures, and test reports should be documented throughout the project.

Prior to installation of any SSG system, refer to industry documents (e.g., AAMA Curtain Wall Design Guide Manual, ASTM C1401-14, and AAMA SSGDG-17) for detailed instructions and recommendations.

# RELIANCE™-SS CURTAIN WALL INSTALLATION MANUAL

**THE GLAZING CONTRACTOR ASSUMES FULL RESPONSIBILITY FOR ENSURING COMPLIANCE WITH THE ABOVE AND ASSUMES FULL LIABILITY FOR ANY ISSUES ARISING FROM NONCOMPLIANCE.**

## GLAZING PRACTICES

The air and water performance of the **Reliance™-SS** curtain wall system is directly related to the completeness and integrity of the installation process, including but not limited to the assembly seals of the framing joinery, the installed glazing gaskets, and the alignment of the framing joinery glazing plane. Before glazing, verify the glazing pocket width and glazing infill thickness, as both must be in tolerance to assure adequate edge pressure and to achieve the desired air and water performance levels. (In general, framing systems utilizing 1" insulating glass are designed to accommodate a thickness variance of +/- 1/32"). Note: Excessive pressure can cause glass breakage and/or IGU failure. Consult the glass manufacturer for their recommended edge pressure per lineal inch. To achieve the designed and tested air and water performance, best practices include:

1. Surfaces to be sealed should be cleaned with isopropyl alcohol or solvent and dried as recommended by sealant manufacturer to remove all dirt and cutting oils. Sealant at shear blocks should be a minimum 3/16" diameter nominal placed completely around the top, face and bottom of the shear block without gaps in the sealant. Exposed surfaces should be cleaned after installing the horizontal. Inspect joint for complete sealant contact, especially where the horizontal meets the face of the vertical member. Repair joint as required.
2. Glazing gaskets should be cut ¼" longer per foot, and lay flat, preferably for 24 hours.
3. Gaskets should be cut as single monolithic pieces and "crowded" during their installation to avoid corner gaps caused by post-installation relaxation.
4. The interior glazing gasket should be installed so as to avoid stretching, buckles, or tears.
5. Corners must be cut square, and at a slight angle when required to conform to the bevel on the intersecting gasket; sealed and butted together.
6. Gasket corner joinery must also be crowded, and sealant applied onto the gasket contact frame surface and into gasket reglet raceway where applicable.
7. Gasket corner seals are to be done just prior to installing glass, while the sealant is still wet and uncured, and ensure exterior gaskets are installed so as to place the glass into it's final in service condition and allow the sealant to conform to optimum configuration. Note: If the sealant cures prior to glazing, the cured sealant could create excessive edge pressure onto the glass and has the potential to cause glass breakage.
8. The glass must be checked for squareness, size dimension, and thickness along the edges paying attention to any variances from center edge to corner edge.
9. Check the placement of the installed glass and verify there is proper edge bite into the pocket, and proper edge clearance from framing elements.
10. After sealant has set and a representative amount of the wall has been installed and glazed (250 square feet or more) run a water hose test in accordance with AAMA 501.2 specifications to check installation. On large projects the hose test should be repeated during the glazing operation. Consult and follow NGA's GANA Manual and FGMA Glazing Manual for proper glazing technique and procedure.

Variations on the details shown are inevitable and are not the responsibility of Oldcastle BuildingEnvelope when drawn by others. Oldcastle BuildingEnvelope strongly encourages its customers to utilize Oldcastle BuildingEnvelope® supplied calculations and shop drawings.

# RELIANCE™-SS CURTAIN WALL INSTALLATION MANUAL

For Structural Silicone Glazing applications, the stress on the silicone should not exceed 20 PSI. Consult sealant manufacturer for specific applications to ensure proper loading on silicone joint. Alternate spacer gaskets are available to accommodate larger sealant contact widths. Consult your nearest Oldcastle BuildingEnvelope facility for assistance.

Consult glass manufacturer for correct setting block location and length for glass sizes in excess of 40 sq.ft.

## BUILDING CODES

Oldcastle BuildingEnvelope® does not control the application nor selection of its product configurations, sealant, or glazing materials, and assumes no responsibility thereof. It is the responsibility of the owner, architect, and installer to make these selections in strict compliance with applicable laws and building codes.

## PROTECTION AND STORAGE

Handle all material carefully. Dropped or damaged materials will not engage properly and may result in system failures. Stack with adequate separation so the material will not rub together. Store material off the ground, protecting against the elements and other construction hazards by using a well ventilated covering. Remove material from package if wet or located in a damp area. For further guidelines consult AAMA publication CW-10 *“Care and Handling of Architectural Aluminum From Shop to Site.”*

## CHECK MATERIAL

Check glass dimensions for overall size as well as thickness. Oldcastle BuildingEnvelope cannot be held responsible for gaskets that are not watertight due to extreme glass tolerances.

Check all material upon arrival at job site for quality and to determine any shipping damage.

Using the contract documents, completely check the surrounding conditions that will receive your materials. Notify the general contractor by letter of any discrepancies before proceeding with the work. Failure to do so constitutes acceptance of work by other trades.

Check shop drawings, installation instructions, architectural drawings and shipping lists to become familiar with the project. The shop drawings take precedence and include specific details for the project. The installation instructions are of a general nature and cover the most common conditions. Due to varying job conditions all sealant used must be approved by the sealant manufacturer to ensure it will perform per the conditions shown on the instructions and shop drawings. The sealant must be compatible with all surfaces in which adhesion is required, including other sealant surfaces. Use primers where directed by sealant manufacturer. Properly store sealant at the recommended temperatures and check sealant for remainder of shelf life before using.

## FIELD CONDITIONS

All material to be installed must be plumb, level and true. Aluminum to be placed in direct contact with masonry or incompatible material should be isolated with a heavy coat of zinc chromate, bituminous paint or non-metallic material.

# RELIANCE™-SS CURTAIN WALL INSTALLATION MANUAL

After sealant is set and a representative amount of the wall has been glazed (250 square feet or more), run a water hose test in accordance with AAMA 501.2 specifications to check installation. On large projects the hose test should be repeated during the glazing operation.

## CLEANING MATERIALS

Cement, plaster terrazzo, alkaline and acid-based materials used to clean masonry are very harmful to finishes. Any residue should be removed with water and mild soap immediately or permanent staining will occur. A spot test is recommended before any cleaning agent is used. Refer to the Architectural Finish Guide in the Detail Catalog.

## EXPANSION JOINTS

Expansion joints and perimeter joints shown in these instructions and in the shop drawings are shown at nominal size. Actual dimensions may vary due to perimeter conditions and/or differences in metal temperature between the time of fabrication and the time of installation. For example, a 12-foot unrestrained length of aluminum can expand or contract 3/32" over a temperature change of 50° F. Any movement potential should be accounted for at the time of the installation.

## SUGGESTIONS FOR IMPROVING SYSTEM THERMAL PERFORMANCE

To maintain or improve your wall installation the following items should be considered.

- A. Blinds or drapes prevent warm air from adequately flowing over the window surface.
- B. Warm air ventilators too far from the window will not adequately wash the window with air to prevent condensation.
- C. In extreme conditions the fan of the heating system should not cycle on and off but should run continuously.
- D. Some heating systems have a water injection feature that can raise humidity levels. The higher the humidity levels the more likely condensation or frost will form. Raising the temperature and reducing humidity will usually solve the problem.
- E. On rare occasions an extremely cold storm may cause frost to appear on the glass framing. A space heater and electric fan blowing along the plane of the window wall can reduce or eliminate this temporary condition.

# RELIANCE™-SS CURTAIN WALL INSTALLATION MANUAL

## INSTALLATION TYPES

The following diagrams represent common types of installations for this product. Refer to approved shop drawings for specifics regarding splicing and anchoring of frame.

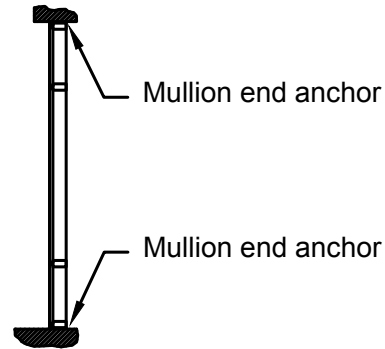
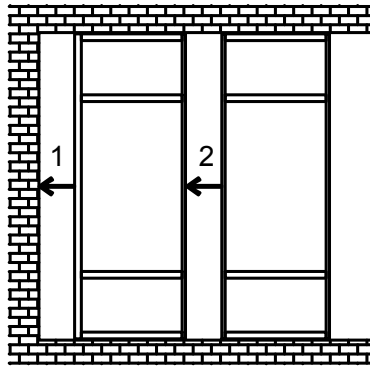

**Single Span**

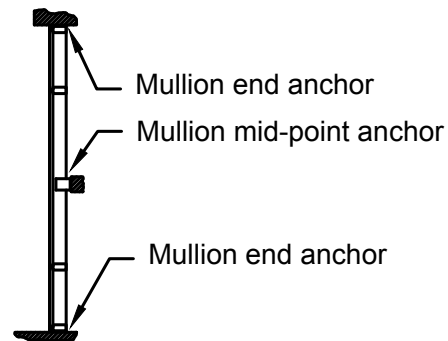
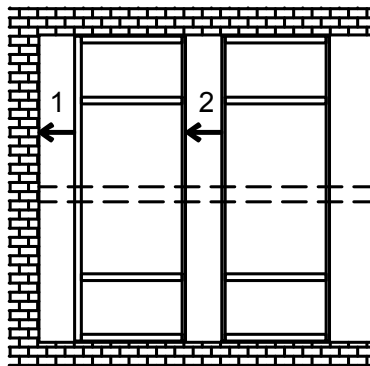

**Twin Span**

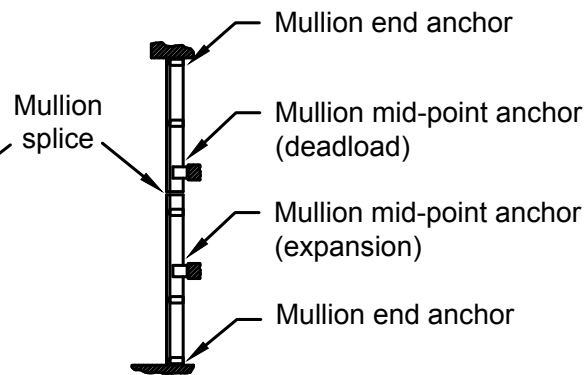
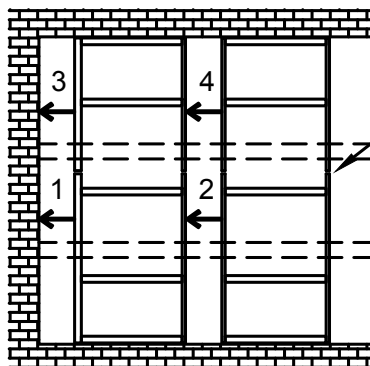

**Multi-Span**

# RELIANCE™-SS CURTAIN WALL INSTALLATION MANUAL

## FRAME FABRICATION

Unless otherwise noted, the details shown in these instructions reflect the 7 1/4" system. Part numbers and dimensions in parentheses ( ) refer to the 6" system, unless noted otherwise. Instructions for other backmember depths are similar. **NOTE:** Structural silicone glazed vertical mullion is referred to as "SSG mullion"

1.1 Measure ROUGH OPENING to determine FRAME WIDTH and FRAME HEIGHT dimensions. Allow 1/2" minimum clearance for shimming and caulking around perimeter of frame.

1.2 Cut material to size. **SEE FIGURE 1, page 8** for guide.

### Frame Members

Verticals	FRAME HEIGHT (ROUGH OPENING minus top & bottom joints)
Vertical Pressure Plates	FRAME HEIGHT minus 1/4"
Vertical Face Covers	FRAME HEIGHT (vertical covers run through)
Intermediate Horizontals	Daylight Opening (D.L.O.)
Head and Sill Members	D.L.O.
Horizontal Pressure Plates	D.L.O. minus 1/4"
Horizontal Face Covers	D.L.O. minus 1/16"
Head & Sill Interior Covers	D.L.O. minus 1/16"

### Accessories

#### Glazing Gaskets

Exterior	Pressure Plate length plus allowance*
Interior at Verticals	D.L.O. plus 1" plus allowance* (vertical gaskets run through)
Interior at Horizontals	D.L.O. plus allowance*
Silicone Spacer Gaskets	D.L.O. plus 1" plus allowance*
Thermal Isolator	Vertical length (crowd in place to avoid gaps at ends) (cut back 3/4" from bottom of vertical mullions)
Vertical Air Seal Gasket	Vertical length

*\*Glazing gaskets should be cut 1/4" longer per foot of aluminum extrusion. Set aside and lay flat until ready to glaze.*

### Other Members (as required)

#### Glazing Adaptors

Horizontal	D.L.O. minus 1/32"
Vertical	D.L.O. plus 1"

*\*See "VERTICAL SPLICING" instructions, page 31, for special instructions on cut lengths and fabrication in these areas.*

#### Door Subframe

Jamb	DOOR OPENING plus 7/8"
Header	DOOR OPENING minus 1/32"

#### Flush Door Pressure Plate

Jamb	DOOR OPENING plus 3/4"
Header	DOOR OPENING minus 1/16"

#### Flush Door Face Cover

Jamb	DOOR OPENING plus 2-1/2"
Header	DOOR OPENING minus 1/16"

### Glass Sizing

#### Field Glazing

Captured Mullions	1/2" glass bite typical (D.L.O. plus 1")
SSG Verticals	1" glass bite at verticals (D.L.O. plus 2") 1/2" glass bite at horizontals (D.L.O. plus 1")

#### Shop Glazing

Captured Mullions	9/16" glass bite typical (D.L.O. plus 1 1/8")
SSG Verticals	1" glass bite at verticals (D.L.O. plus 2") 9/16" glass bite at horizontals (D.L.O. plus 1 1/8")

# RELIANCE™-SS CURTAIN WALL INSTALLATION MANUAL

## FRAME FABRICATION

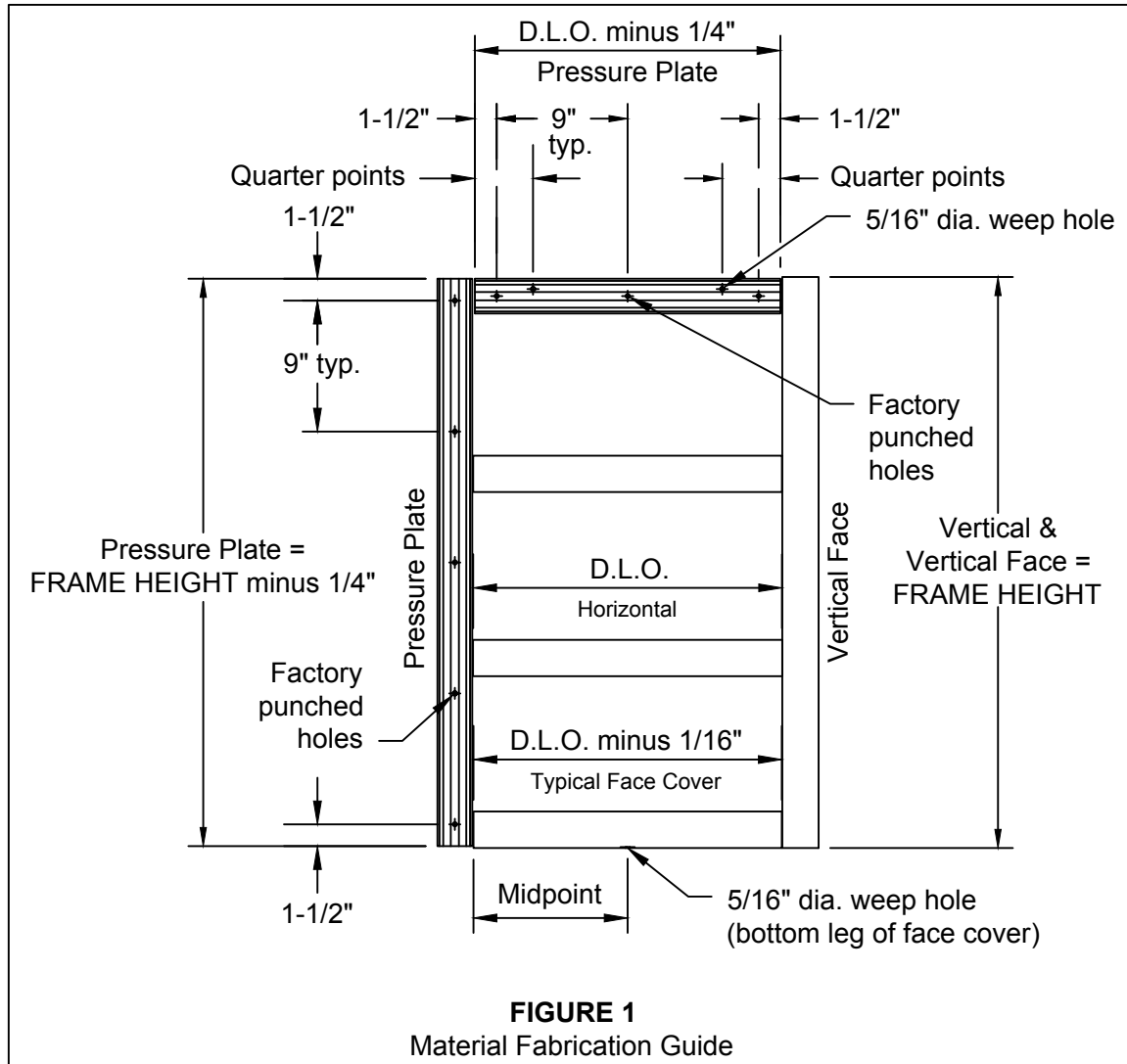

- 1.3 Fabricate vertical mullions for horizontal members with EZ Punch tooling or DJ-105 drill jig. When using the drill jig, drill holes 'A' and 'B' for the 7 1/4" system and 'A' and 'C' for the 6" system. Use 'F' drill (.257 dia.) for assembly screws. Drill all four holes. **SEE FIGURE 2, page 9.** When working from horizontal centerlines, align the slot milled into the drill jig with the centerline. Drill (1) 5/16" diameter weep hole at face of captured mullions, 1/2" from the bottom of each mullion. **SEE FIGURE 3, page 10.**
- 1.4 Install and seal end caps to top and bottom of jamb mullions with (1) FS-320 #10 x 1/2" U-drive screw. **SEE FIGURE 4, page 10.**
- 1.5 Drill 5/16" dia. weep holes at 1/4 points in the horizontal pressure plates. Drill (1) 5/16" dia. weep hole at the bottom of each horizontal face cover at the centerline of the D.L.O. **SEE FIGURE 5, page 10. NOTE: For SSG applications, face covers typically run across SSG mullions, so there will be multiple holes in each horizontal face cover.**
- 1.6 All pressure plates have factory punched holes for screws at 9" O.C. To ensure proper pressure on the glazing, 7/32" dia. holes may need to be drilled at the ends of each horizontal pressure plate as required. Locate holes at 1 1/2" maximum from the ends of the pressure plate.

# RELIANCE™-SS CURTAIN WALL INSTALLATION MANUAL

## FRAME FABRICATION

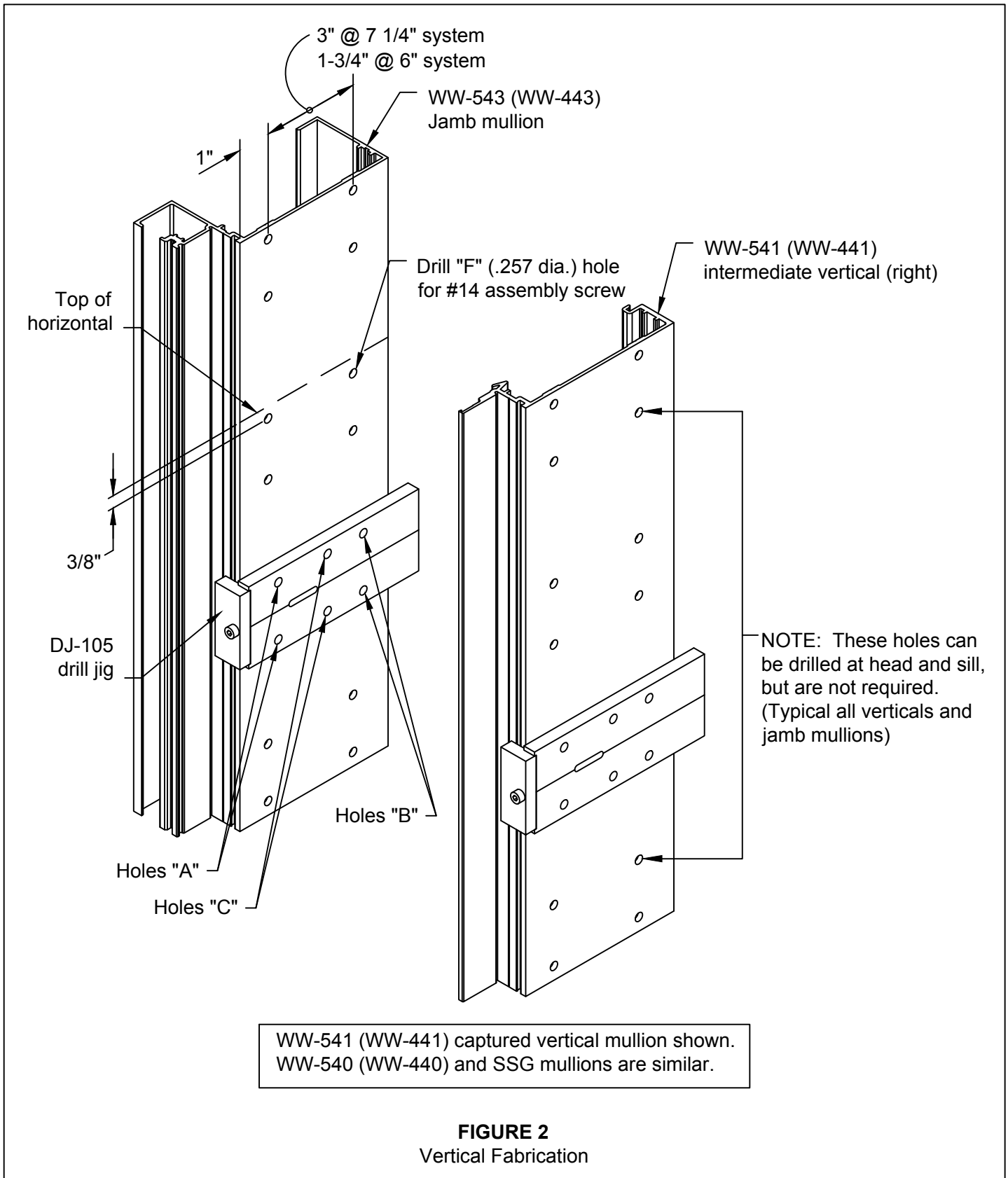

# RELIANCE™-SS CURTAIN WALL INSTALLATION MANUAL

## FRAME FABRICATION

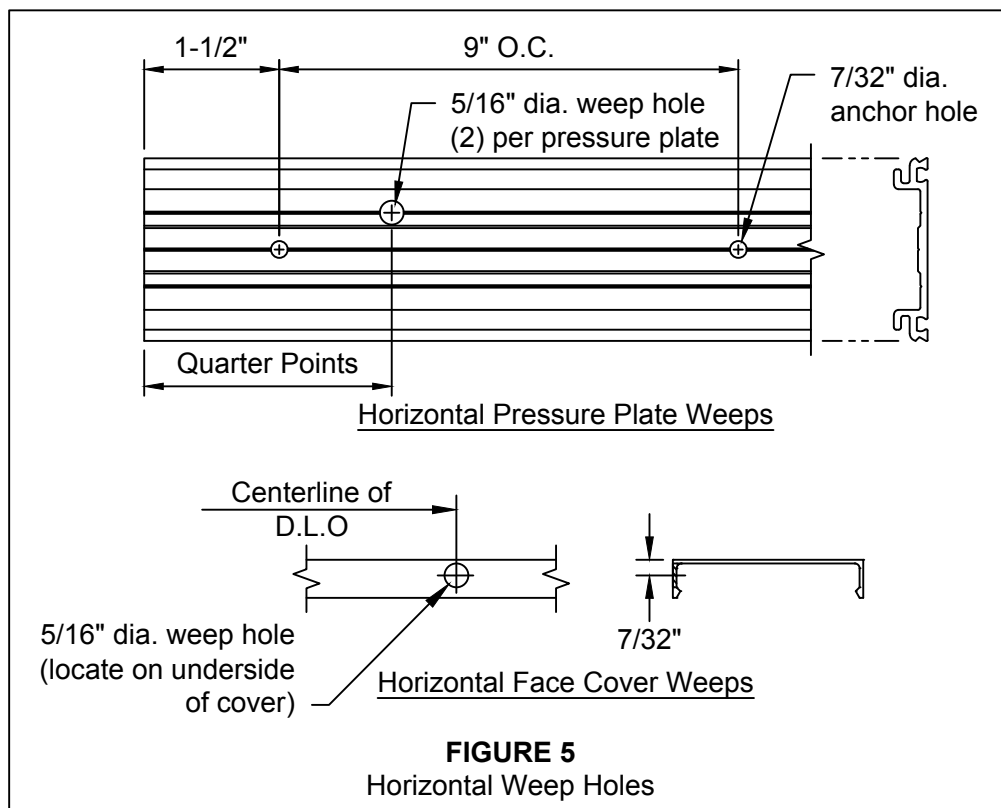
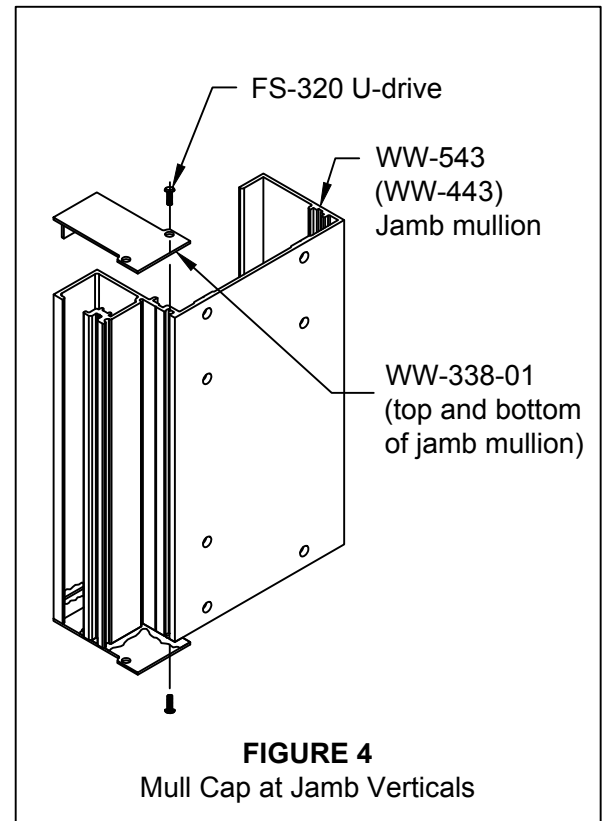
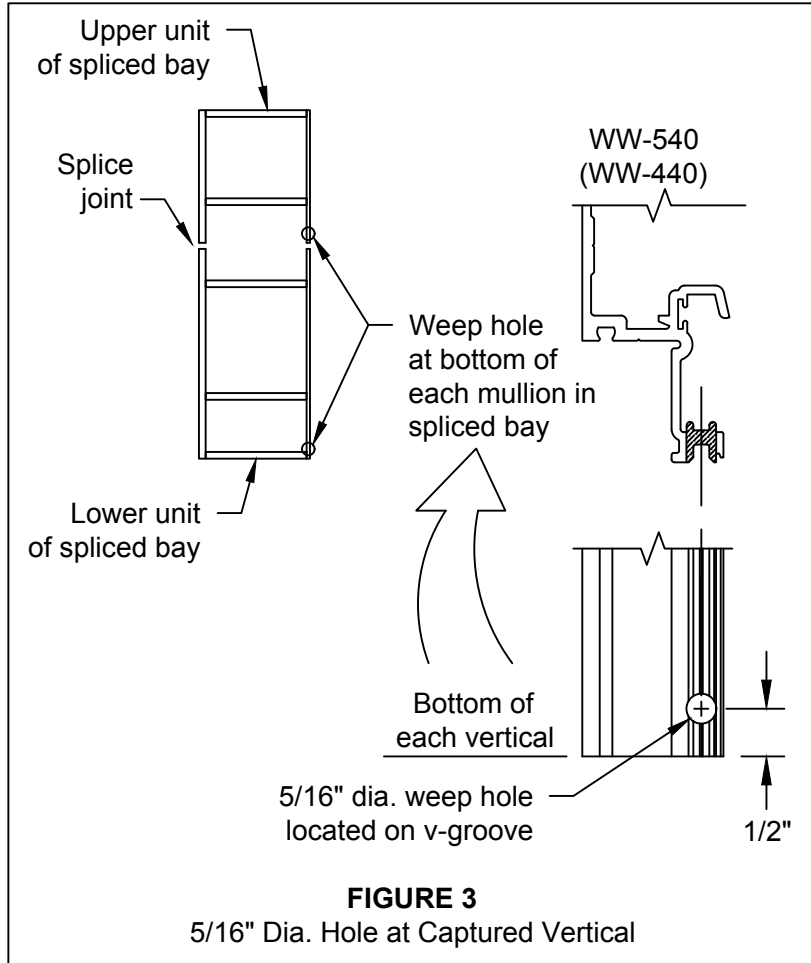

# RELIANCE™-SS CURTAIN WALL INSTALLATION MANUAL

## FRAME FABRICATION

- 1.7 Drill a #29 (.136 dia.) hole at top and bottom in each half of the intermediate vertical mullions for the mullion cap. **SEE FIGURE 6.**

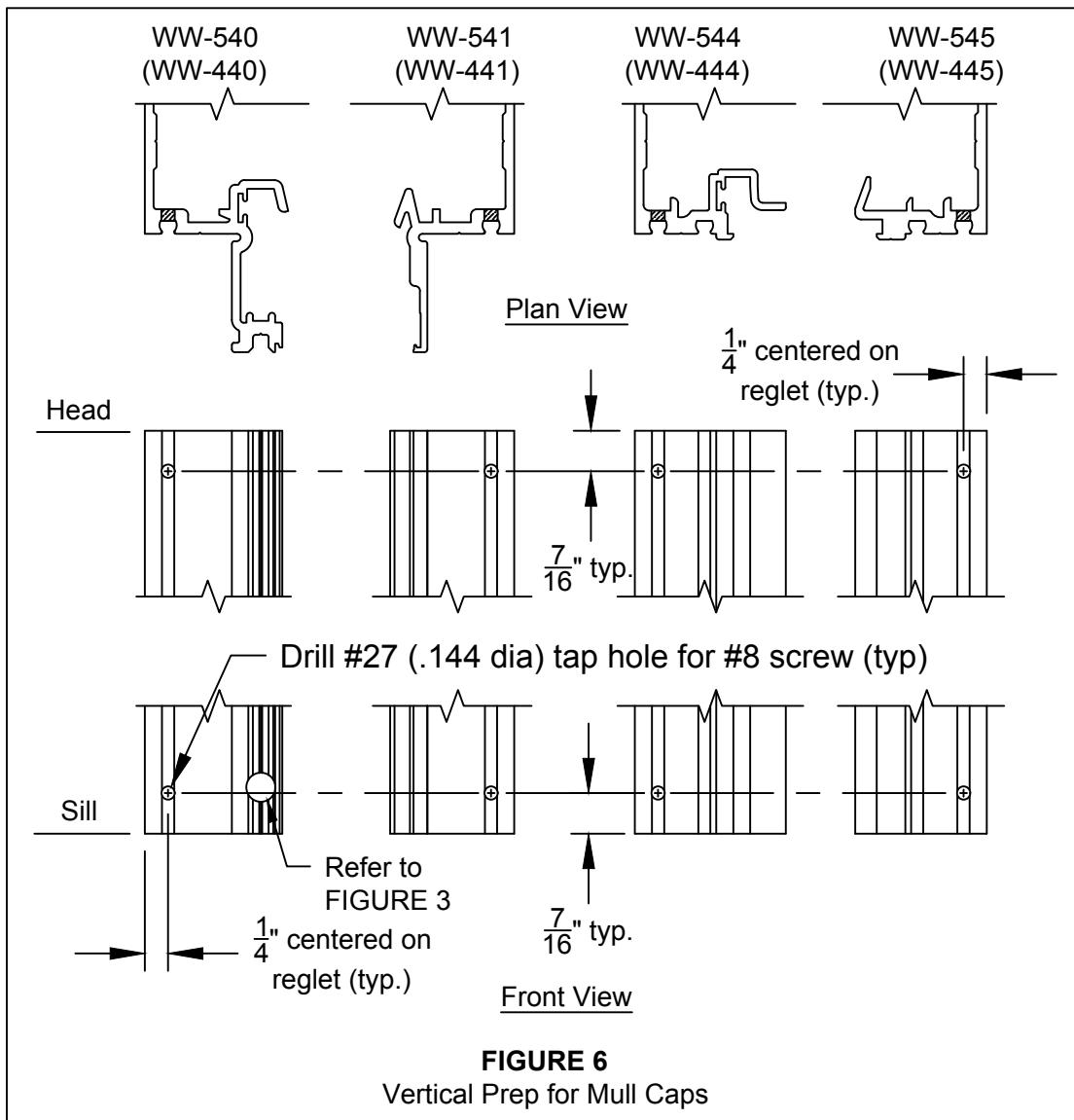

- 1.8 For slide-in mullion anchors, see approved shop drawings for size and location of anchor bolts. Drill access holes in head and/or sill members as required for access to anchors.
- 1.9 For SSG mullions requiring 1/4" glazing adaptors, drill and countersink holes in adaptors at 12" O.C. for a #10 flat head screw. **SEE FIGURE 7.**

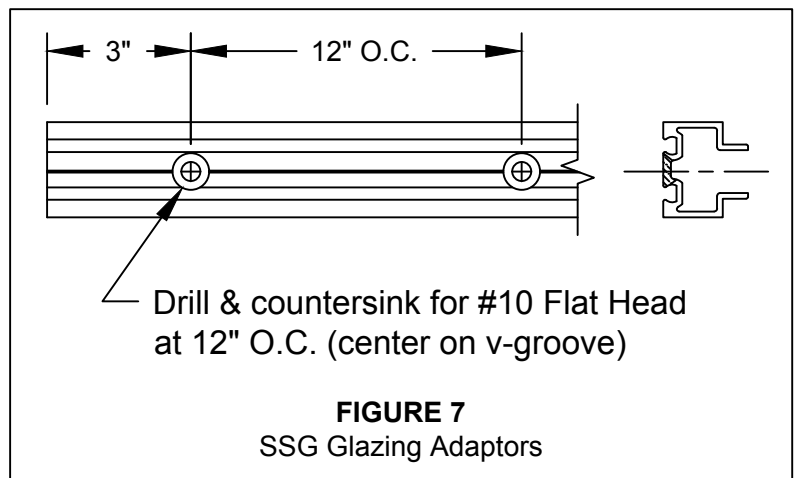

# RELIANCE™-SS CURTAIN WALL INSTALLATION MANUAL

## FRAME ASSEMBLY

- 2.1 Starting with the left jamb of the opening, lay out verticals and horizontals for assembly of the bay. **SEE FIGURE 8.**
- 2.2 Apply sealant to ends of horizontals prior to attaching to verticals. Attach to verticals with FS-8 #14 x 1" Hex Head screw. Three screws are required at each head and sill; four are required at intermediate horizontals. **SEE FIGURE 9, page 13.** Tool excess sealant at horizontal-to-vertical joints.
- 2.3 Install GP-134 bulb gasket into race at center of captured and SSG mullions. Crimp ends of mullion to lock into position. **SEE FIGURE 9, page 13.**
- 2.4 If mullions are spliced, slide splice sleeves into the bottom of the upper bay mullion. Secure with tape. **SEE FIGURE 10, page 13.** Install one (1) FS-322 #14 x 1" TEK screw into the top of the lower bay mullion to act as a stop screw for the splices during frame installation. **SEE FIGURE 11, page 14.**
- 2.5 After bay is assembled, apply sealant to all contact surfaces on vertical and horizontal mullions where the zone plugs will be installed (captured mullions only). Apply sealant to horizontal tongue receptor on zone plug and install at the end of each horizontal, head and sill. Tool any excess sealant around front end of zone plug where thermal isolator abuts the zone plug. Tool sealant in the glazing pockets to ensure a watertight fit. **SEE FIGURE 12, page 15.**

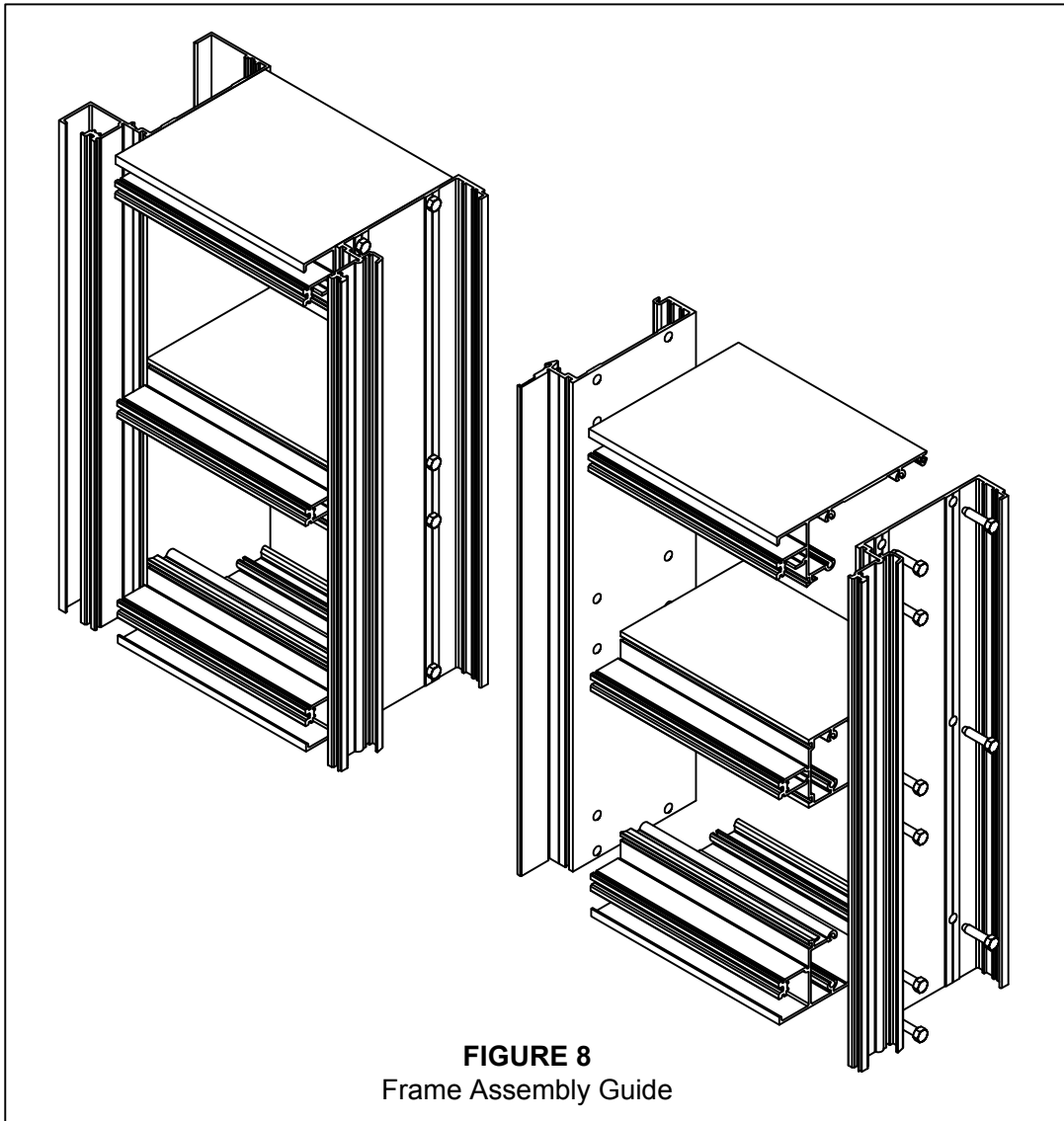

# RELIANCE™-SS CURTAIN WALL INSTALLATION MANUAL

## FRAME ASSEMBLY

Seal both ends of head,  
sill & horizontals prior  
to assembly

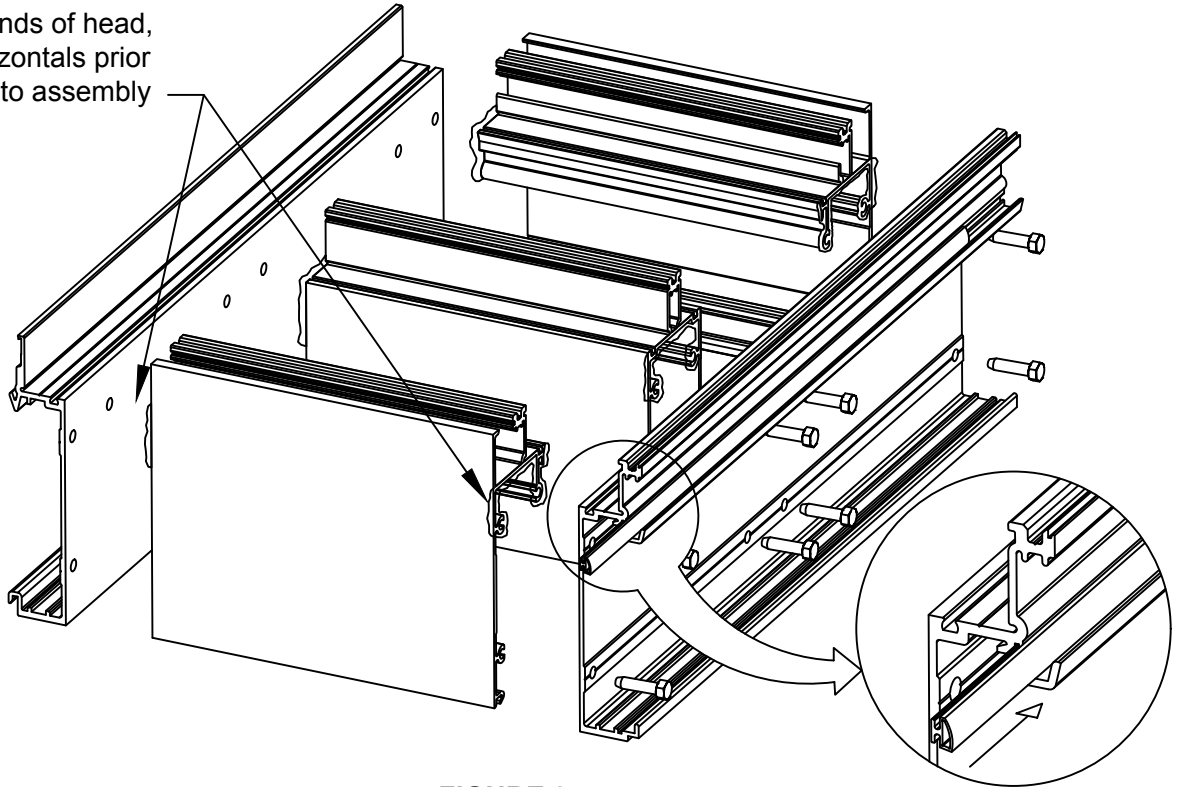

**FIGURE 9**  
Frame Assembly Guide

**GP-134**  
Air Seal Gasket Installation

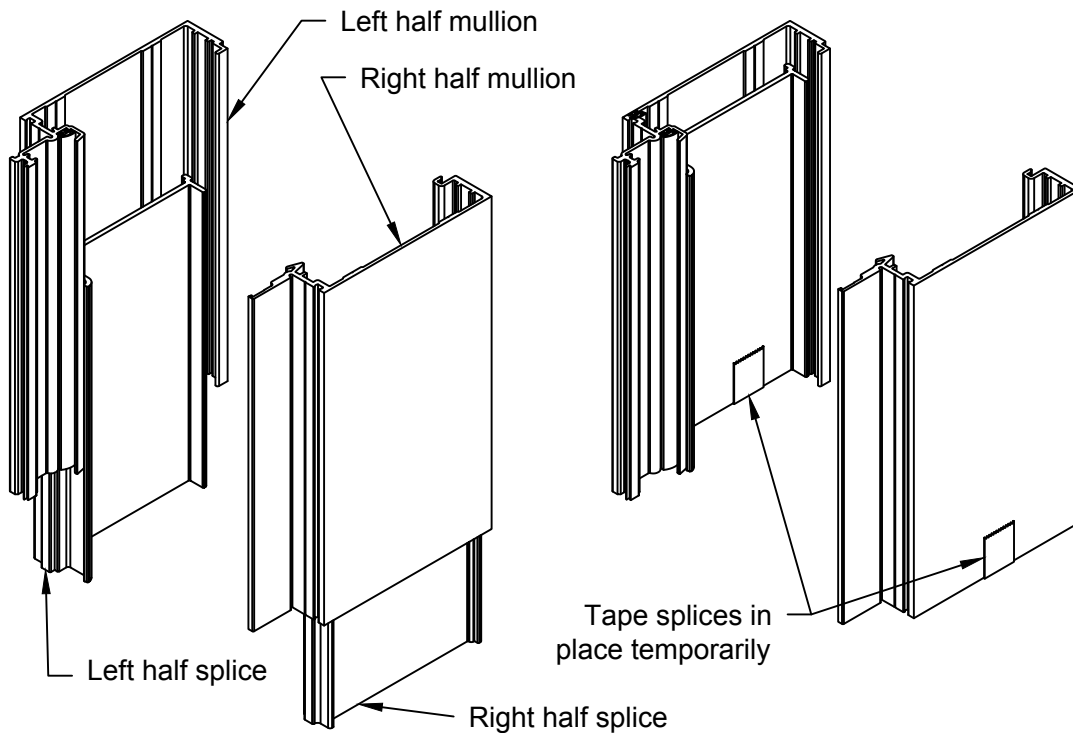

**FIGURE 10**  
Installing Splice in Upper Mullions  
(Captured Shown; SSG Similar)

# RELIANCE™-SS CURTAIN WALL INSTALLATION MANUAL

## FRAME ASSEMBLY

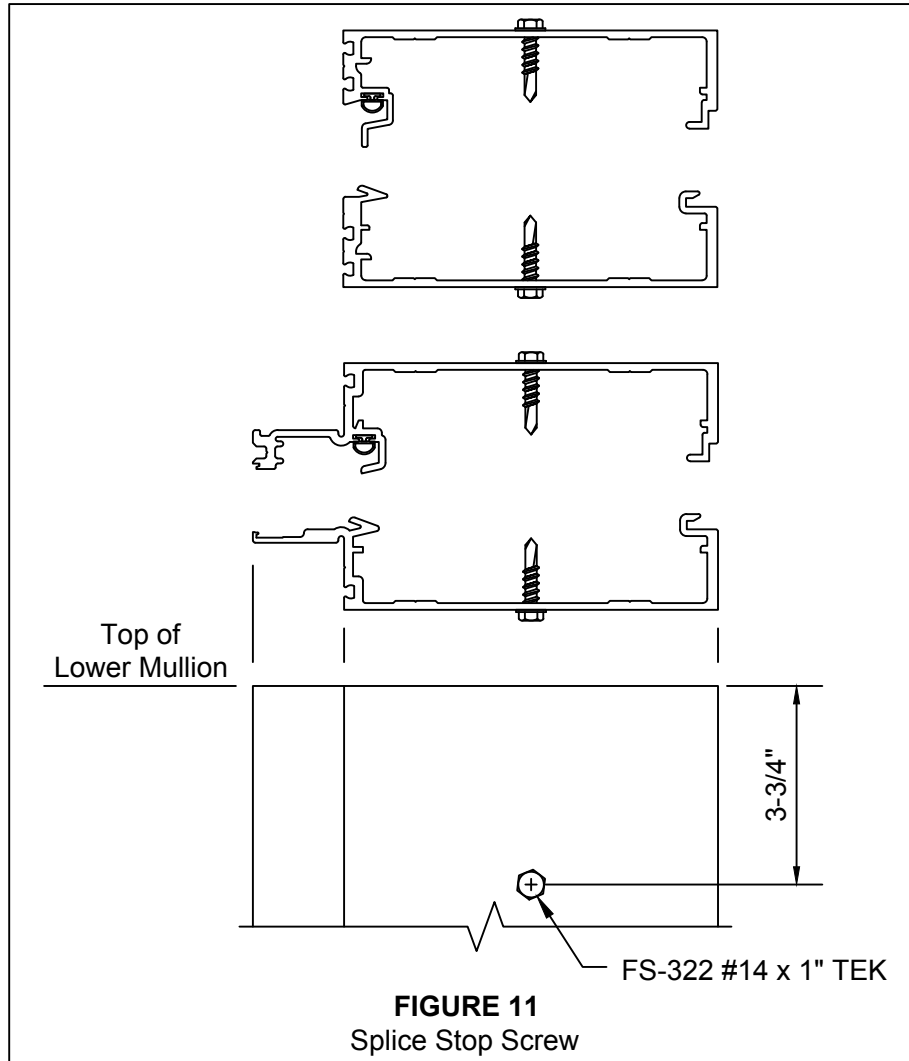

- 2.6 For field glazing, go to step 2.7. If pre-glazing glass, refer to steps 2.8 and 2.9.
- 2.7 Install interior gaskets, running the vertical gaskets through and abutting the horizontal gaskets with a slight bevel. For SSG mullions, install GP-105 spacer gasket on the inner most reglets of the mullion. **DO NOT SEAL GASKETS UNTIL JUST PRIOR TO SETTING GLASS.** Proceed to **FRAME INSTALLATION, page 18.**
- 2.8 If pre-glazing any part of the bay, install the GP-106 interior (frame) gasket in the openings to be pre-glazed. Vertical gaskets run through.

**NOTE: The Reliance-SS system is designed for limited pre-glazing. It is ideal for pre-glazing spandrel lites. Consider weight, staging and handling issues when determining whether pre-glazing is the correct method for a given application.**

- 2.9 To pre-glaze lites, make sure frame is set glass side up, squared and level. Thoroughly clean edges of glass and frame where silicone will be contacting. Seal around edges of glass. **SEE FIGURE 13, page 16** for captured mullions and **FIGURE 14, page 17** for SSG mullions. Tool sealant and set frame aside while silicone cures.
- 2.10 Repeat steps 2.1 to 2.9 until all bays have been assembled.

# RELIANCE™-SS CURTAIN WALL INSTALLATION MANUAL

## FRAME ASSEMBLY

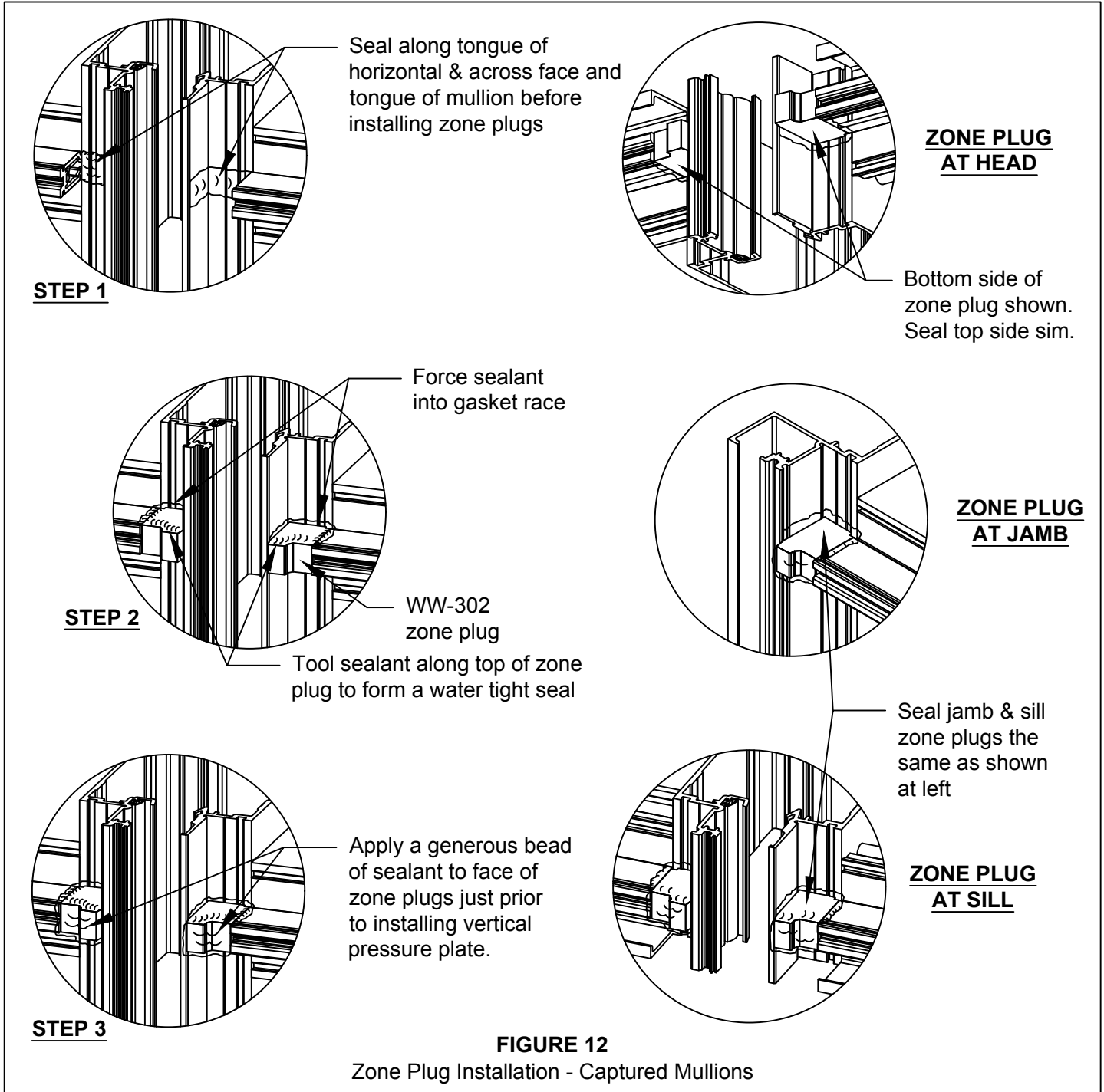

# RELIANCE™-SS CURTAIN WALL INSTALLATION MANUAL

## FRAME ASSEMBLY

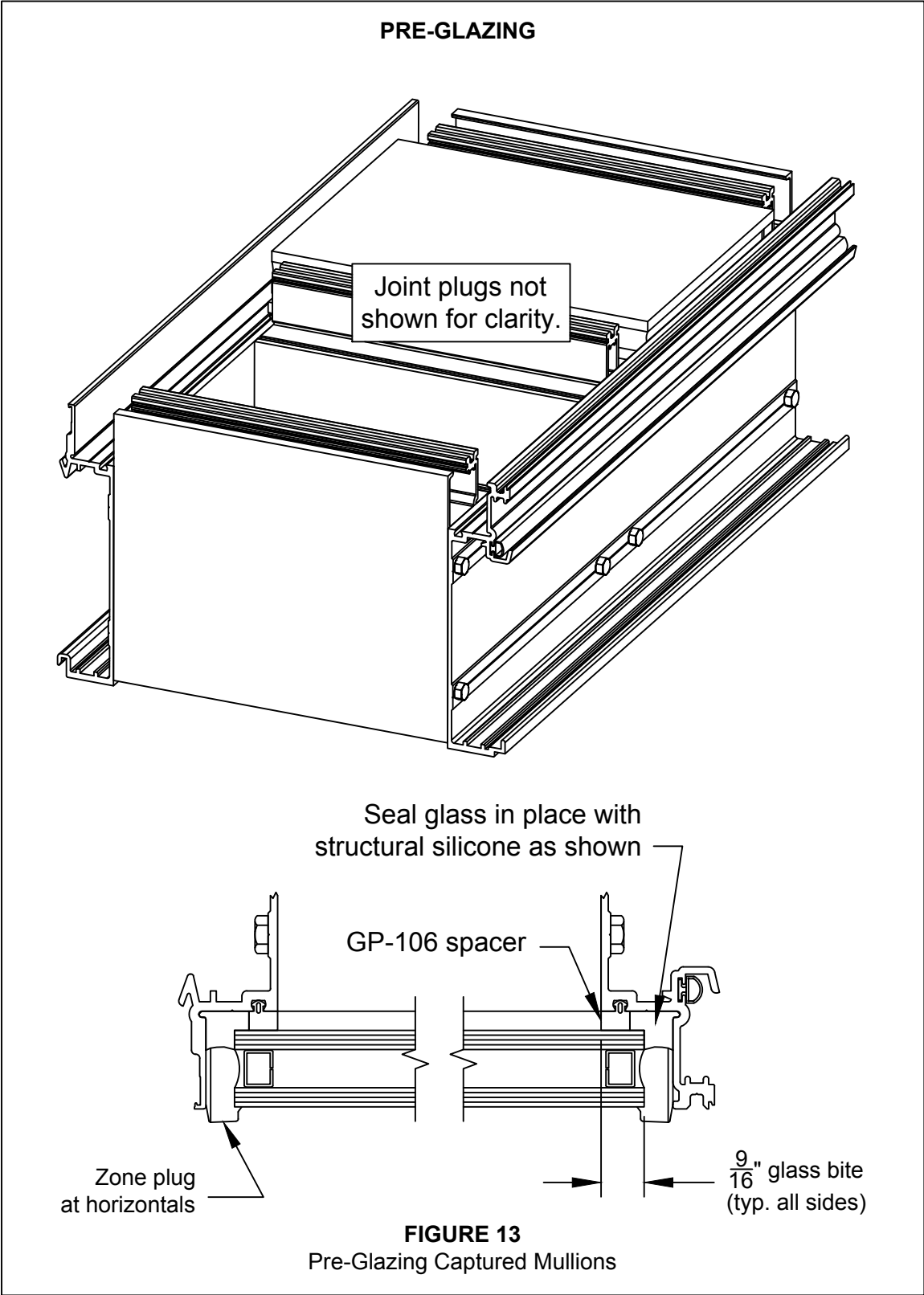

# RELIANCE™-SS CURTAIN WALL INSTALLATION MANUAL

## FRAME ASSEMBLY

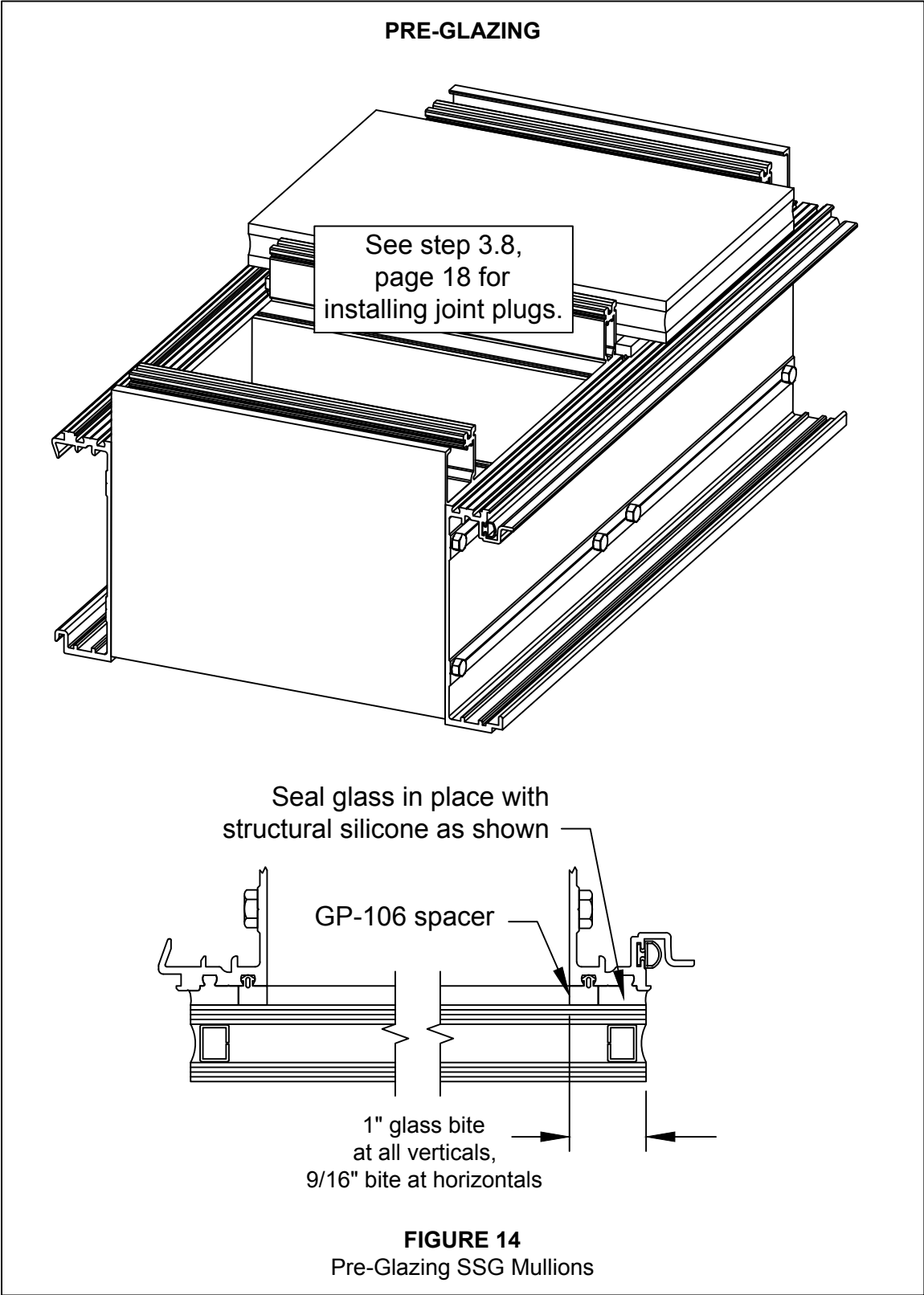

# RELIANCE™-SS CURTAIN WALL INSTALLATION MANUAL

## FRAME INSTALLATION

Anchor type and sizes vary per job requirements. Details shown in these instructions are to be used as a guide only. Refer to approved shop drawings for actual conditions.

3.1 Reliance-SS can be anchored to the building condition by either hard fastening directly through the head/sill member (**FIGURE 15**) or slide-in mullion anchors that fit inside the vertical mullions (**FIGURE 16, page 19**). If using the slide-in anchors, install into ends of mullions prior to erecting the frame.

3.2 Starting with the first bay, install into opening plumb and level. Check perimeter to maintain proper caulk joint. Anchor to structure per approved shop drawings.

3.3 Just prior to setting next bay into opening, seal bulb gasket at sill to 6" above bottom of mullion. NOTE: THIS 6" SEAL IS REQUIRED AT THE SILL AND BOTTOM OF MULLIONS AT SPLICE JOINT. SEE **FIGURE 17, page 20**.

3.4 Set next bay into opening by engaging mullion halves together. Ensure that bottom of mullion halves align. Anchor this bay to structure. For SSG mullions, pin halves together at centerline of horizontals and centerline of D.L.O. with FS-56 #10 x 1/2" Phillips Flat Head screw (or as noted by approved shop drawings). Seal heads of screws. SEE **FIGURE 18, page 20**.

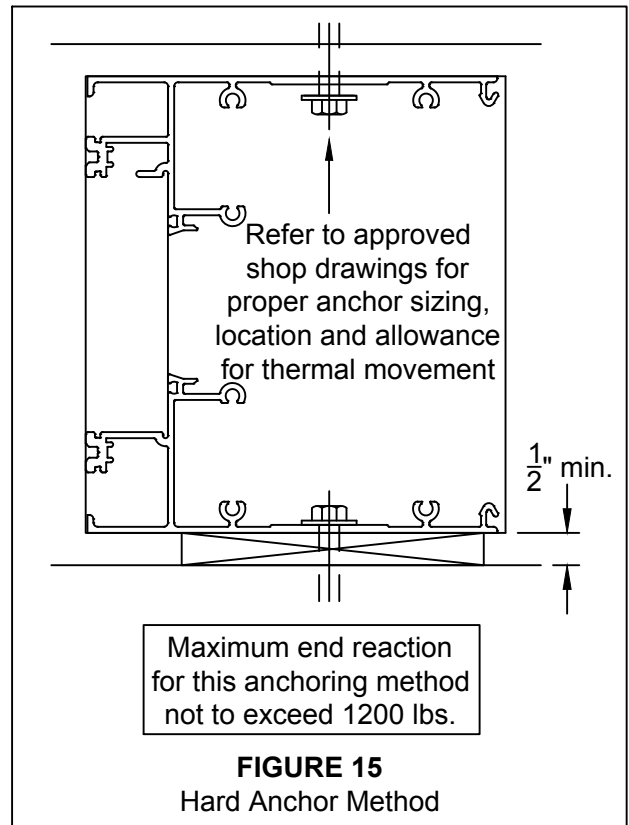

3.5 Temporarily set captured mullions together using WW-333-01 retainer. Locate at 6" from sill, mid-lite and 6" above each splice location. SEE **FIGURE 19, page 21**.

3.6 Repeat steps 3.3 through 3.5 until all bays are installed. Check D.L.O. and diagonal dimensions every four bays to ensure correct spacing and frame squareness to prevent dimensional buildup.

3.7 If mullions are spliced, release splice sleeves from upper mullions and allow to fall onto the set screws at the lower mullions. Attach to lower mullions with (2) FS-322 #14 x 1" TEK screws. Refer to "VERTICAL SPLICING" section, page 31, for sealing instructions.

3.8 At SSG mullions, apply sealant to all contact surfaces on vertical and horizontal mullions where zone bridges will be installed. Apply sealant to horizontal tongue receptor on zone bridge and install at the end of each horizontal, head and sill members. Tool any excess sealant around front end of zone bridge where the thermal isolator runs through. Tool sealant in the glazing pockets to ensure a watertight fit. SEE **FIGURE 20, page 21**.

3.9 Prior to installing mullion caps at top and bottom of all intermediate verticals, seal end caps thoroughly. Install onto mullion with (2) FS-202 #8 x 1/2" Phillips Pan Head screw. SEE **FIGURE 21, page 22**. Tool sealant and cap seal all screws. **THIS IS A CRITICAL SYSTEM SEAL**. Use care when installing mullion end caps to ensure that the bulb gasket seal (step 3.3) is married with the end cap seal.

3.10 When all framing members are installed, apply the perimeter seal. SEE **FIGURE 22, page 22**. The interior perimeter seal is not required for system performance, but may be required for cosmetic purposes. **Perimeter sealing must be completed prior to glazing.**

# RELIANCE™-SS CURTAIN WALL INSTALLATION MANUAL

## FRAME INSTALLATION

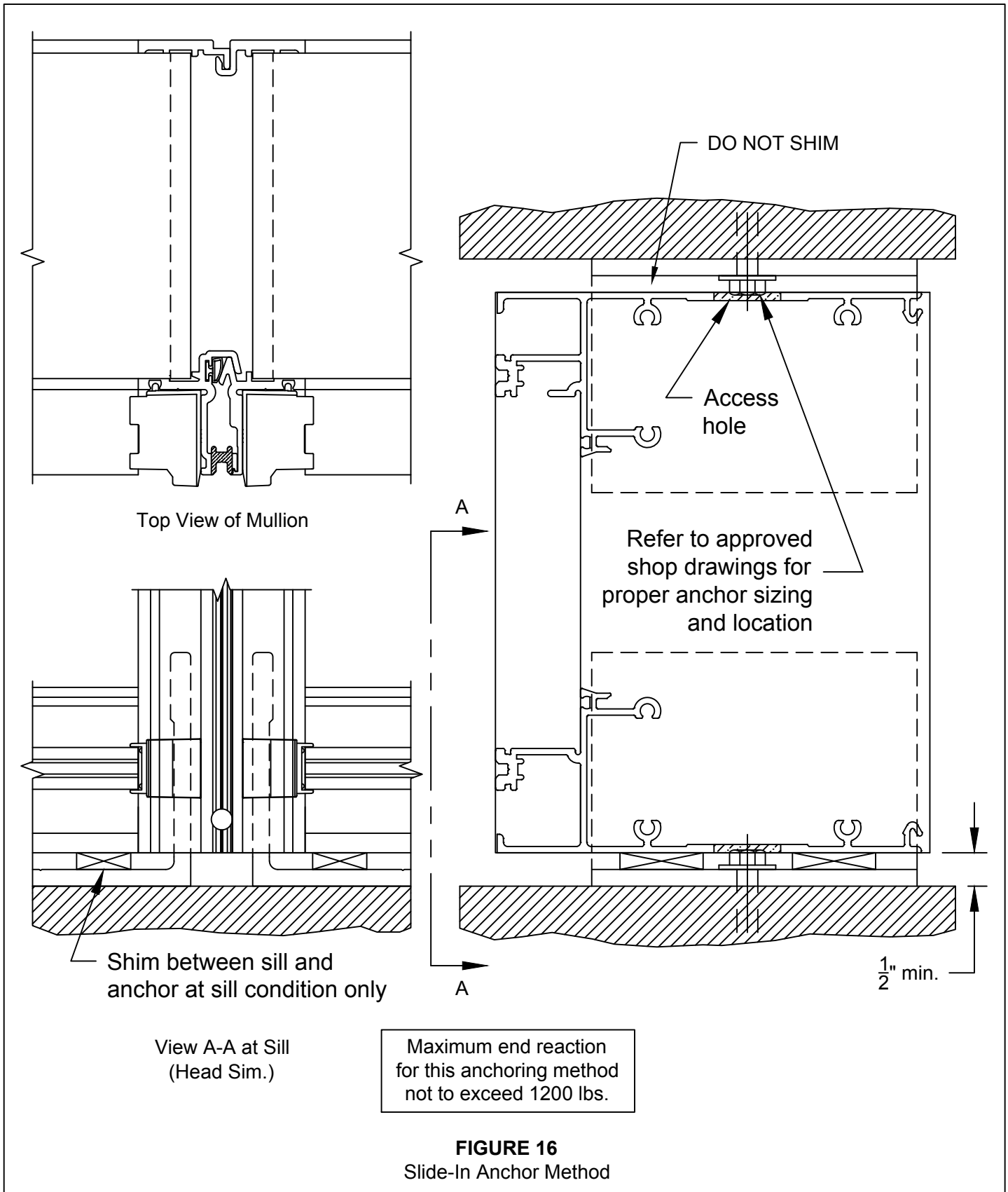

# RELIANCE™-SS CURTAIN WALL INSTALLATION MANUAL

## FRAME INSTALLATION

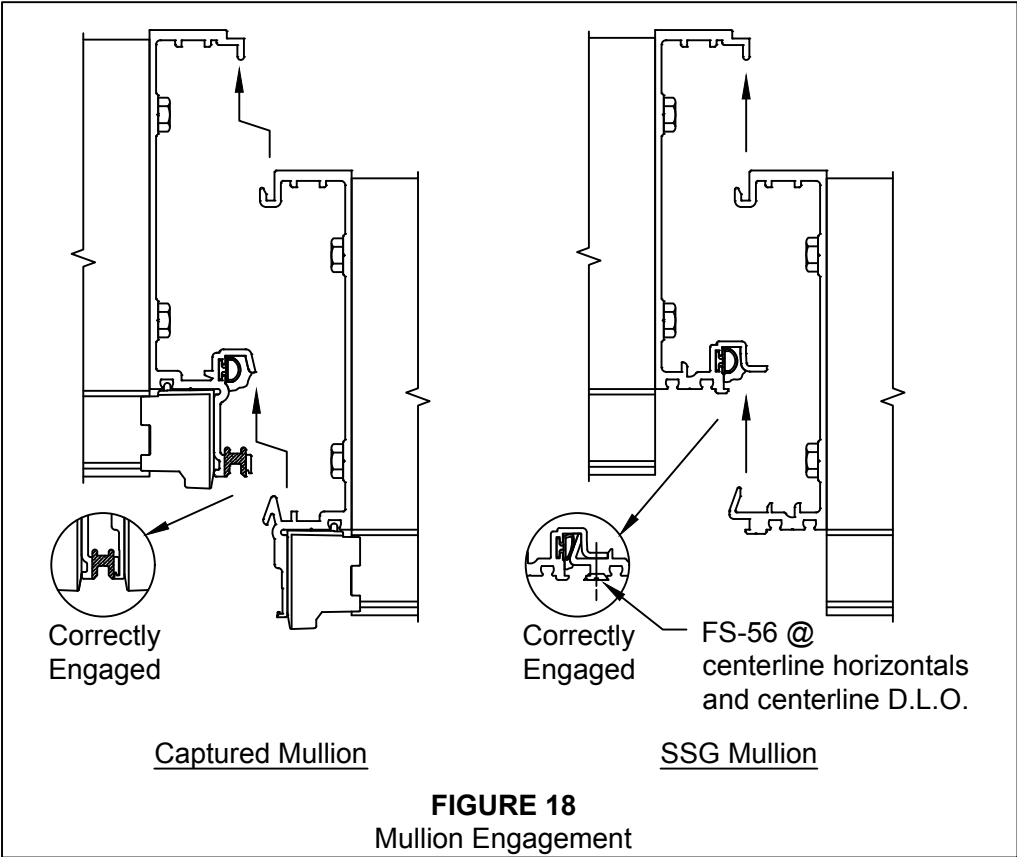
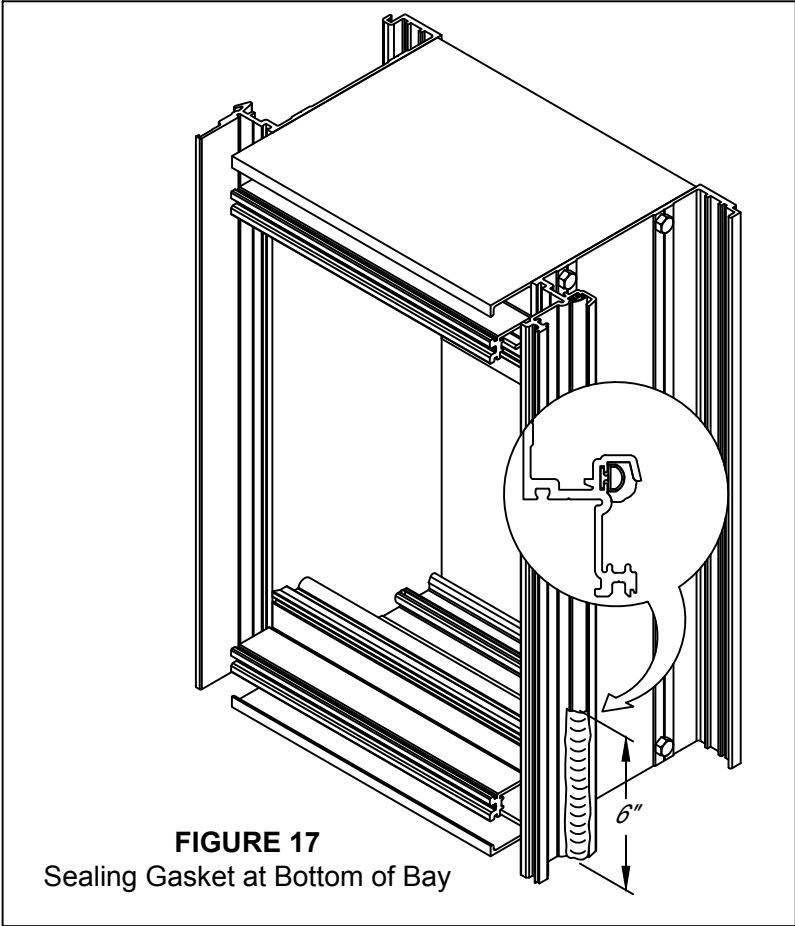

# RELIANCE™-SS CURTAIN WALL INSTALLATION MANUAL

## FRAME INSTALLATION

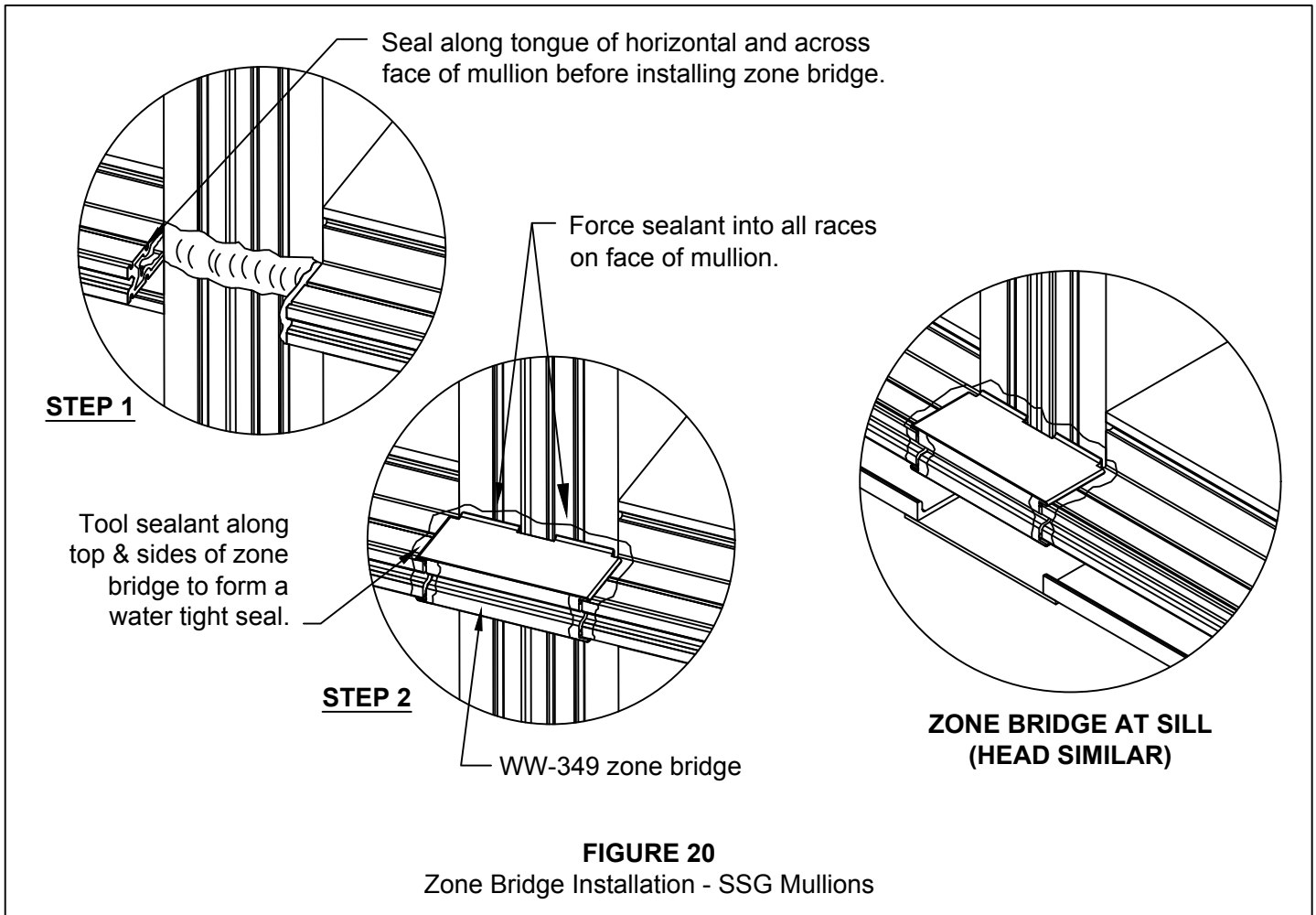
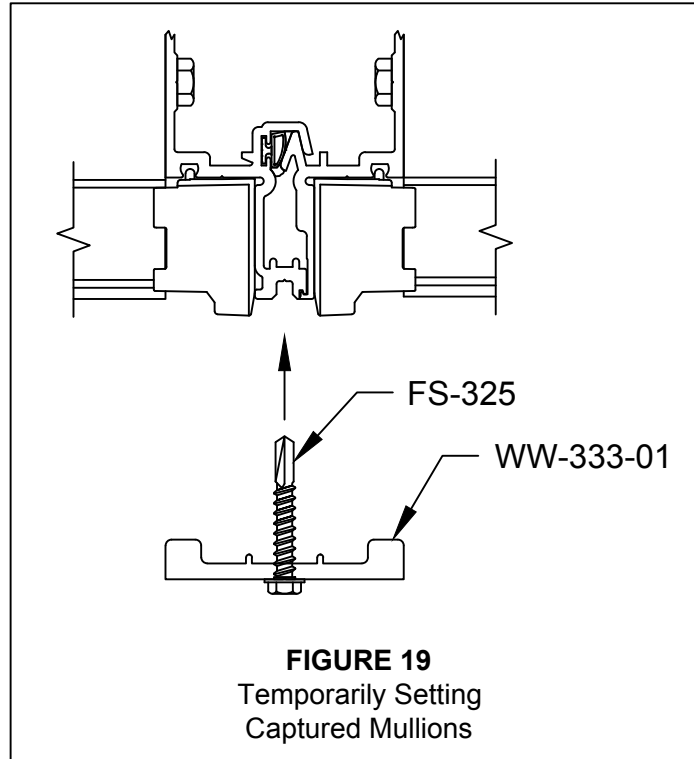

# RELIANCE™-SS CURTAIN WALL INSTALLATION MANUAL

## FRAME INSTALLATION

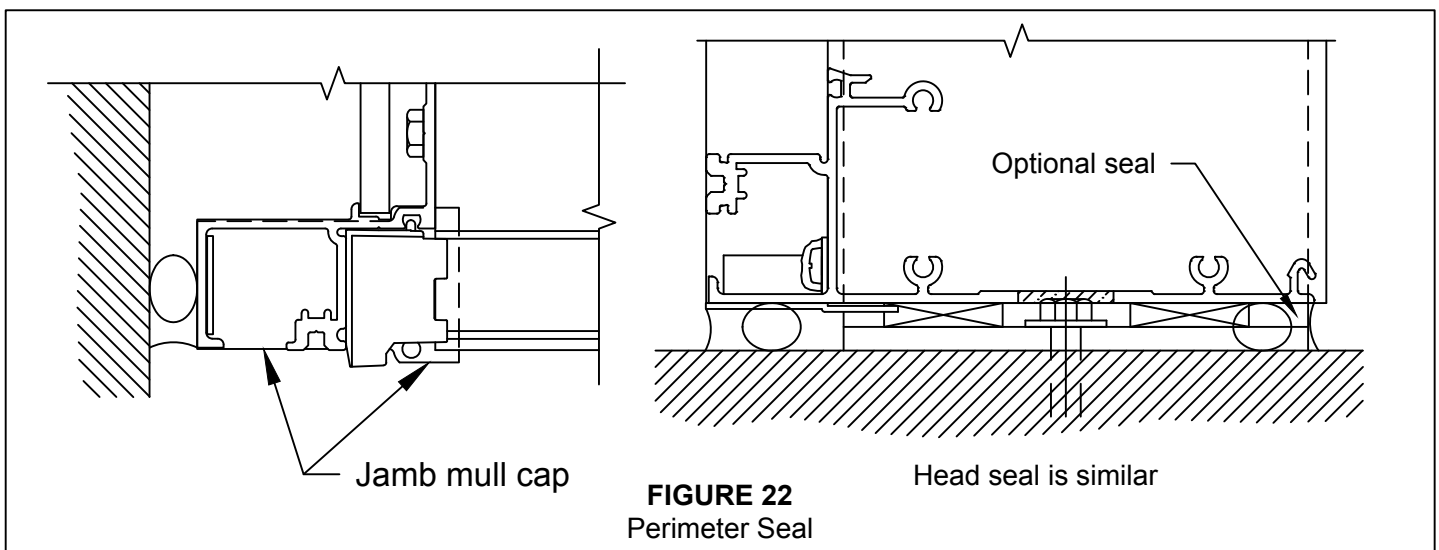
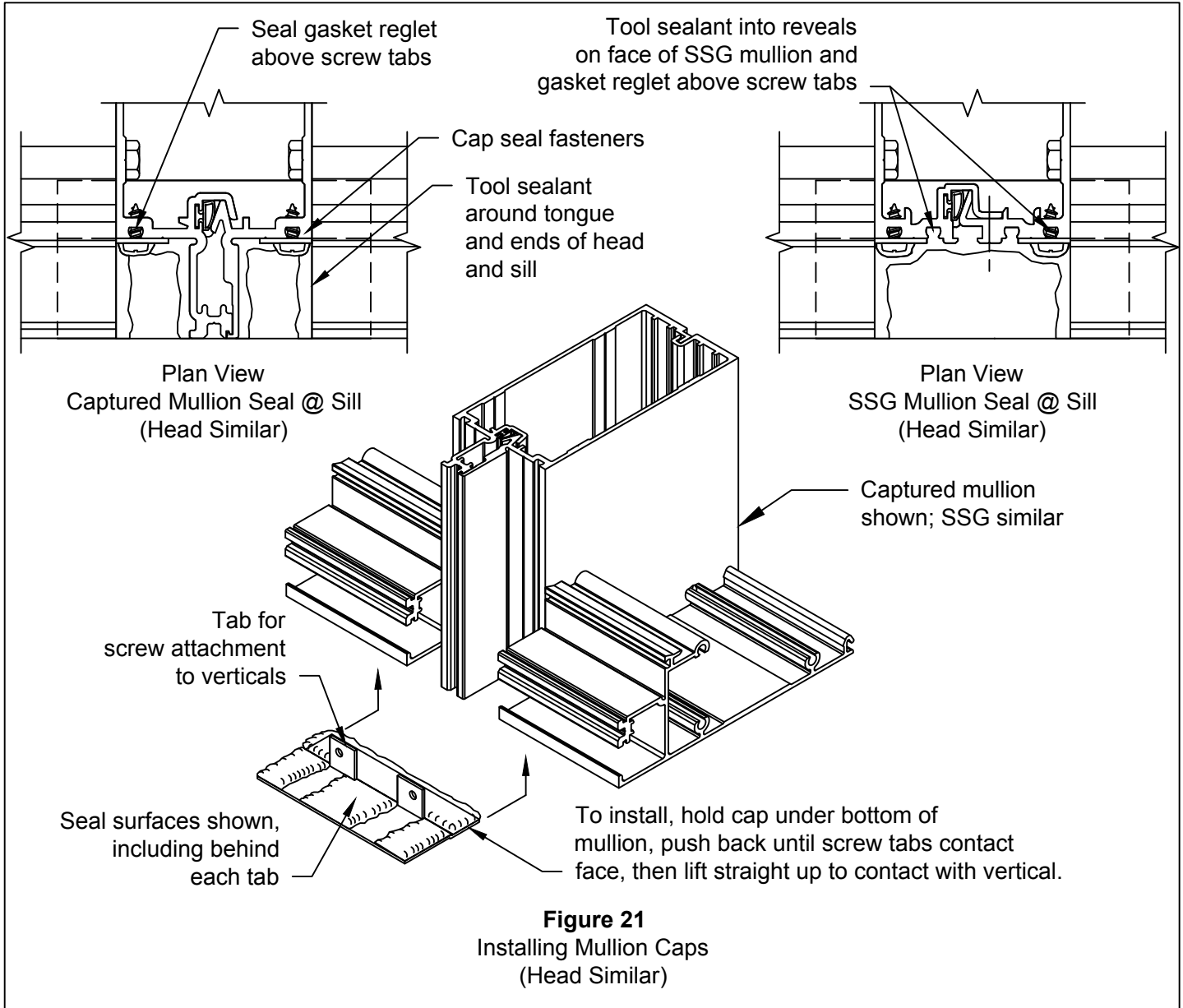

# RELIANCE™-SS CURTAIN WALL INSTALLATION MANUAL

## GLAZING

Start glazing the frame at the bottom and work up. **SEE FIGURE 23** for glass size calculations at corner mullions. Refer to "VERTICAL SPLICING" section prior to glazing if mullions are spliced.

**Note:** Steps 4.1 through 4.16 refer to field glazing of standard 1" infill. For openings requiring transition glazing with adaptors, refer to "TRANSITION GLAZING", page 28.

4.1 Install face gaskets into all pressure plates. Crowd gaskets into pressure plates to avoid gaps caused by relaxation of gasket material. Gaskets should extend about 1/8" beyond end of pressure plates. If not done so already, install frame gaskets in mullions. See step 2.7, page 14.

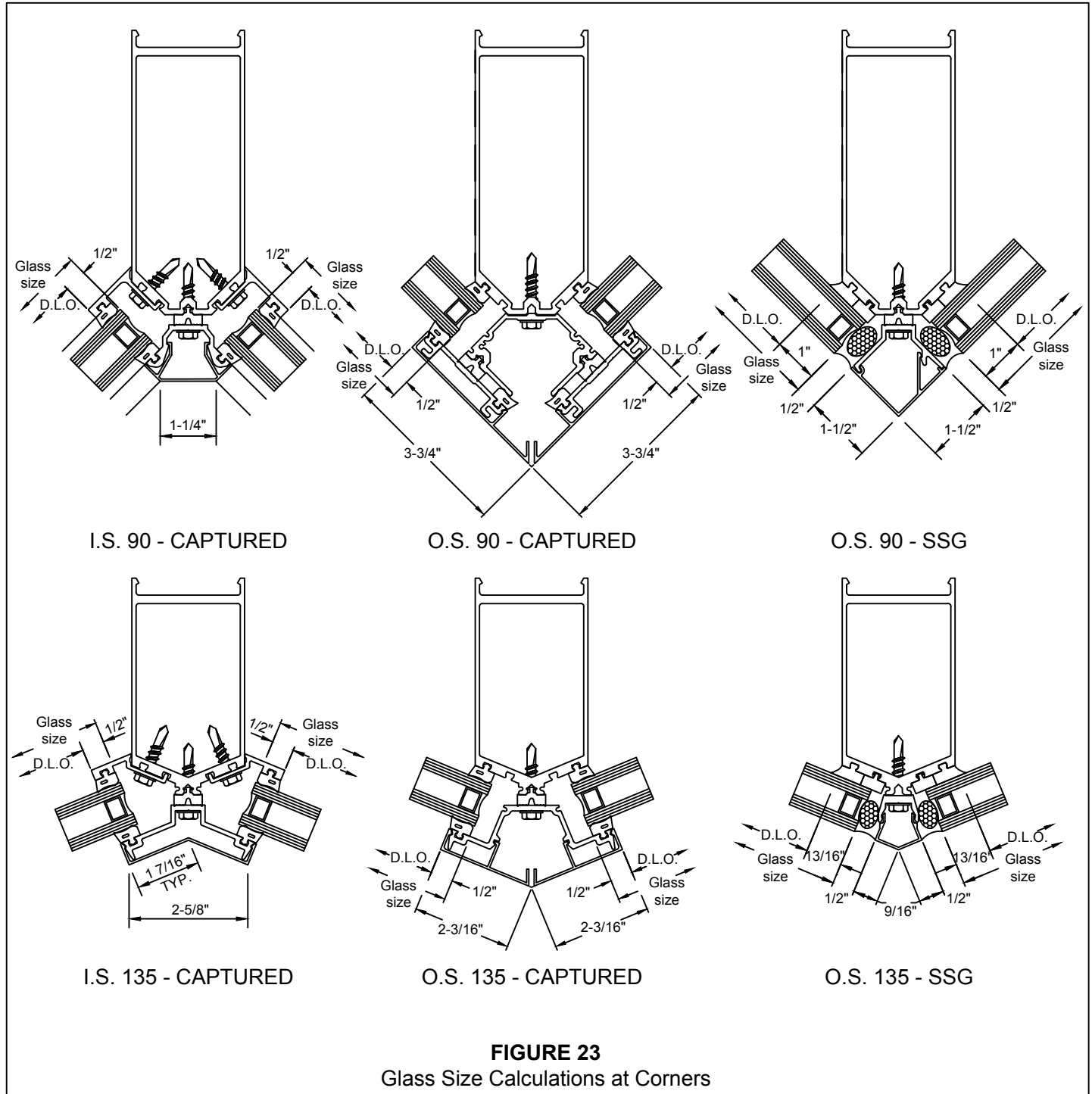

# RELIANCE™-SS CURTAIN WALL INSTALLATION MANUAL

## GLAZING

- 4.2 Install GP-107 thermal isolator into groove on face of mullion tongues. Run through at vertical splice joints. Cut short 1/8" from the head and sill and cut around the 5/16" weep hole at the bottom of each mullion section. **SEE FIGURE 24. NOTE: Mullion splices must be sealed before installing GP-107 isolator. Refer to page 29 for instructions.**

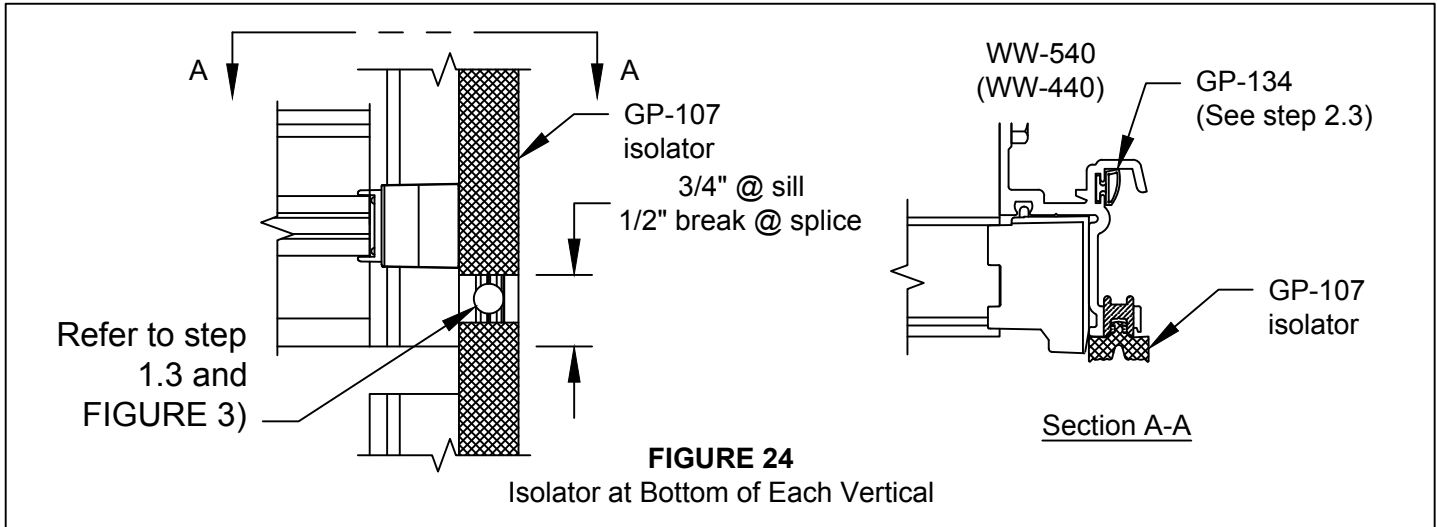

- 4.3 **Note: To avoid silicone curing before glass is set in place and contamination from job-site debris, glazing prep work must be done as each opening is glazed. Do not pre-seal the gaskets in the entire frame; seal only the gaskets in the opening for which you are ready to set glass.**
- For mullions that are spliced, run interior (frame) gasket through the splice joint. Trim the gasket dart as required to form an air tight seal. If mullion splice seal is cured, set gasket in fresh silicone.
  - Crowd gaskets into corners, cutting horizontal gaskets at a slight angle to conform to the bevel on vertical gaskets.
  - Pulling the horizontal gasket back at the ends, seal joint at gasket corners **JUST PRIOR TO GLAZING THE OPENING**. Release the gasket back to its original position, making sure sealant fills the entire joint.
  - Tool corner joints after glass is set and temporary glazing retainers are in place.

**NOTE: Sealant is not required at the horizontal gasket abutting and SSG mullion. This gap will be sealed during application of the structural silicone.**

- 4.4 Position setting blocks at correct locations (two per lite). Refer to approved shop drawings or deadload charts. Lubricating the top of the setting blocks will help ensure proper setting of glass. **Note: Consult glass manufacturer for correct setting block location and length for glass sizes in excess of 40 sq.ft.**
- 4.5 Set glass in opening. Ensure that glass bite is equal on all sides. **CAUTION: Be certain that glass is placed firmly against interior gasket to ensure a proper seal and to avoid binding the glass on the setting block.**
- 4.6 Temporarily hold glass in the opening with WW-333-01 temporary glazing retainers and FS-325 screw. Torque screws to 60 in-lbs. Use the SPW-PP-3 retainer for SSG verticals.
- WW-333-01 temporary glazing retainers must be applied at each glass edge 3" from the corner of the glass. Glass edges greater than 4' in length but less than 8' require an additional retainer at the glass mid-span.
  - Retainers are intended for short term use only. Additional retainers may be required to withstand full design wind load pressures.
  - Full length pressure plates must be installed if severe weather or high wind loads are anticipated. **SEE FIGURES 25 & 26, page 25.**

# RELIANCE™-SS CURTAIN WALL INSTALLATION MANUAL

## FACE CAP INSTALLATION

### Vertical Face Covers:

The use of safety fasteners to mechanically fasten exterior face covers is required for all vertical covers which run through at the head and sill, and all covers, both vertical and horizontal with a depth greater than 3/4". Spacing of the safety fastener is dependent on cover depth, wind load, and snow and ice load conditions. For a standard depth vertical cover up to 14'-0" in length, a single fastener on one side of the cover should be sufficient. Location of the fastener in the center of the length is preferable, but not absolute. For aesthetics, it may be desirable to locate the fastener at a horizontal, so fastener is concealed underneath the horizontal face cover. For vertical covers which are 4" or greater in depth, two fasteners, one on each side of the cover, opposing each other, are required. Again, location of the fasteners in the center of the length is preferred but not absolute. For vertical covers which are 8" or greater in depth, multiple fasteners, placed on each side of the cover opposing each other, may be required. Harmonics caused by wind vibration must be considered, as well as lateral wind load on the cover itself, wind load deflection of the mullion and cover, and snow and ice load.

### Horizontal Face Covers:

For a horizontal cover up to 8'-0" in length and up to 4" deep, a single fastener located at the center of the length on the top side of the cover should be sufficient. Location of the horizontal fasteners on the top side is the best practice. For horizontal covers greater than 8'-0" or deeper than 4", multiple fasteners may be required. Harmonics caused by wind vibration must be considered, as well as wind load deflection of the horizontal and cover, and snow and ice load.

See **FIGURE 24** below for three common pressure plate and face cap installations, other custom profiles may be used and attached following this method. Type 1 may be used up to 4" in depth. Type 2 and 3 are for caps 4" or greater, with type 3 being preferred for any cap or cap assembly greater than 8". All caps shown below will be attached using a (FS-317)1/8" x 3/4" S.S. Headed Roll Pin. Drill cap with a 1/8" (.125") clearance hole.

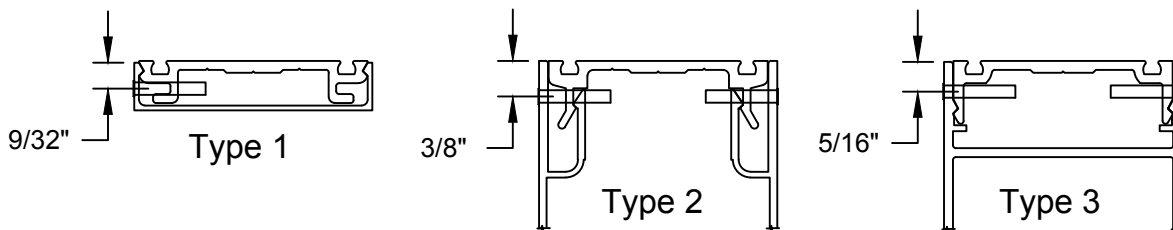

Face Cover Fabrication

# RELIANCE™-SS CURTAIN WALL INSTALLATION MANUAL

## GLAZING

- 4.7 If required, install GP-111 (1" glass) or GP-112 (1/4" spandrel) side blocks with silicone at centerline of each lite, along vertical edges, or per approved shop drawings. For framing that will be subjected to seismic events, consult glass manufacturer for preferred location. **NOTE: Side blocks are not required at SSG mullions.**
- 4.8 Repeat steps 4.3 through 4.7 until all glass is set, working row by row up the elevation.
- 4.9 Just prior to installing vertical pressure plates, apply sealant to face of each horizontal zone plug. **SEE FIGURE 27, page 25.** Vertical pressure plates must be installed before horizontal pressure plates are applied. **FS-325 pressure plate screws must be located 1 1/2" from horizontal & vertical mullion intersections in order to maintain proper compression on the glass. Drill additional 7/32" holes in pressure plates as required.**

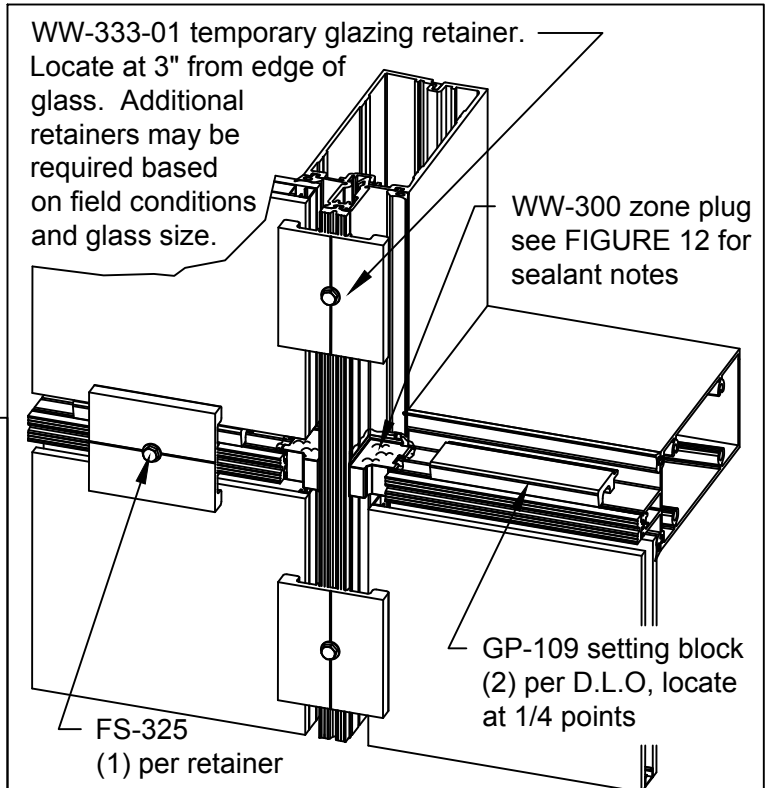

**FIGURE 26**  
Temporary Glazing Instructions

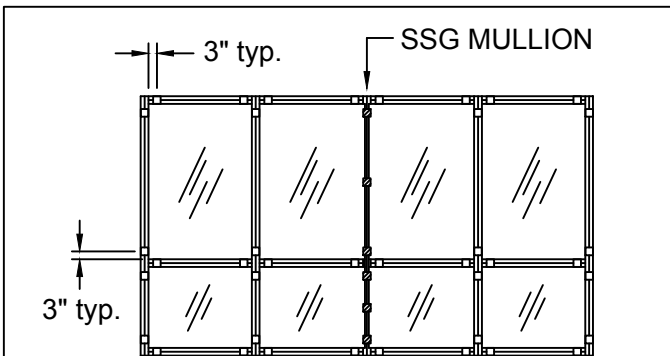

**FIGURE 25**  
Typical Location of Temporary Glazing Retainers

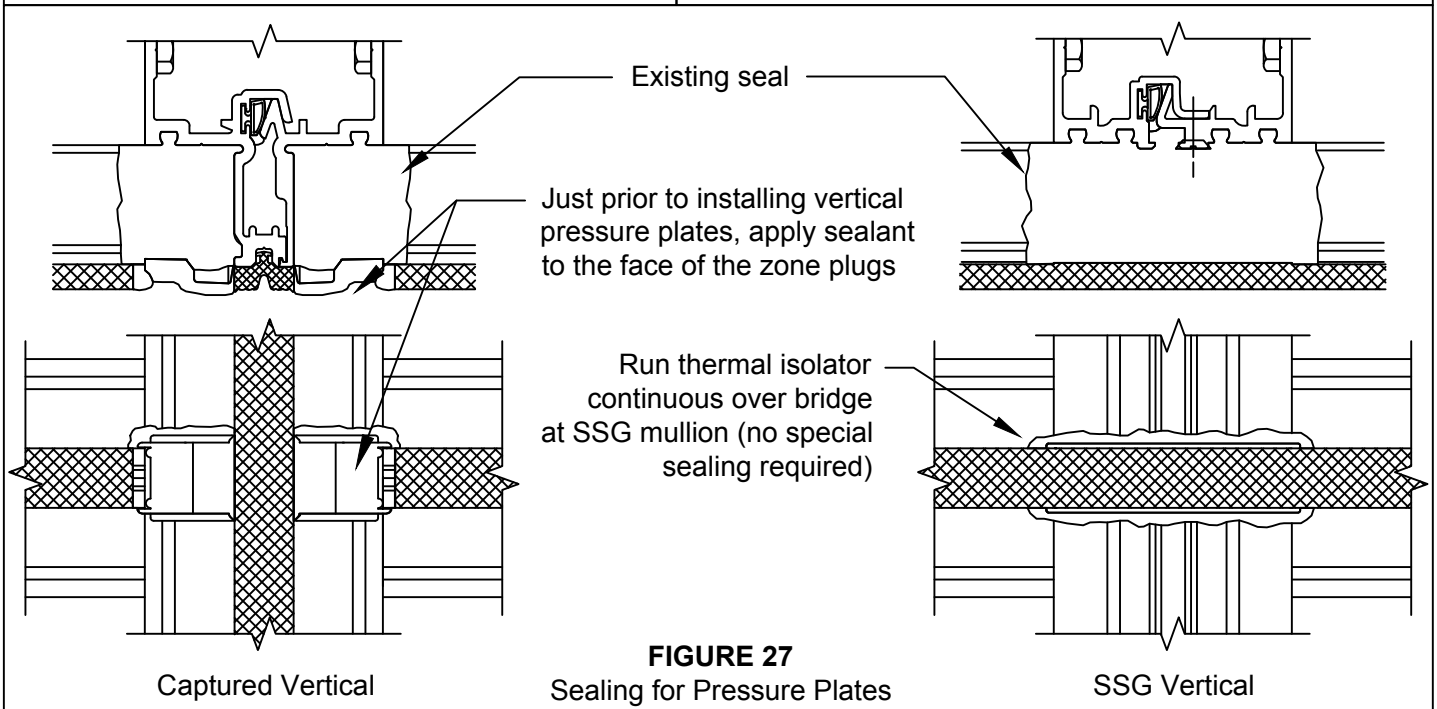

**FIGURE 27**  
Sealing for Pressure Plates

# RELIANCE™-SS CURTAIN WALL INSTALLATION MANUAL

## GLAZING

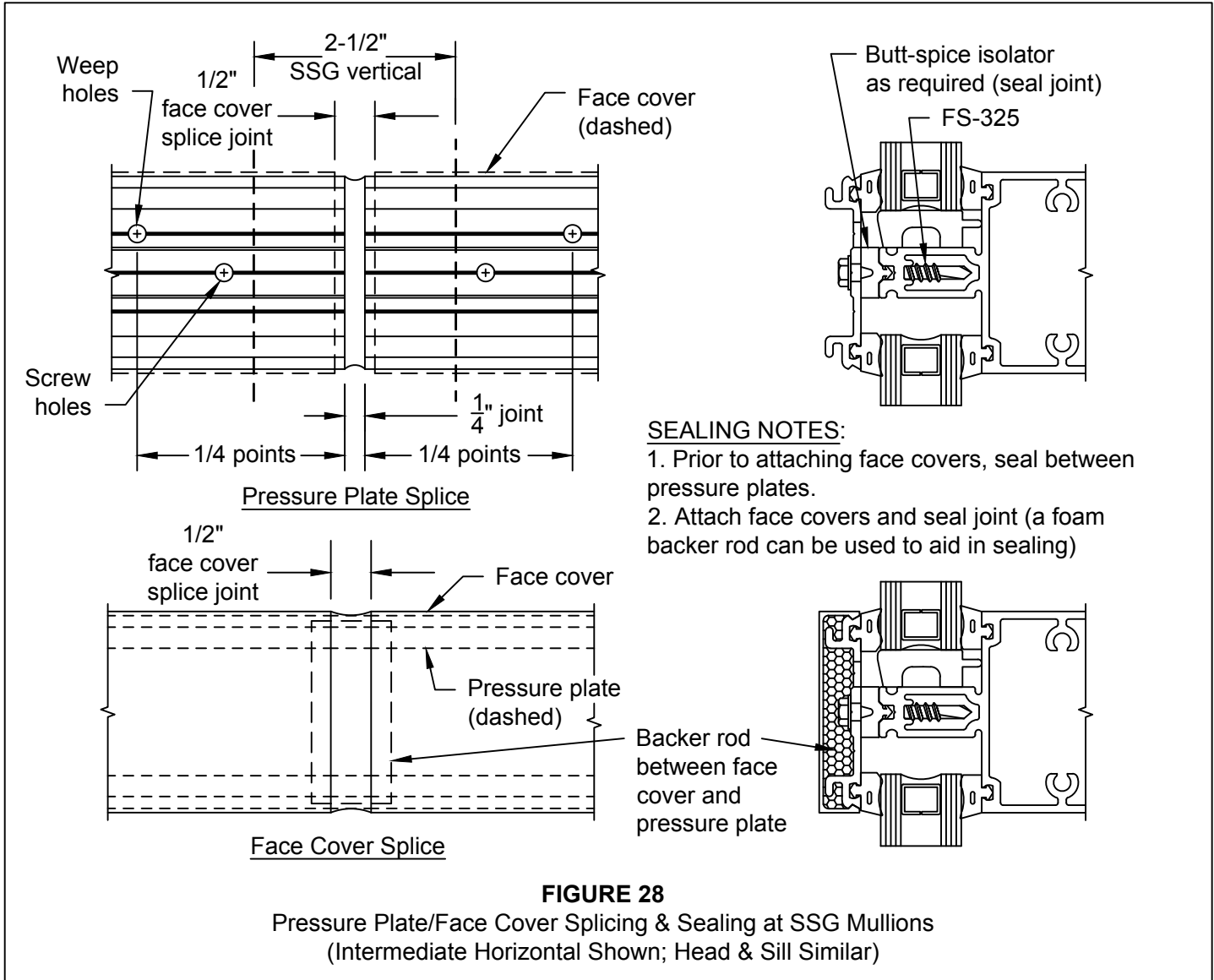

### SEALING NOTES:

1. Prior to attaching face covers, seal between pressure plates.
2. Attach face covers and seal joint (a foam backer rod can be used to aid in sealing)

- 4.10 After removing vertical temporary retainers, install vertical pressure plates with FS-325 screws, holding the pressure plates back 1/8" from the ends of the vertical mullion. **DO NOT OVERTORQUE.**
- 4.11 After removing horizontal temporary retainers, center horizontal pressure plates in opening, leaving 1/8" gap on each end. Make sure that weep holes are on the top side of the pressure plate. Install using FS-325 screws. **DO NOT OVER TORQUE. NOTE: Horizontal pressure plates and face covers run continuous over SSG mullions, not to exceed 3 lites in length. SEE FIGURE 28 for splicing and sealing instructions.**
- 4.12 After all pressure plates are installed on the frame, torque the FS-325 screws to 90 in-lbs. The use of either a drill motor with a torque limiter or torque wrench can be used. If using a cordless drill, check torque periodically since battery usage may affect the torque setting.
- 4.13 Install vertical face covers. Using a wood block to protect the cover, apply with a dead blow soft face hammer. Pin the vertical face covers once per length as required, concealing pin at a horizontal location.
- 4.14 Insert backer rod into cavity at the top (head) of each vertical mullion. Seal off end of vertical, sloping sealant back to marry with the perimeter seal. **SEE FIGURE 29, page 28.**

# RELIANCE™-SS CURTAIN WALL INSTALLATION MANUAL

## GLAZING

4.15 Seal horizontal pressure plates against the vertical face covers. Tool sealant into the joint. **SEE FIGURE 30.**

4.16 Install horizontal face covers, leaving an equal gap at each end. Make sure the weep hole in the face cover is facing down.

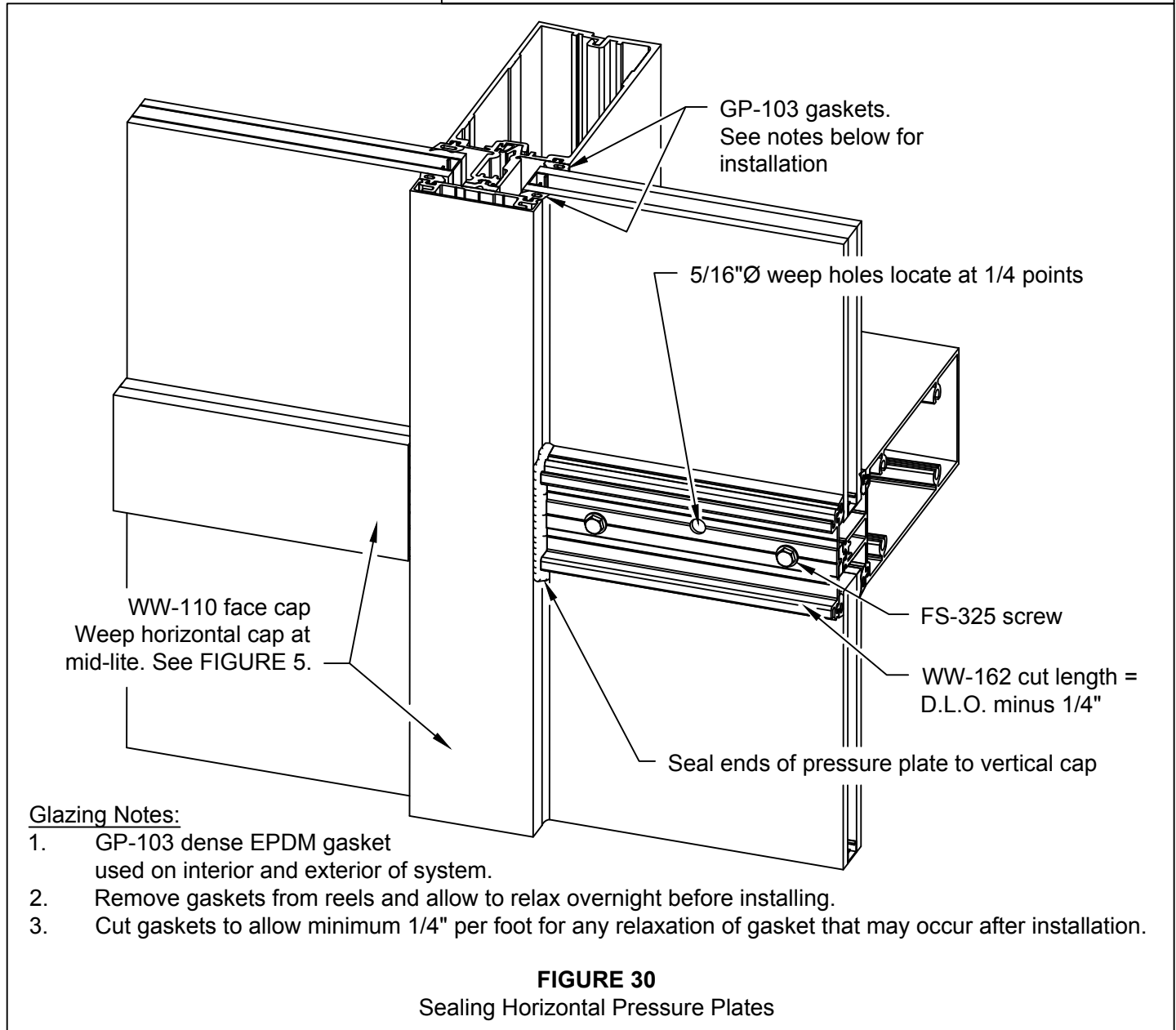
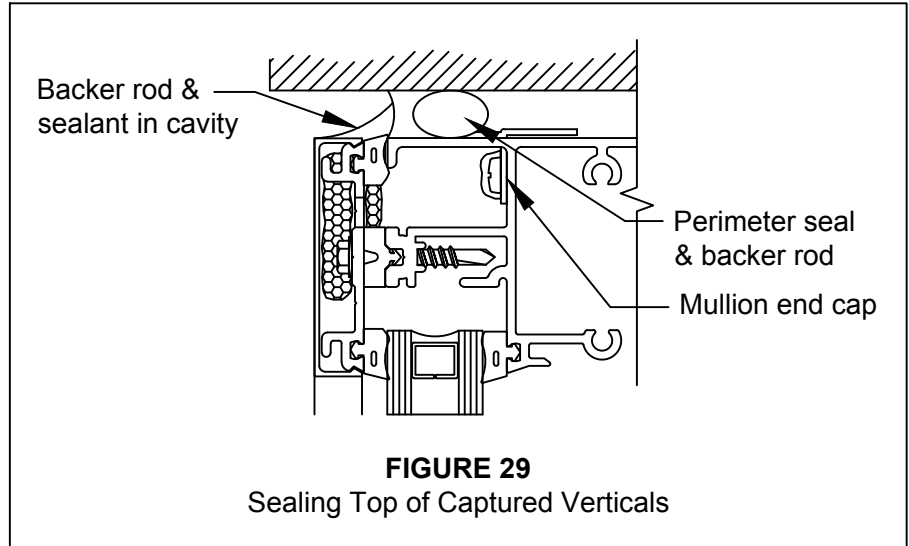

### Glazing Notes:

1. GP-103 dense EPDM gasket used on interior and exterior of system.
2. Remove gaskets from reels and allow to relax overnight before installing.
3. Cut gaskets to allow minimum 1/4" per foot for any relaxation of gasket that may occur after installation.

# RELIANCE™-SS CURTAIN WALL INSTALLATION MANUAL

## TRANSITION GLAZING

Refer to "VERTICAL SPLICING" section, page 30, for instructions on sealing adaptors at vertical mullion splices.

A.1 Install vertical adaptors first, leaving an equal overlap into each pocket. For captured verticals and all horizontals, insert the leg into the vertical reveal, then snap the hook side into the glazing reglet. **SEE FIGURE 31.** Refer to **VERTICAL SPLICING, page 30,** if vertical mullion is spliced within a spandrel lite. Transition adaptors must be installed after mullion splice is sealed.

A.2 For SSG mullions, install adaptor legs into the mullion glazing reglets. Secure to mullion with FS-119 #10 x 1 3/8" Phillips Flat Head screw 3" from the ends and 12" O.C. Cap seal screws. **SEE FIGURE 31.**

A.3 Install horizontal adaptors maintaining an equal gap at each end. **Note: For horizontal adaptors that are adjacent to SSG mullions, a small notch must be made to the tongue engagement hook in order to clear the SSG mullion bridge. SEE FIGURE 32.** Once all adaptors have been installed in the opening, seal all joints between the vertical and horizontal adaptors. Run a bead of sealant in the groove formed between the adaptor and mullion. This seal must be continuous around the opening and must marry with the seal at the horizontal to vertical adaptor joints. **SEE FIGURE 33.**

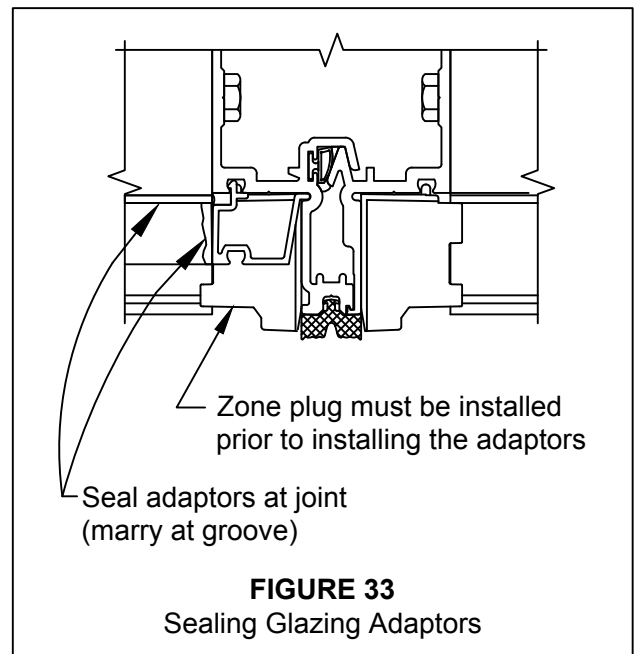
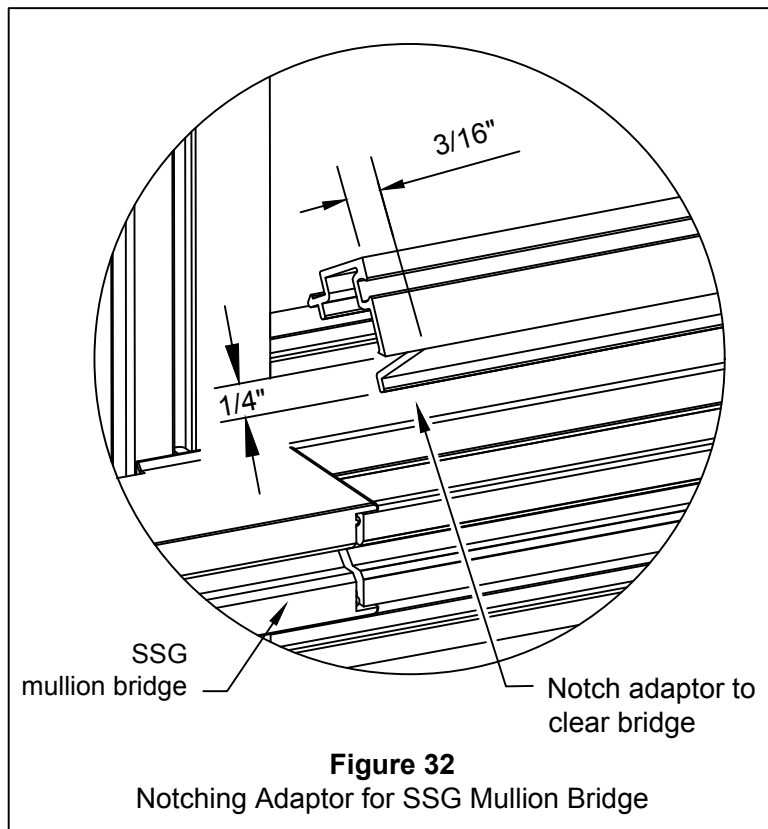
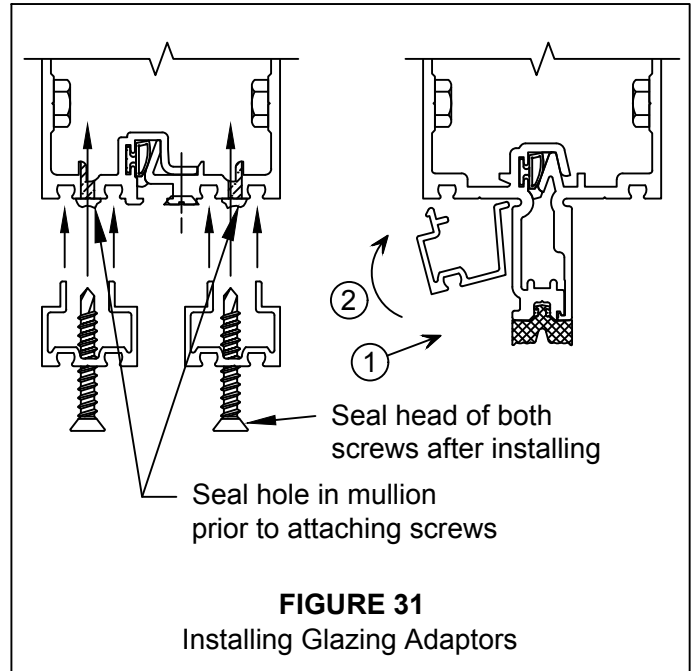

# RELIANCE™-SS CURTAIN WALL INSTALLATION MANUAL

## VERTICAL SPLICING

Follow sealant manufacturer's guidelines for proper joint width based on anticipated movement. A minimum 1/2" joint is recommended. **Note: Standard splice joints are engineered to accommodate thermal expansion only. They do not allow for movement in floor levels.** Refer to approved shop drawings for special circumstances, or contact your nearest Oldcastle Glass Engineered Products facility.

- B.1 Apply bond breaker tape to the face of splice sleeves, returning back on the sides 1" minimum. Insert backer rod into the hollow at the top of the lower vertical mullion, sealing this void. Seal between top and bottom mullions from the front of the tongue to 1" behind the glass pocket. Follow the contour of the glazing reglets with the sealant to ensure a good seal when gaskets are installed. **SEE FIGURE 34.**

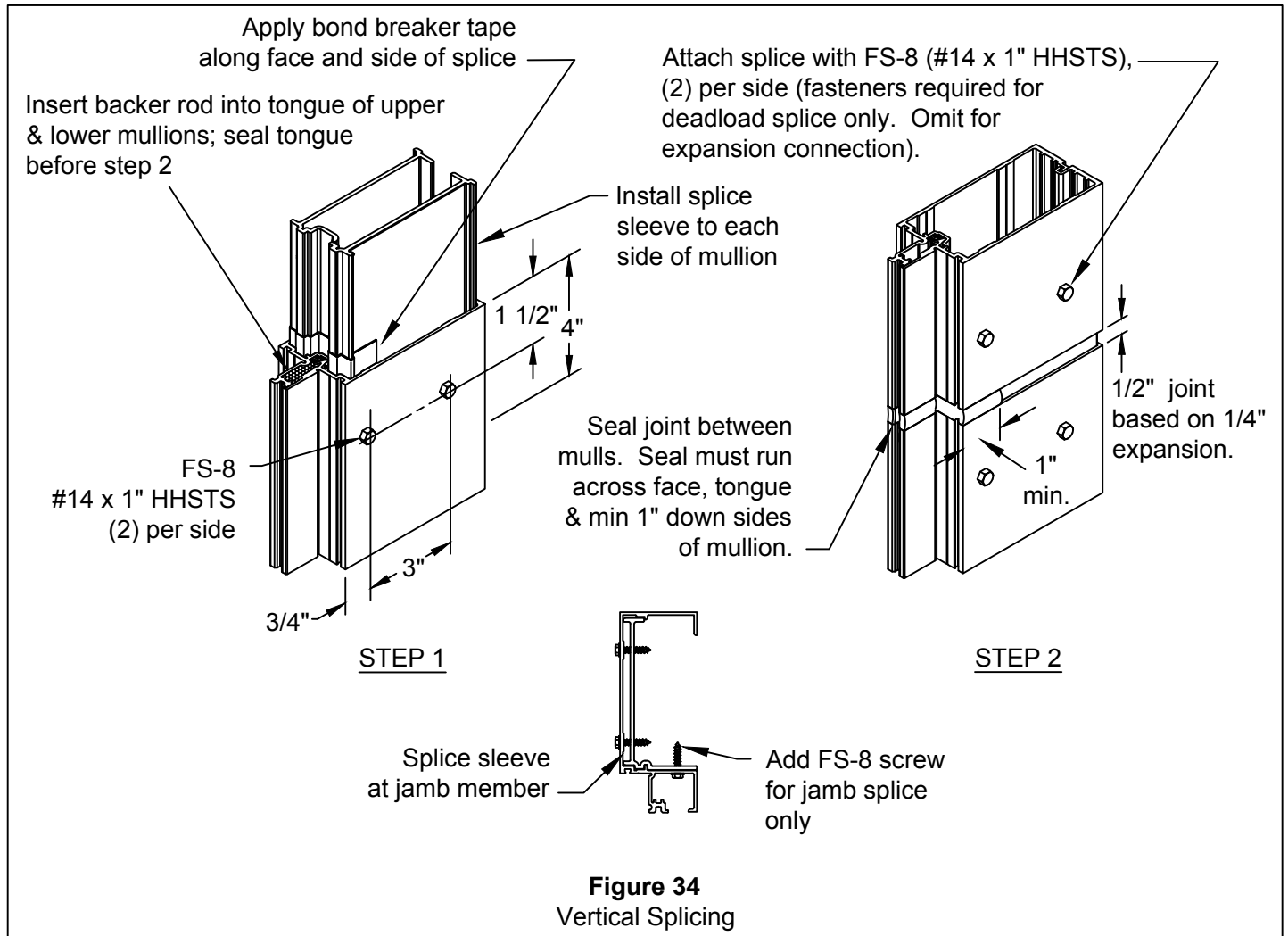

- B.2 **CAPTURED MULLION SPLICES:** Splices can be located between horizontals. Discontinue glazing adaptors at splice joints. Install backer rod into cavity and seal between adaptors. Marry adaptor seal with main mullion seal. Refer to step B.1 above for sealing notes at glazing reglets.
- B.3 **SSG MULLION SPLICES:** Splices must be located directly below a horizontal. Run horizontal adaptor through, stopping the vertical adaptor at the mullion splice. Notch horizontal adaptor to clear vertical mullion and seal per **FIGURE 35, page 31.**
- B.4 Offset pressure plates and face covers per **FIGURE 36, page 31**, sealing pressure plate and face cover joints as shown in **FIGURE 37, page 32.**

# RELIANCE™-SS CURTAIN WALL INSTALLATION MANUAL

## VERTICAL SPLICING

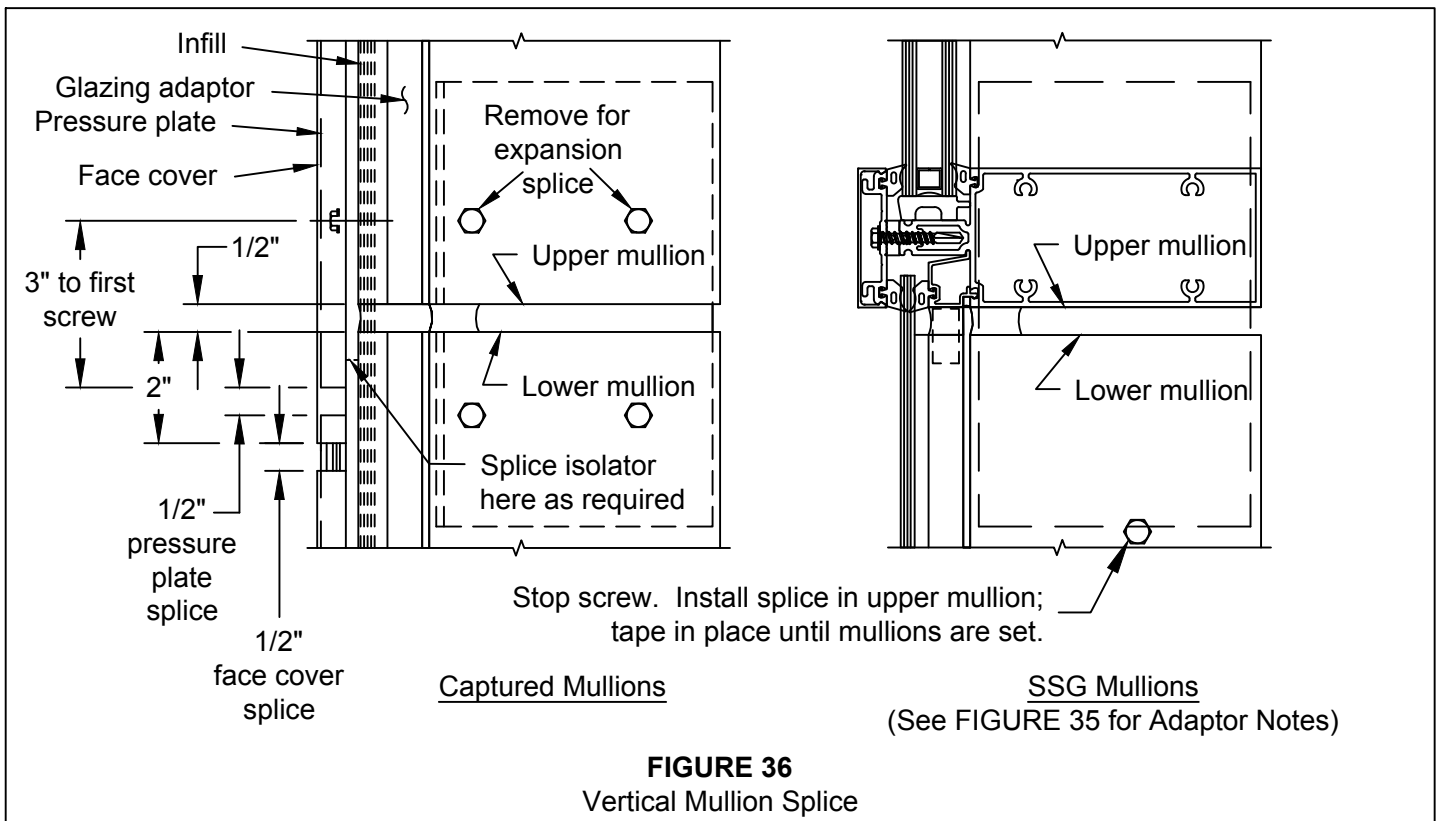
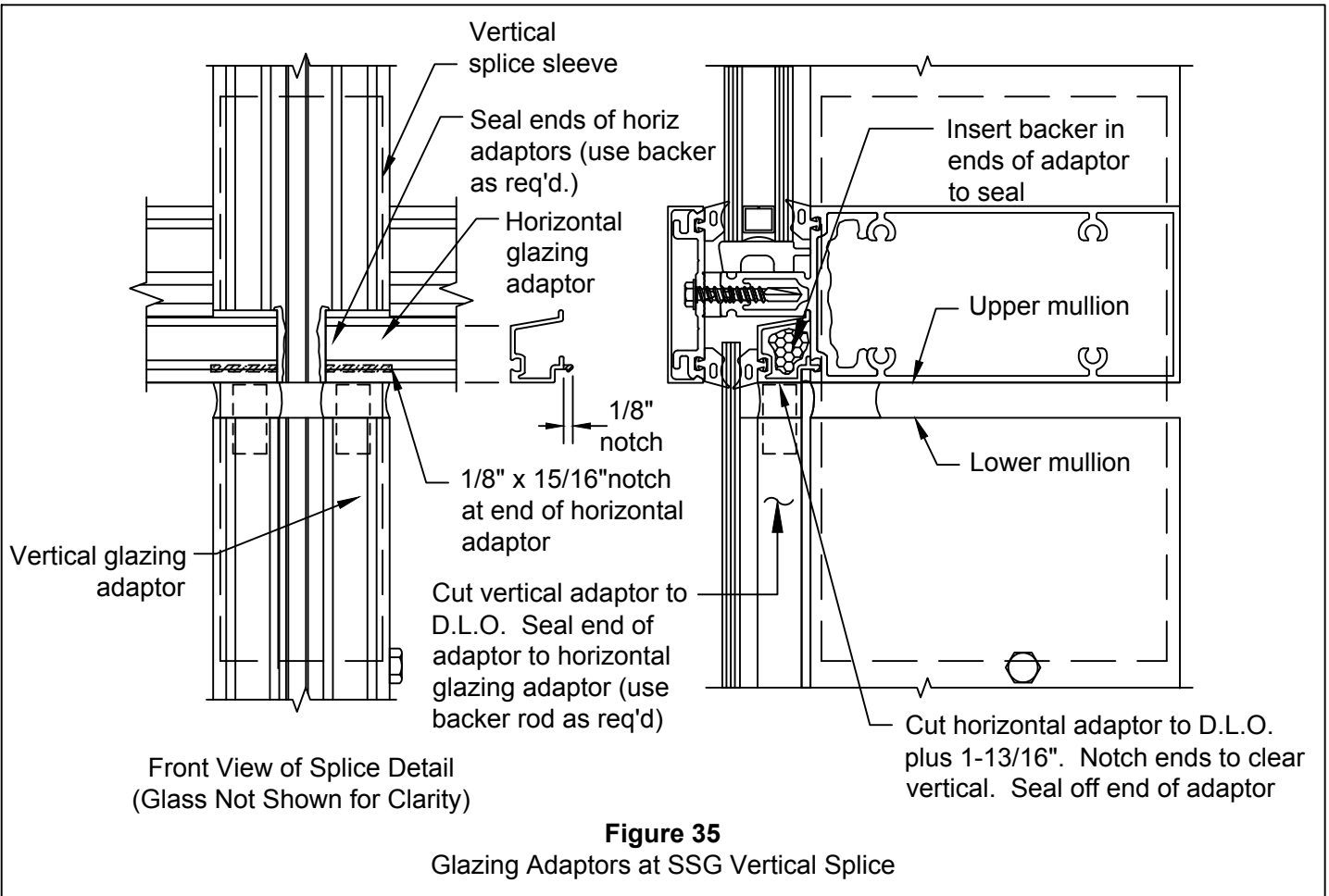

# RELIANCE™-SS CURTAIN WALL INSTALLATION MANUAL

## VERTICAL SPLICING

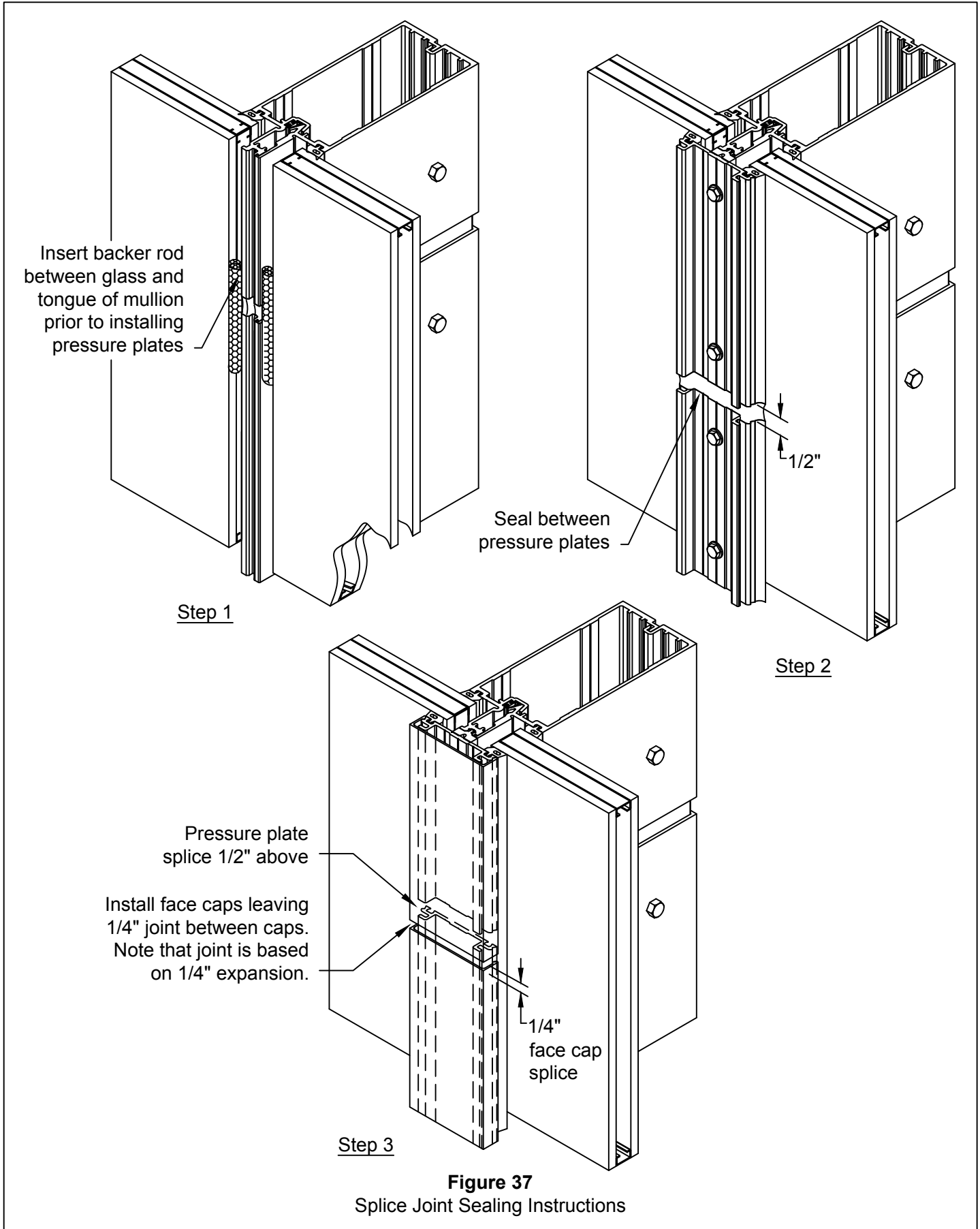

# RELIANCE™-SS CURTAIN WALL INSTALLATION MANUAL

## ENTRANCE FRAMES

All door framing components are shipped fabricated from the factory. The main curtain wall framing can be erected prior to installing the doors. Depending on the subframe used, lites adjacent to doors must be temporarily secured in place until door framing is installed. Refer to FIGURE 42, page 36 for door header fabrication and installation instructions.

C.1 Curtain wall verticals and door subframes run through to finished floor. Bed adjacent curtain wall verticals in sealant and anchor to floor per approved shop drawings.

### C.2 SUBFRAME INSTALLATION:

C.2.1 Attach TH-44 threshold clip to bottom of each jamb subframe with two (2) FS-256 #8 x 1 1/2" Phillips Round Head screws.

C.2.2 Install PVC thermal isolator into curtain wall vertical glazing reglet. Hold in place with FS-7 #10 x 3/4" PFH screw if necessary. **SEE FIGURE 38.**

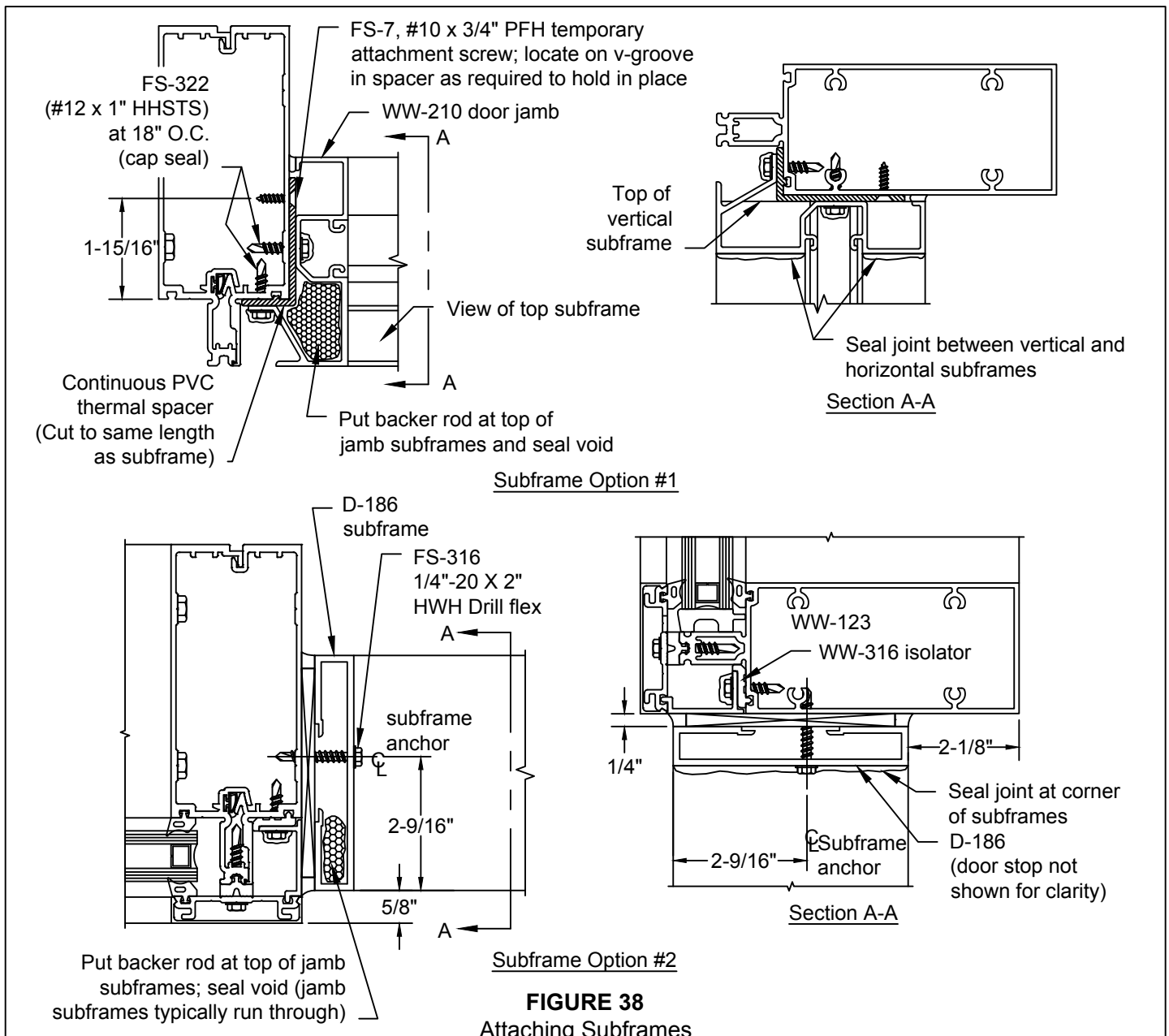

# RELIANCE™-SS CURTAIN WALL INSTALLATION MANUAL

## ENTRANCE FRAMES

C.2.3 Bed subframes in sealant. Anchor to curtain wall framing members with Drill Flex Hex Head screw at 18" O.C. Cap seal all fasteners and seal joint between jamb and header subframes. Seal tops of the jamb subframes. **SEE FIGURE 39.**

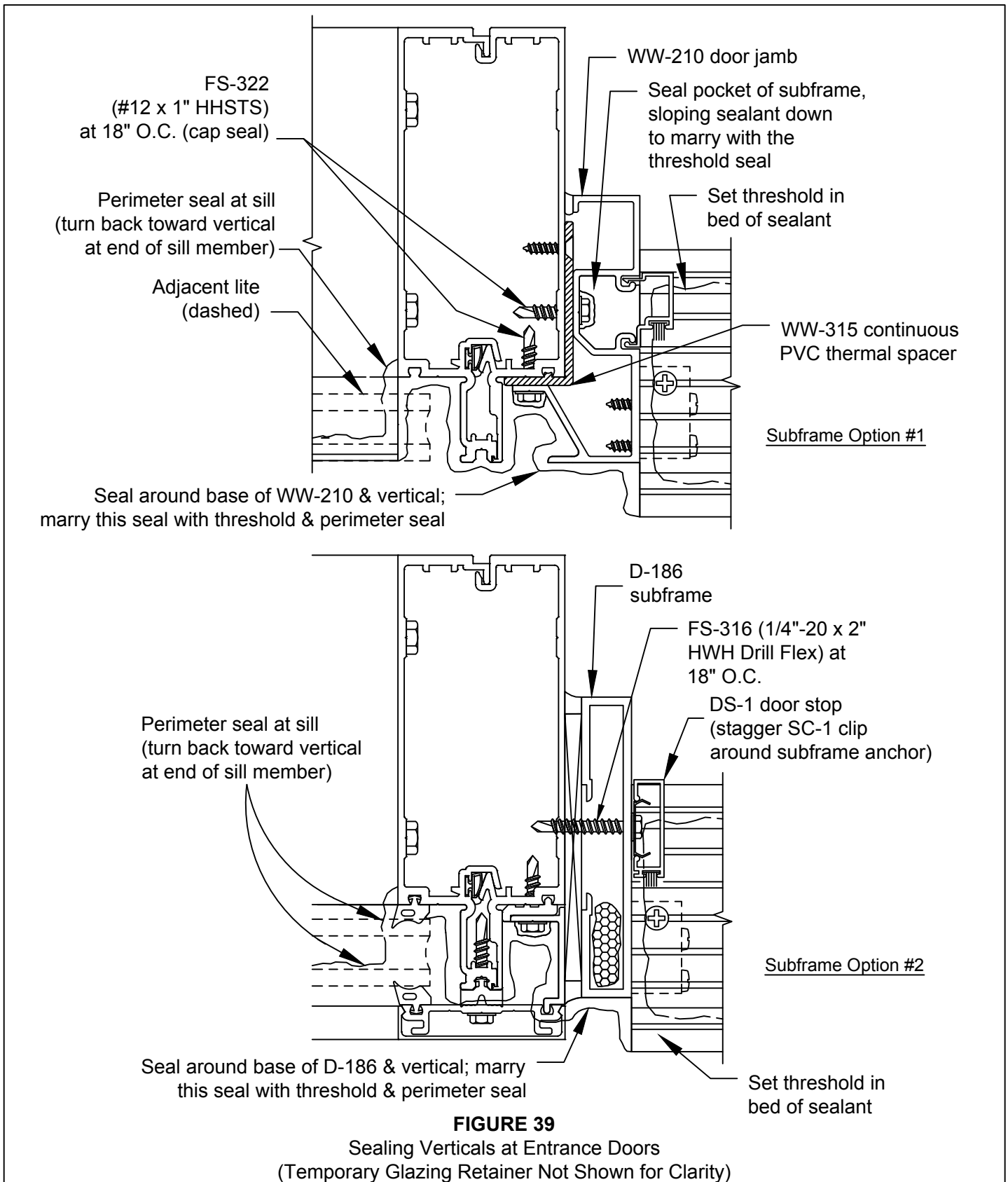

# RELIANCE™-SS CURTAIN WALL INSTALLATION MANUAL

## ENTRANCE FRAMES

C.2.4 Bed threshold in sealant, attaching to TH-44 clips with FS-42 #12 x 1/2" Phillips Flat Head screws. Marry threshold seal with subframe and main system seal. **SEE FIGURE 39, page 34.**

C.2.5 Install door stops in subframe. The vertical stops run through.

C.2.6 Install pressure plates and face covers per standard installation instructions.

C.2.7 Install door per DOOR & FRAME INSTALLATION AND GLAZING MANUAL.

### C.3 FLUSH DOOR INSTALLATION:

C.3.1 Drill 1/2" diameter access holes in flush door pressure plates 1-1/2" from ends and 12" O.C. **SEE FIGURE 40.**

C.3.2 Attach TH-44 threshold clip to bottom of each vertical pressure plate with two (2) FS-256 #8 x 1 1/2" Phillips Round Head screws.

C.3.3 Complete the glazing adjacent to the door frame, installing the flush door pressure plates per standard procedures previously outlined. Bed vertical pressure plates in sealant at sill and attach through access holes to mullion with FS-43 #12 x 3/4" Phillips Pan Head screw 1-1/2" from each end & 12" O.C. **SEE FIGURE 41 (below) & 43 (page 36).**

C.3.4 Apply continuous seal to horizontal tongue before installing horizontal pressure plate. Seal ends of horizontal pressure plate to the vertical pressure plates. **SEE FIGURE 42, page 36.**

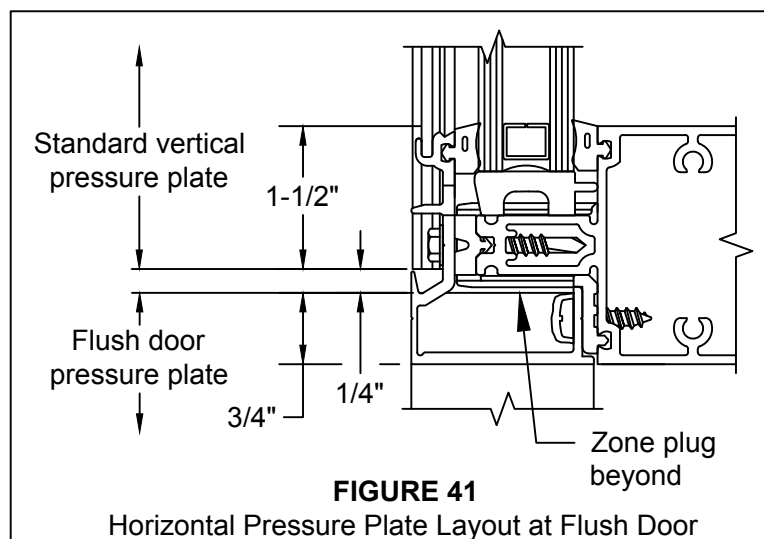
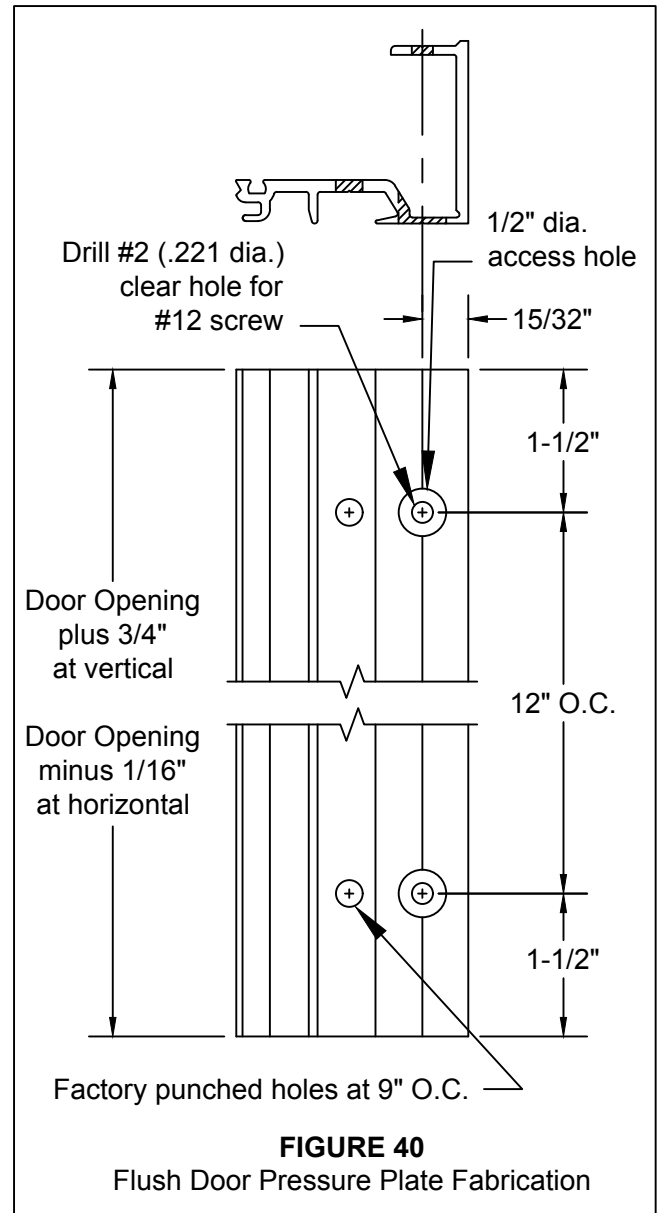

C.3.5 Bed threshold in sealant, attaching to TH-44 clips with FS-42 #12 x 1/2" Phillips Flat Head screws. Marry threshold seal with subframe and main system seal. **SEE FIGURE 43, page 36.**

C.3.6 Drill #11 (.191 dia.) holes in curtain wall mullions for FS-15 drive rivets. Install door stops onto mullion with SC-1 clips at 18" O.C. **SEE FIGURE 44, page 36.** Vertical stops run through.

# RELIANCE™-SS CURTAIN WALL INSTALLATION MANUAL

## ENTRANCE FRAMES

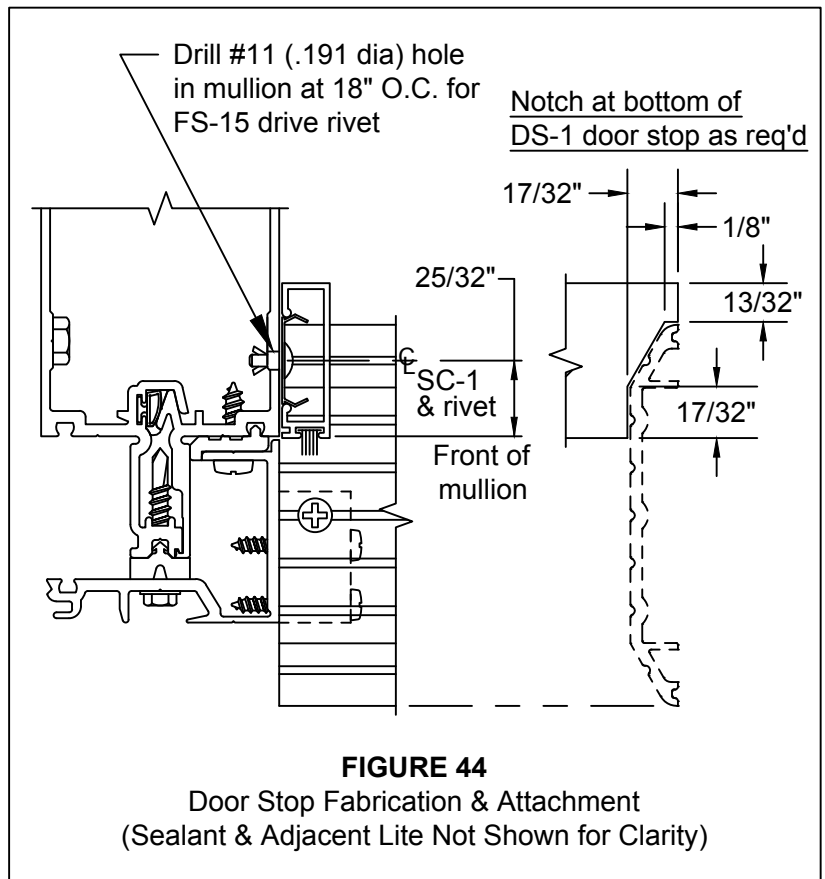
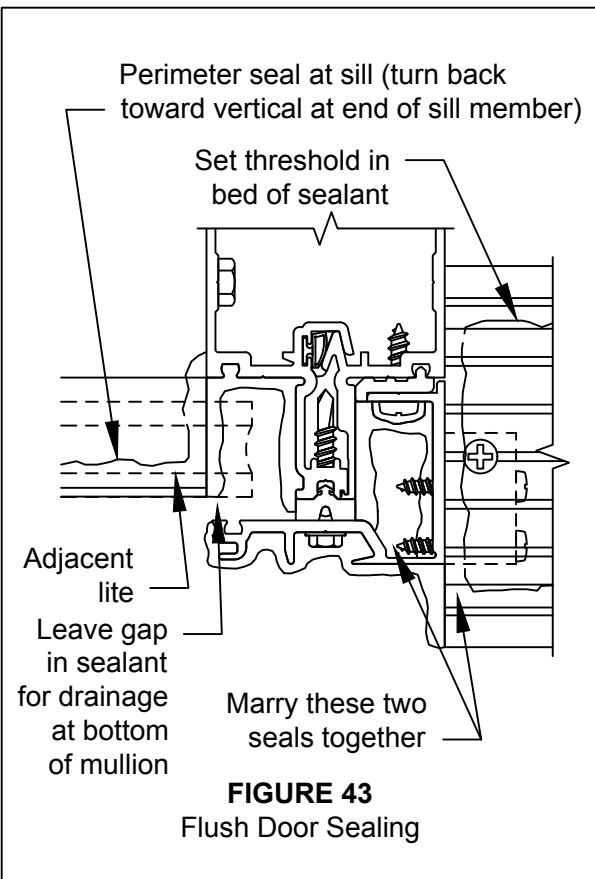
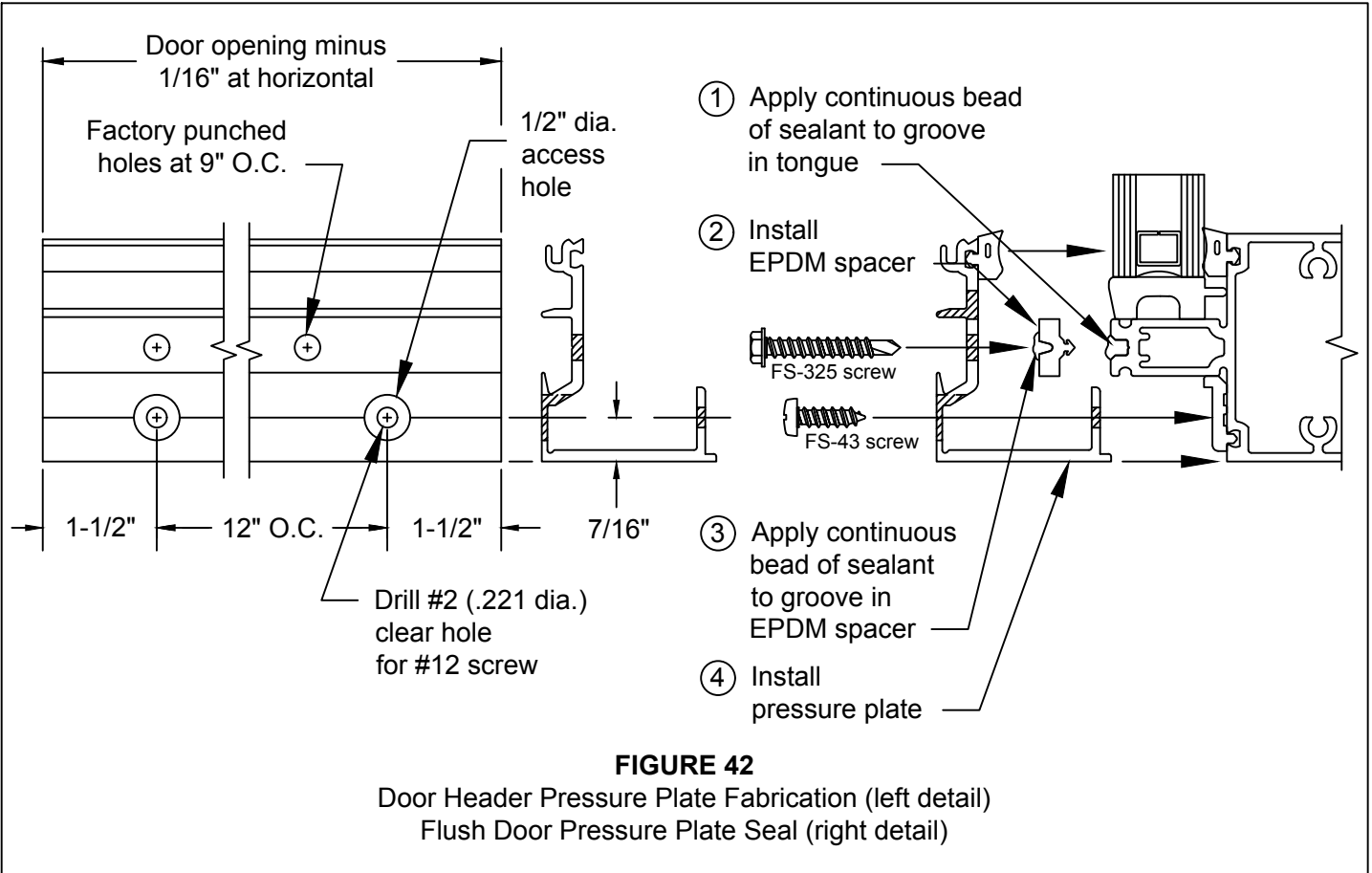

# RELIANCE™-SS CURTAIN WALL INSTALLATION MANUAL

## ENTRANCE FRAMES

C.3.7 Install face covers onto pressure plates. **SEE FIGURE 45.**

C.3.8 Install door per DOOR & FRAME INSTALLATION AND GLAZING MANUAL.

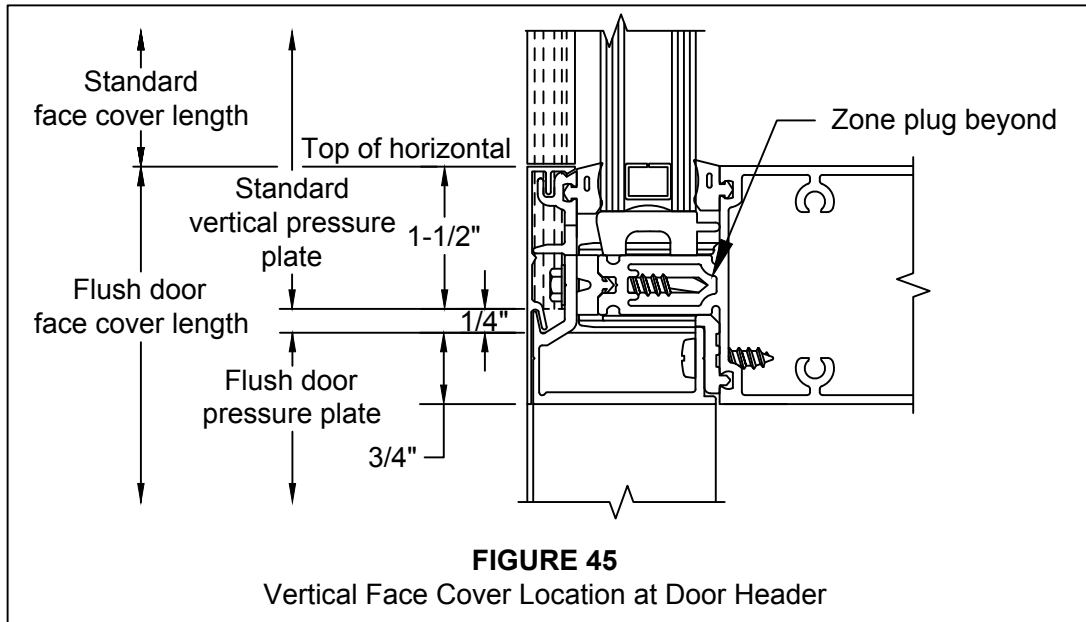

## REGLAZING PROCEDURES

- D.1 **REGLAZING MUST BE DONE FROM THE EXTERIOR.** Carefully remove face covers surrounding the lite of glass to be deglazed. **SEE FIGURE 46.**
- D.2 Remove vertical and horizontal pressure plates adjacent to the lite that must be replaced. Temp surrounding glass in place with WW-333-01 temporary glazing retainers. Torque to 60 in-lbs. Refer to step 4.6, page 27 for instructions on the location of glazing retainers.
- D.3 Remove lite of glass and existing gaskets from opening. Clean debris and sealant from aluminum framing members and pressure plates.
- D.4 Install new gaskets into framing and install new lite of glass. See GLAZING section of this manual for proper procedure.
- D.5 Reinstall pressure plates and seals per GLAZING section of this manual.

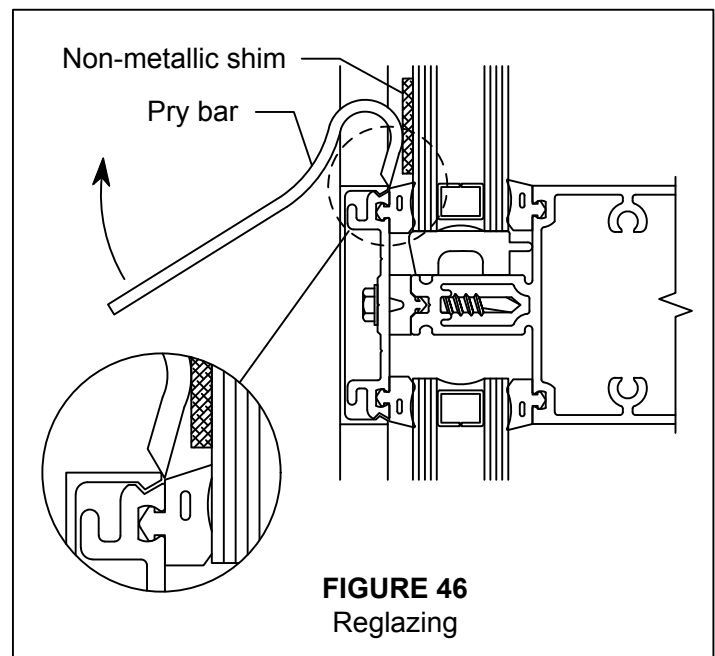

## MULLION REINFORCING

**FIGURE 47** shows the typical attachment method for reinforcing in the vertical mullion. Refer to approved shop drawings for placement, size and quantity of reinforcing required.

Refer to Wind Load Charts in the Detail Catalog for single span and equal twin span conditions (unbraced lengths less than 8.11 feet). For all other conditions such as unequal twin spans, knee brace and multi-span conditions, contact your local Oldcastle Glass Engineered Products facility for mullion reinforcing requirements.

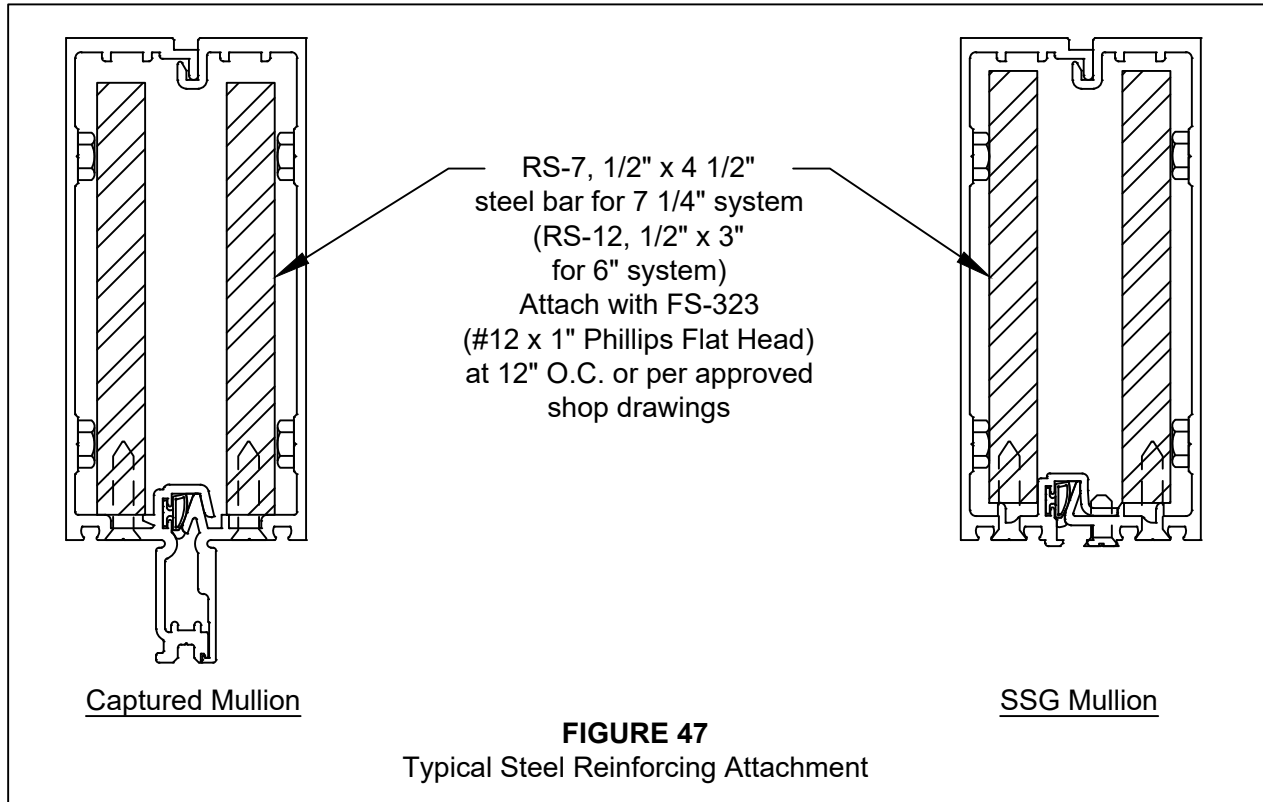

## CORNER MULLIONS

**FIGURE 48** through **FIGURE 54** shows the basic layout of the standard one-piece corner mullion assemblies. These details are for general reference and do not necessarily reflect all conditions. For specific assembly, sealing and anchoring notes, refer to approved shop drawings.

Using a one-piece corner mullion in the Reliance-SS system requires the pre-assembly of corner sections. For the first bay on either side of the corner mullions, attach the standard screw spline horizontal members to a 90° corner mullion with the WW-280-01 shear block at intermediate horizontals and WW-281-01 and -02 at head/sill members. For 135° corners, use the WW-280-02 shear block at intermediate horizontals and WW-281-03 and -04 at head/sill members. The other end of the horizontal members can be attached to the intermediate mullion halves using the screw splines.

# RELIANCE™-SS CURTAIN WALL INSTALLATION MANUAL

## CORNER MULLIONS

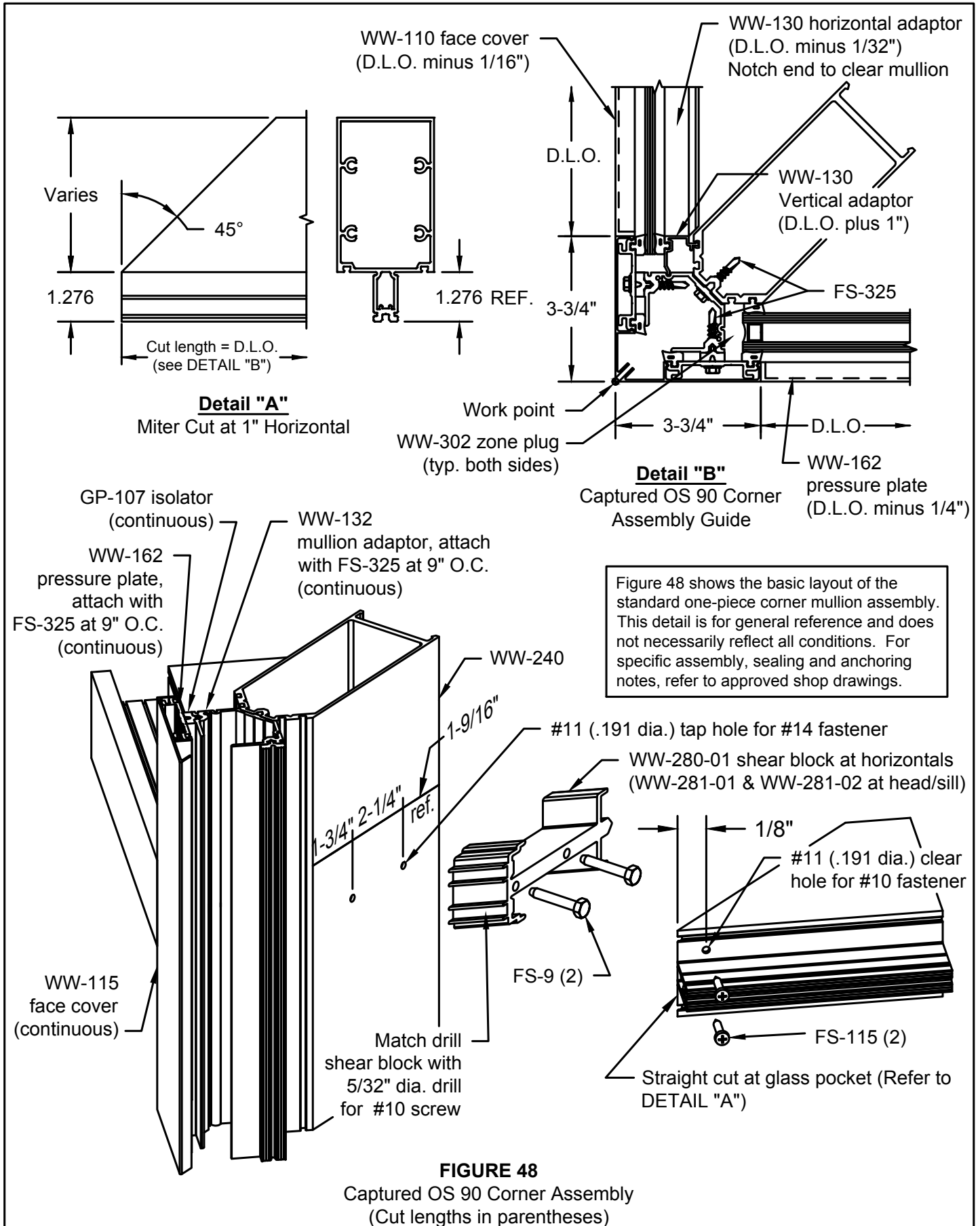

# RELIANCE™-SS CURTAIN WALL INSTALLATION MANUAL

## CORNER MULLIONS

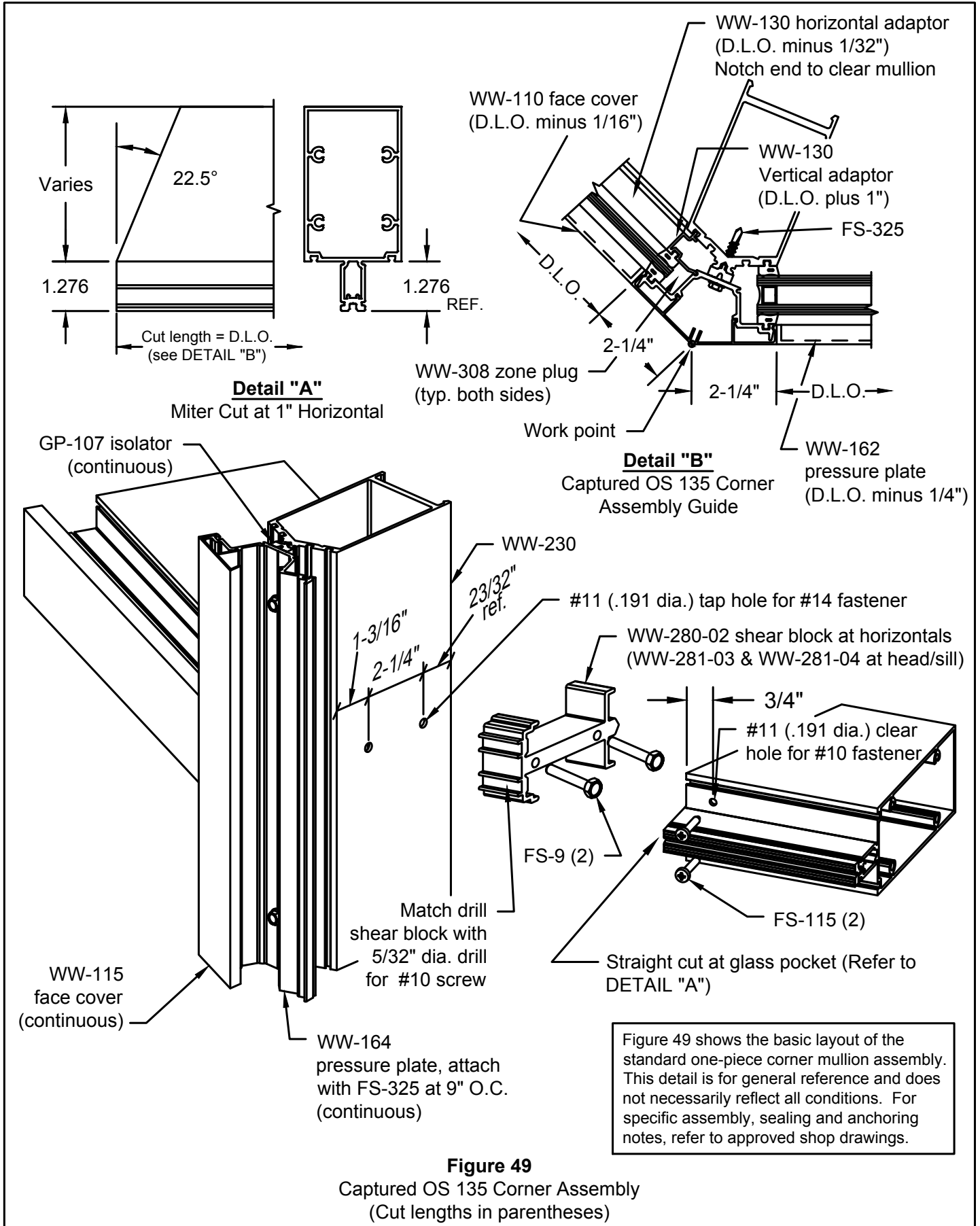

**Figure 49**  
Captured OS 135 Corner Assembly  
(Cut lengths in parentheses)

# RELIANCE™-SS CURTAIN WALL INSTALLATION MANUAL

## CORNER MULLIONS

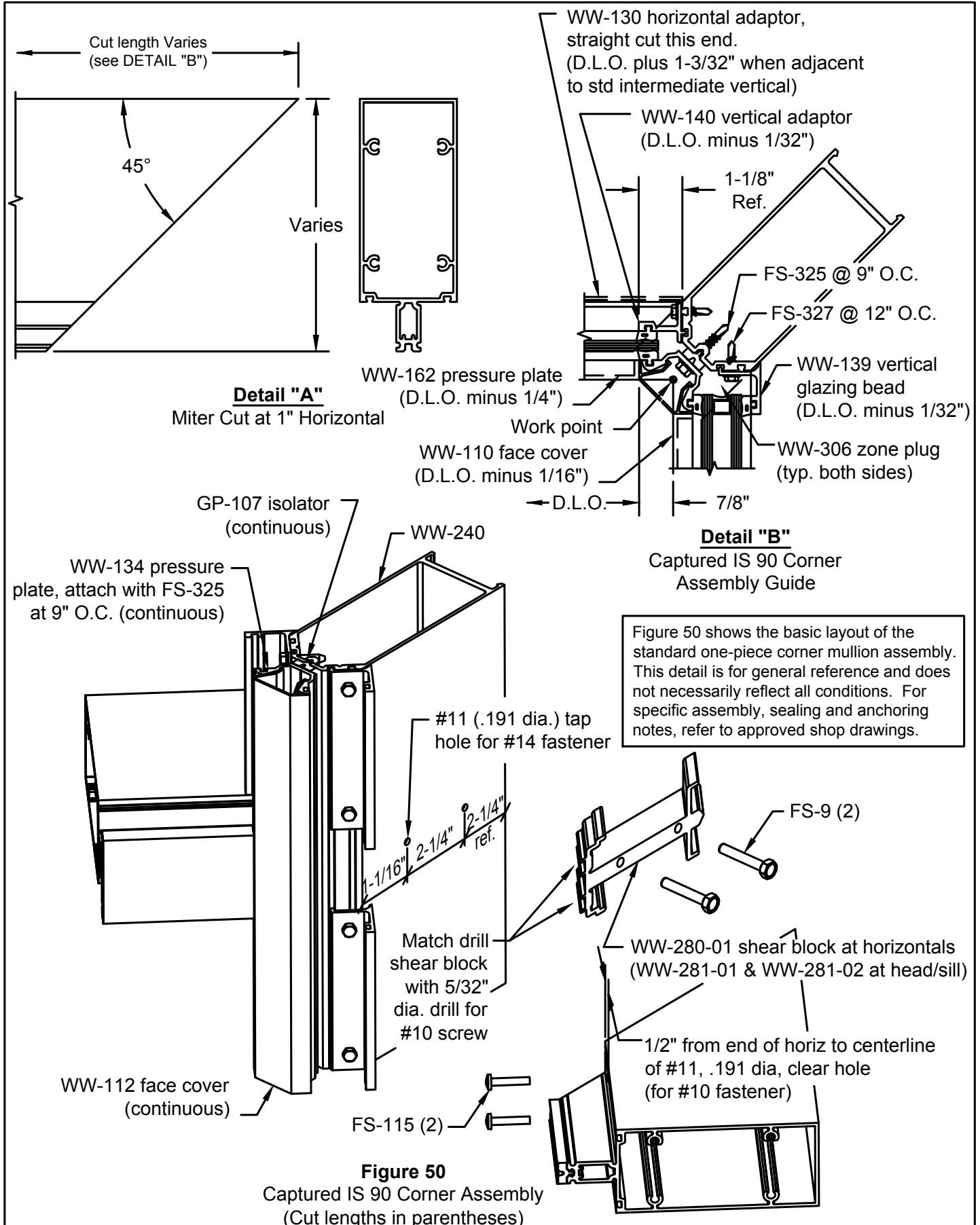

# RELIANCE™-SS CURTAIN WALL INSTALLATION MANUAL

## CORNER MULLIONS

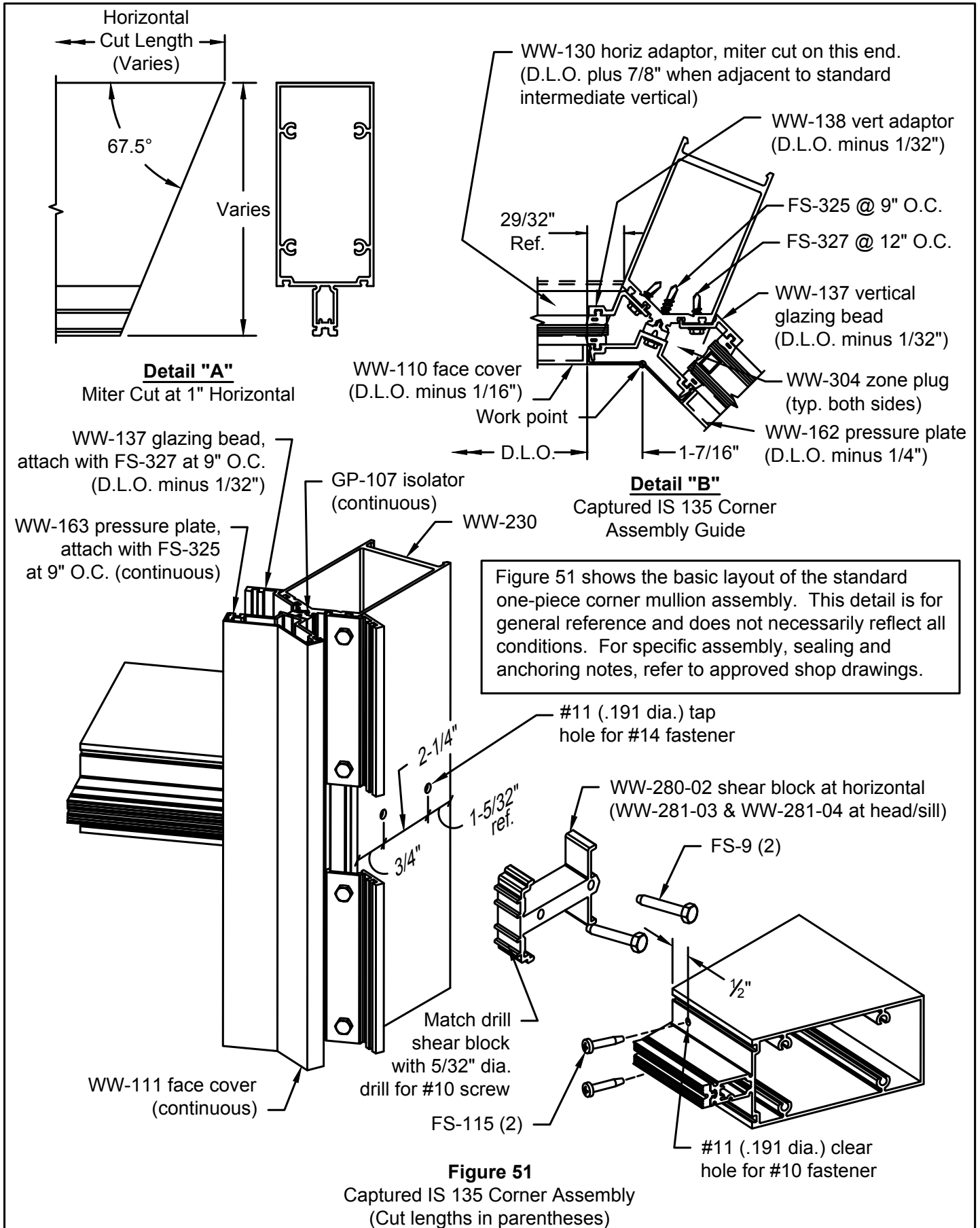

# RELIANCE™-SS CURTAIN WALL INSTALLATION MANUAL

## CORNER MULLIONS

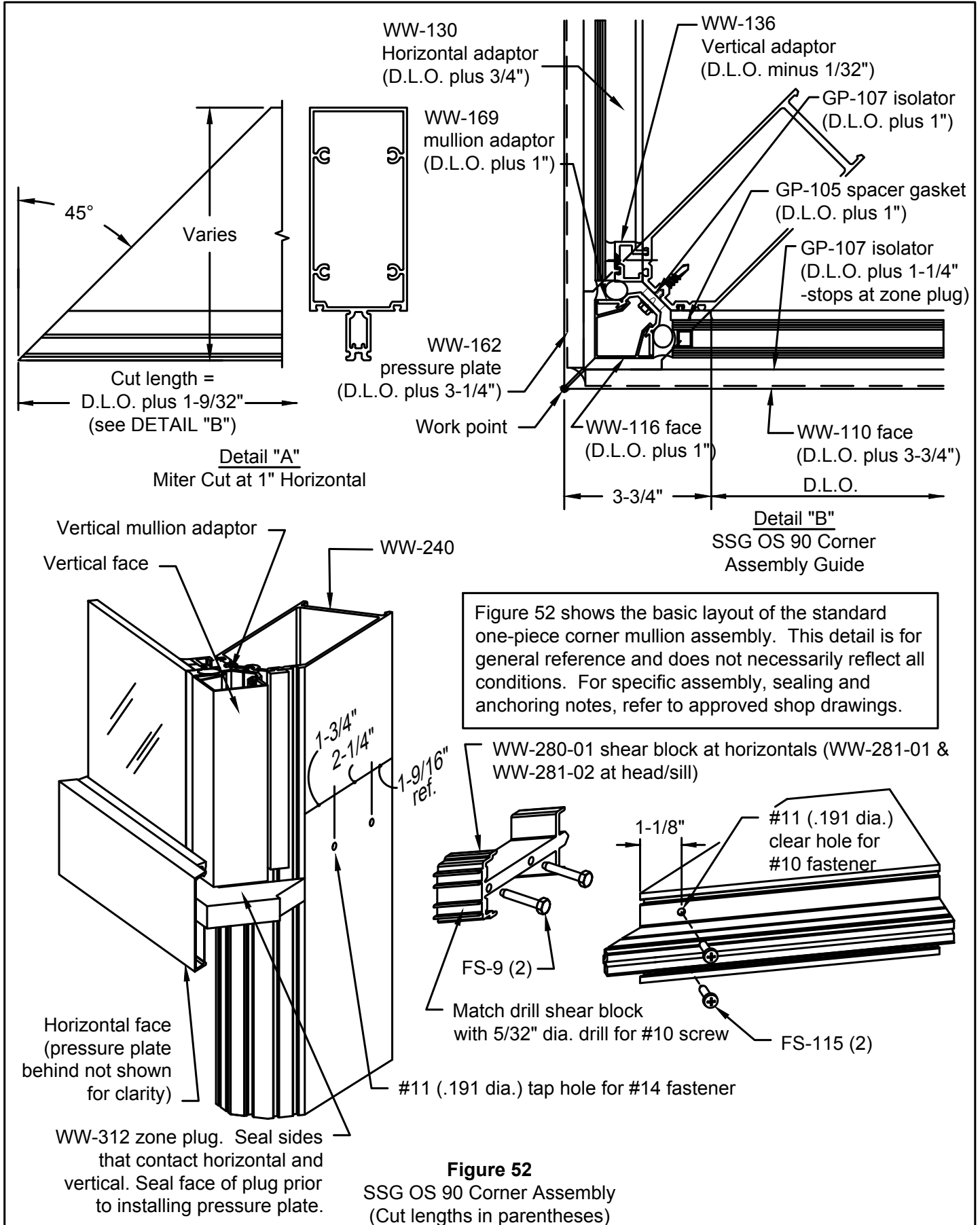
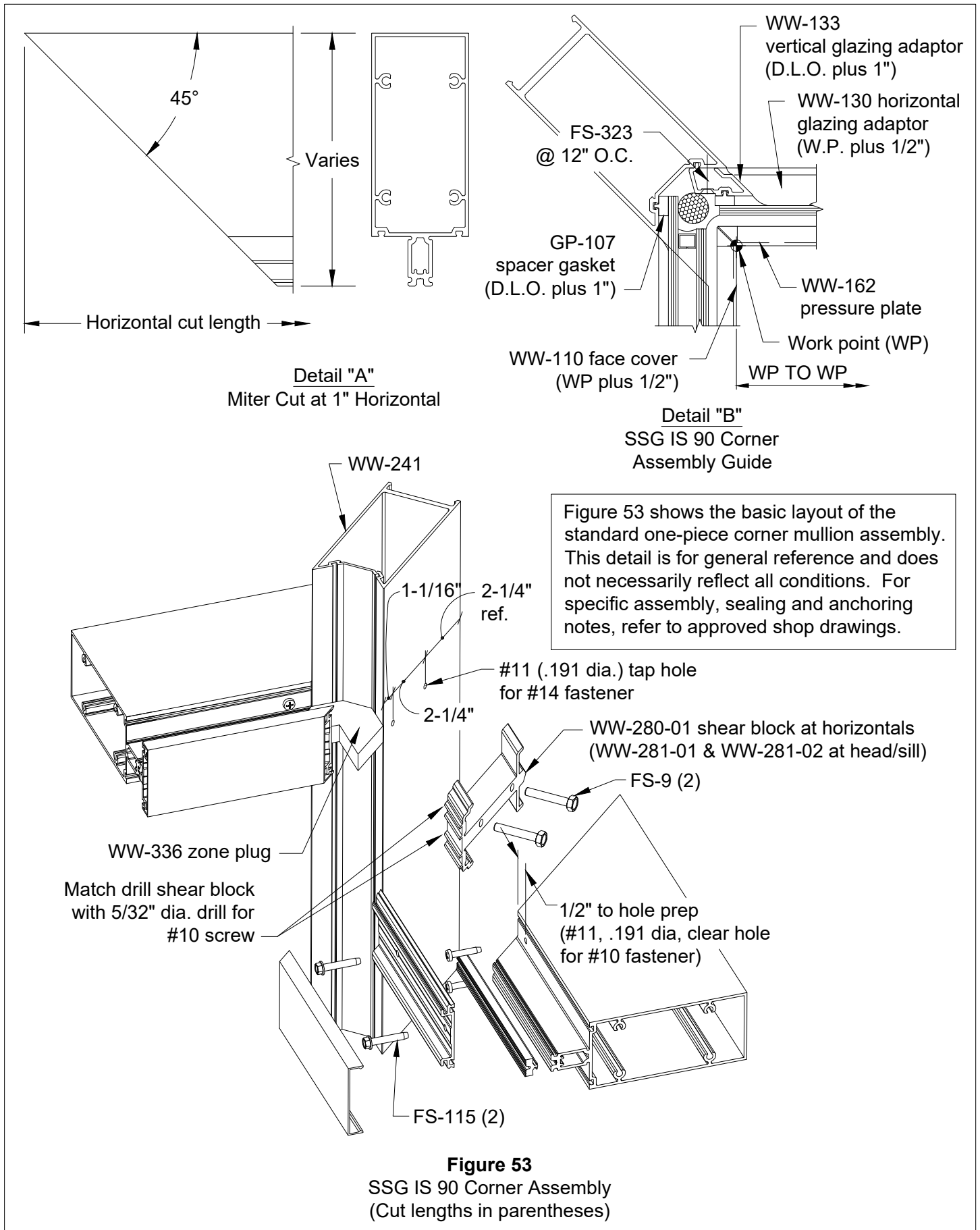

Figure 52 shows the basic layout of the standard one-piece corner mullion assembly. This detail is for general reference and does not necessarily reflect all conditions. For specific assembly, sealing and anchoring notes, refer to approved shop drawings.

**Figure 52**  
SSG OS 90 Corner Assembly  
(Cut lengths in parentheses)

# RELIANCE™-SS CURTAIN WALL INSTALLATION MANUAL

## CORNER MULLIONS



# RELIANCE™-SS CURTAIN WALL INSTALLATION MANUAL



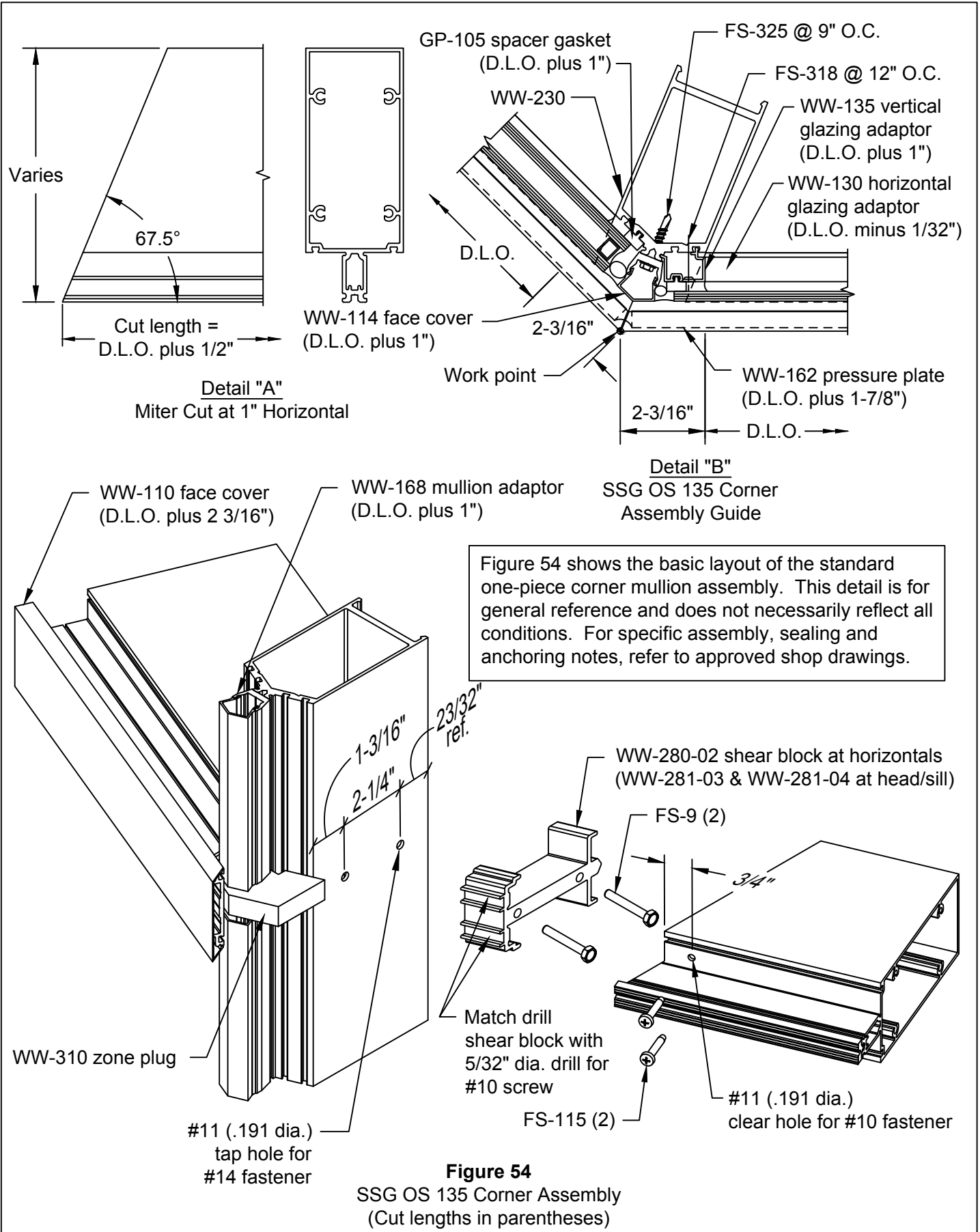



## CORNER MULLIONS



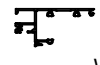
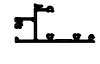
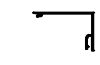

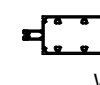

# RELIANCE™-SS CURTAIN WALL INSTALLATION MANUAL

## PARTS LIST



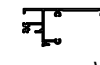

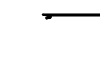
### 4" BACKMEMBERS 6" SYSTEM DEPTH

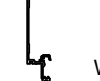
	Head
WW-446	
	Sill
WW-447	
	Head & Sill Cover
WW-448	
	Jamb
WW-443	
	Captured Vertical - Left
WW-440	
	Captured Vertical - Right
WW-441	
	SSG Vertical - Left
WW-444	
	SSG Vertical - Right
WW-445	
	Horizontal
WW-442	











### 5 1/4" BACKMEMBERS 7 1/4" SYSTEM DEPTH

	Head
WW-546	
	Sill
WW-547	
	Head & Sill Cover
WW-548	
	Jamb
WW-543	
	Captured Vertical - Left
WW-540	













### 5 1/4" BACKMEMBERS - cont'd 7 1/4" SYSTEM DEPTH

	Captured Vertical - Right
WW-541	
	SSG Vertical - Left
WW-544	
	SSG Vertical - Right
WW-545	
	Horizontal
WW-542	

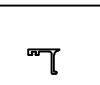
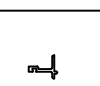
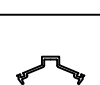
### CORNER MULLIONS & ACCESSORIES

	135° Corner Mullion Captured & SSG 7 1/4" & 6"
WW-230	
	90° Corner Mullion OS-Captured & SSG IS-Captured 7 1/4" & 6"
WW-240	
	90° Corner Mullion IS-SSG 7 1/4" & 6"
WW-241	
	135° Inside Corner Face Cap 7 1/4" & 6"
WW-111	
	90° Inside Corner Face Cap 7 1/4" & 6"
WW-112	
	135° Outside Corner Face Cap 7 1/4" & 6" (2 Per Corner)
WW-113	
	135° SSG Outside Corner Face Cap 7 1/4" & 6"
WW-114	
	90° Outside Corner Face Cap 7 1/4" & 6" (2 Per Corner)
WW-115	
	90° SSG Outside Corner Face Cap 7 1/4" & 6"
WW-116	
	90° Outside Corner Mullion Adaptor 7 1/4" & 6"
WW-132	



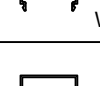







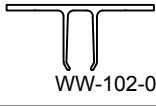
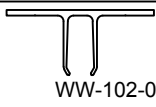
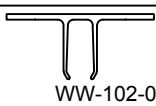

### CORNER MULLIONS & ACCESSORIES - cont'd

	90° Inside SSG Corner 1/4" Adaptor 7 1/4" & 6"
WW-133	
	90° Inside Corner Pressure Plate 7 1/4" & 6"
WW-134	
	135° SSG Outside Corner 1/4" Adaptor 7 1/4" & 6"
WW-135	
	90° SSG Outside Corner 1/4" Adaptor 7 1/4" & 6"
WW-136	
	135° Inside Corner 1" Glazing Bead 7 1/4" & 6"
WW-137	
	135° Inside Corner 1/4" Adaptor 7 1/4" & 6"
WW-138	
	90° Inside Corner 1" Glazing Bead 7 1/4" & 6"
WW-139	
	90° Inside Corner 1/4" Adaptor 7 1/4" & 6"
WW-140	
	135° Inside Corner Pressure Plate 7 1/4" & 6"
WW-163	
	135° Outside Corner Pressure Plate 7 1/4" & 6"
WW-164	
	135° Outside SSG Corner Pressure Plate 7 1/4" & 6"
WW-168	
	90° Outside SSG Corner Pressure Plate 7 1/4" & 6"
WW-169	
	90° Corner Mullion Snap-In Back Trim 6"
CW-823	
	90° Corner Mullion Snap-In Back Trim 7 1/4"
WW-220	
	135° Corner Mullion Snap-In Back Trim 7 1/4"
WW-221	













# RELIANCE™-SS CURTAIN WALL INSTALLATION MANUAL

## PARTS LIST













### CORNER MULLIONS & ACCESSORIES - cont'd

 WW-223	I.S. 90° Corner Mullion Optional Snap-In Back Trim 7 1/4"
 WW-224	O.S. 90° Corner Mullion Optional Snap-In Back Trim 7 1/4"
 WW-225	I.S. 135° Corner Mullion Optional Snap-In Back Trim 7 1/4"
 WW-226	O.S. 135° Corner Mullion Optional Snap-In Back Trim 7 1/4"
 WW-102-05	"T" Anchor for WW-240
 WW-102-06	"T" Anchor for WW-230
 WW-102-07	"T" Anchor for WW-241
 WW-280-01	90° Corner Shear Block (Horizontal)
 WW-280-02	135° Corner Shear Block (Horizontal)
 WW-281-01	90° Corner Head/Sill Shear Block (L)
 WW-281-02	90° Corner Head/Sill Shear Block (R)
 WW-281-03	135° Corner Head/Sill Shear Block (L)
 WW-281-04	135° Corner Head/Sill Shear Block (R)
 WW-190-01	Splice Sleeve for WW-230
 WW-191-01	Splice Sleeve for WW-240

### CORNER MULLIONS & ACCESSORIES - cont'd

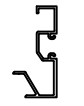
 WW-202-01	Splice Sleeve for WW-241
 WW-317	135° Inside Mullion Cap
 WW-319	90° Inside Mullion Cap
 WW-321	135° Outside Mullion Cap
 WW-323	90° Outside Mullion Cap
 WW-337	90° Inside SSG Mullion Cap
 WW-304	Zone Plug 135° Captured I.S.
 WW-306	Zone Plug 90° Captured I.S.
 WW-308	Zone Plug 135° Captured O.S.
 WW-310	Zone Plug 135° SSG O.S.
 WW-312	Zone Plug 90° SSG O.S.
 WW-336	Zone Plug 90° SSG I.S.

### COMMON EXTRUSIONS All System Depths and Infills

 WW-110	Typical Face Cap
 WW-117	Flush Door Frame Face Cap
 WW-122	Pocket Filler (Use with Exterior Gasket)
 WW-123	Pocket Filler (Full Pocket)
 WW-175	Glazing Adaptor 1/4" Infill - Captured Verticals
 WW-130	Glazing Adaptor 1/4" Infill - Captured Horizontals, 90° O.S.
 WW-144	Glazing Adaptor 1/4" Infill - SSG Verticals
 WW-160	Flush Door Frame Pressure Plate
 WW-162	Typical Pressure Plate
 WW-210	Door Subframe (1" Sightline)
 D-186	Optional Door Subframe (3/4" Sightline)
 DS-1	Flush Door Frame & Optional D-186 Door Stop (Use with SC-1 Clip)
 FG-2145	Typical Snap-In Door Stop
 DS-117	Thermal Door Snap-In Door Stop

## PARTS LIST

### STANDARD ACCESSORIES All System Depths and Infills

DJ-105	Typical Drill Jig for Mullions (Non Corners)
GP-103	Typical EPDM Dense Exterior & Interior Gasket 1/4" F.C.
GP-104	Optional EPDM Interior Sponge Gasket 1/4" F.C.
GP-117	Optional EPDM Gasket 3/16" F.C.
GP-118	Optional EPDM Gasket 5/16" F.C.
GP-105	SSG Spacer Gasket Corner Mullions 1/4" F.C.
GP-106	SSG Spacer Gasket SSG Vertical & Pre-Glazed Captured Mullions 1/4" F.C.
GP-107	Thermal Isolator
GP-134	Vertical Mullion Air Seal Gasket
GP-109	1" Setting Block (2 Per Lite)
GP-110	1/4" Setting Block (2 Per Lite)
GP-111	Side Block 1" Infill
GP-112	Side Block 1/4" Infill
RS-7	1/2" x 4 1/2" Steel Bar for WW-540, WW-541, WW-544 and WW-545 (20'-1")
RS-12	1/2" x 3" Steel Bar for WW-440, WW-441, WW-444 and WW-445 (20'-1")

### STANDARD ACCESSORIES All System Depths and Infills

WW-349	SSG Mull Bridge
WW-302	Zone Plug Typical Mullion & 90° O.S. Captured
WW-174-01	"T" Anchor for WW-543, WW-540 & WW-541
WW-174-02	"T" Anchor for WW-544 & WW-545
WW-174-03	"T" Anchor for WW-443, WW-440 & WW-441
WW-174-04	"T" Anchor for WW-444 & WW-445
WW-250-01	Vertical Mullion Splice for WW-540
WW-251-01	Vertical Mullion Splice for WW-541
WW-253-01	Jamb Mullion Splice for WW-543
WW-254-01	SSG Mullion Splice for WW-544
WW-255-01	SSG Mullion Splice for WW-545
WW-260-01	Vertical Mullion Splice for WW-440
WW-261-01	Vertical Mullion Splice for WW-441
WW-263-01	Jamb Mullion Splice for WW-443
WW-264-01	SSG Mullion Splice for WW-444















### STANDARD ACCESSORIES All System Depths and Infills

WW-265-01	SSG Mullion Splice for WW-445
WW-315	Thermal Isolator for Standard Door Subframe 12' Long
WW-316	Thermal Isolator for Flush Door Subframe 12' Long
WW-355-01	Captured & SSG Mullion Cap (Intermediates Only)
WW-338-01	Captured Mullion Cap (Jamb)
SC-1	Spring Clip for DS-1 Door Stop
WW-333-01	Temporary Glazing Retainer for Captured Mullions
SPW-PP-3	Temporary Glazing Retainer for SSG Verticals

# RELIANCE™-SS CURTAIN WALL INSTALLATION MANUAL

## PARTS LIST

### STANDARD FASTENERS

 FS-8	#14 x 1" Phillips Hex Head Horizontals to Verticals & Splice Sleeves to Mullions
 FS-9	#14 x 1-1/2" Hex Head Shear Blocks to Corner Mullions
 FS-15	3/16" x 7/16" Drive Rivet Fastens SC-1 Clip
 FS-56	#10 x 1/2" Phillips Flat Head Attach SSG Mullion Halves
 FS-115	#10 x 1" Phillips Pan Head Horizontal to Corner Shear Block
 FS-119	#10 x 1-3/8" Phillips Flat Head SSG Mullion Adaptor
 FS-202	#8 x 1/2" Phillips Pan Head Attach Mullion Caps
 FS-316	1/4"-20 x 2" HWH Drill Flex Door Jambs
 FS-317	1/8" x 3/4" Headed Roll Pin Face Caps
 FS-320	#10 x 1/2" U-Drive Fastens Mull Caps (Jamb)
 FS-322	#12-14 x 1" Hex Washer Head Drill Flex Attach Splices
 FS-323	#12 x 1" Phillips Flat Head Fastens Steel Through Mullion Face
 FS-325	#12-24 x 1-11/32" Hex Washer Head Drillflex Fastens Pressure Plate to Mullion
 FS-327	#12-14 x 7/8" Hex Washer Head Drillflex Fastens Door Subframe & Corner Glazing Beads