

USE OF GASKETS	
FOR 5/16" (18mm) GLASS: USE ONE THICK GASKET ON EACH SIDE	
FOR 3/8" (10mm) GLASS: USE ONE THIN GASKET ON ONE SIDE AND A THICK GASKET ON THE OTHER SIDE	

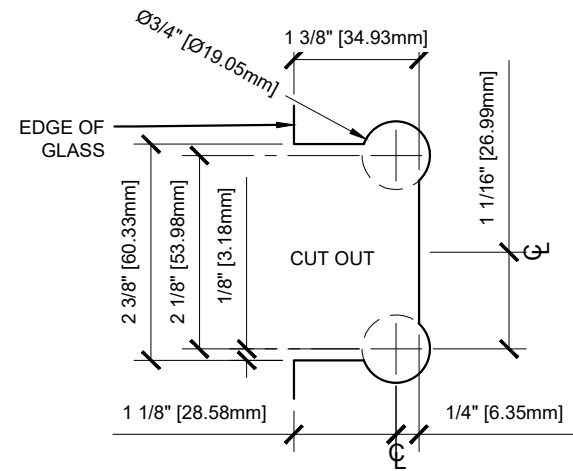

GLASS FABRICATION TEMPLATE

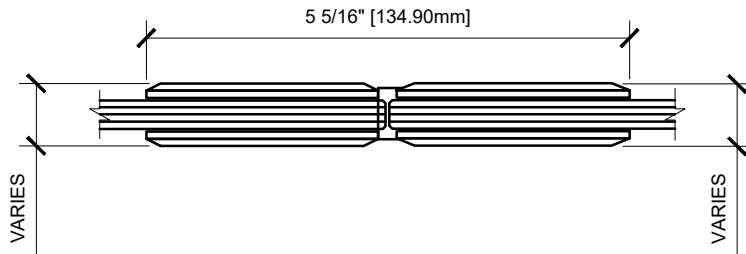
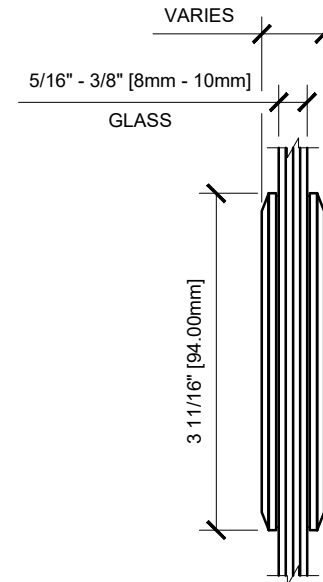
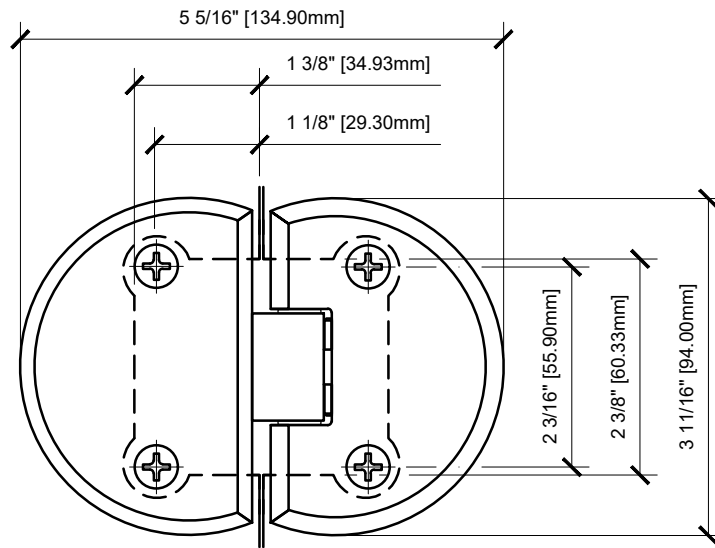

CATALOG NUMBER	FINISH
CLA180CH	POLISHED CHROME
CLA180BN	BRUSHED NICKEL
CLA180GP	GOLD PLATED
CLA180SC	SATIN CHROME
CLA180W	WHITE

CLA180XX - CRL CLASSIQUE SERIES 180 DEGREE GLASS TO GLASS HINGE

DATE: 1/03/19	SCALE: 6" = 1'-0"	DRAWN BY: BRIAN R.
DESCRIPTION: CRL CLA180 CRL CLASSIQUE SERIES 180 DEGREE GLASS TO GLASS HINGE		
C.R. LAURENCE CO. ARCHITECTURAL PRODUCTS 2503 E. Vernon Avenue, Los Angeles, C.A 90058-1897 PH (800)-421-6144 FX: 800-587-7501 www.crlaurence.com		
 A CRH COMPANY		