

USE OF GASKETS

FOR 5/16" (18mm) GLASS: USE ONE THICK GASKET ON EACH SIDE
 FOR 3/8" (10mm) GLASS: USE ONE THIN GASKET ON ONE SIDE AND A THICK GASKET ON THE OTHER SIDE

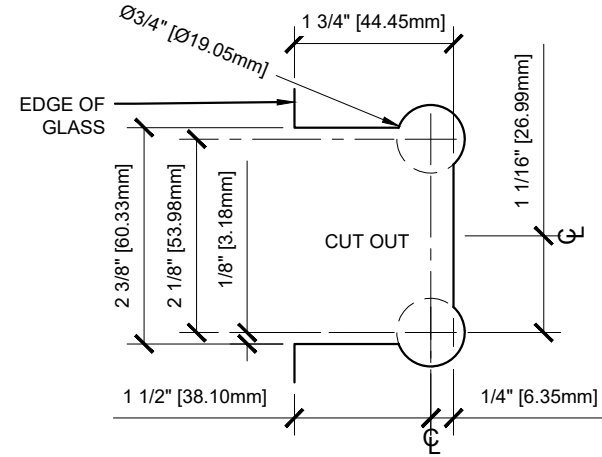

GLASS FABRICATION TEMPLATE

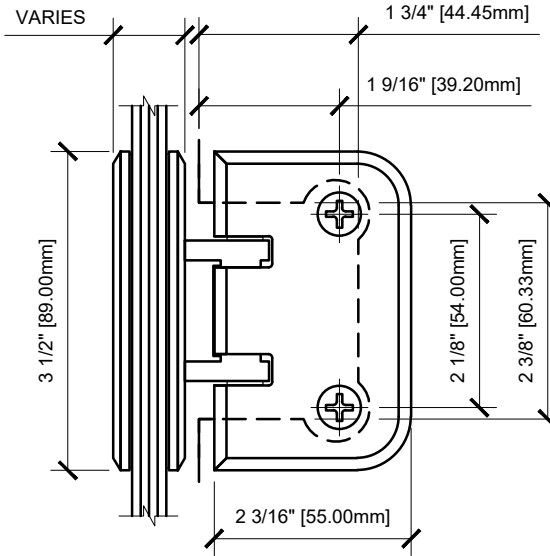
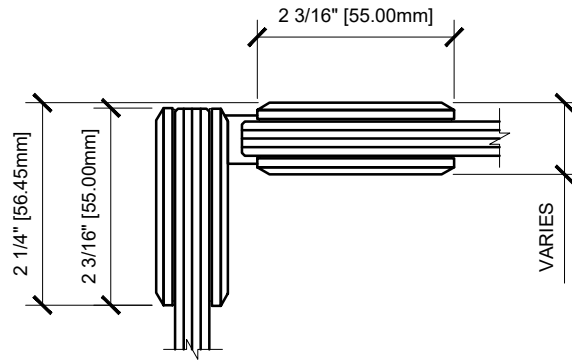
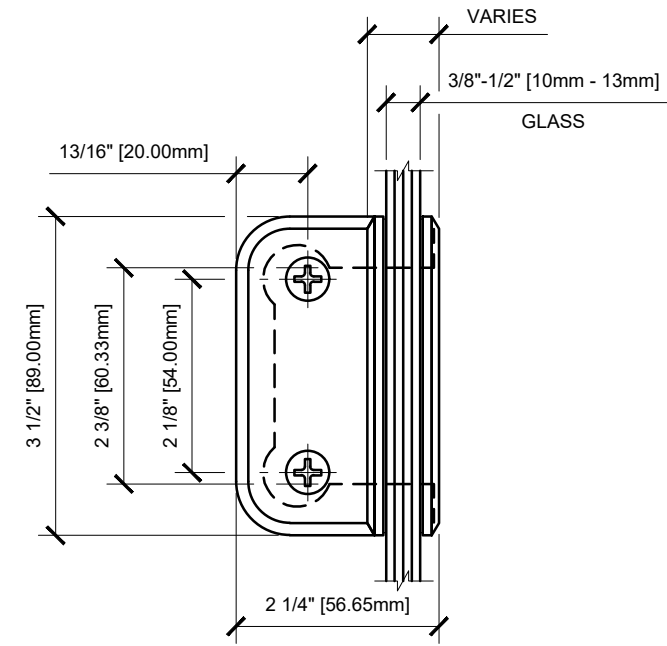

CATALOG NUMBER	FINISH
EST090CH	CHROME
EST090BR	POLISHED BRASS
EST090BN	BRUSHED NICKEL
EST090GP	GOLD PLATED
EST090PN	POLISHED NICKEL
EST090SC	SATIN CHROME
EST090W	WHITE

ESTA090XX - CRL ESTATE 090 SERIES 90 DEGREE GLASS TO GLASS HINGE

DATE: 1/07/19	DESCRIPTION: CRL EST090
SCALE: 6" = 1'-0"	CRL ESTATE SERIES
DRAWN BY: BRIAN R.	90 DEGREE GLASS TO GLASS HINGE
C.R. LAURENCE CO. ARCHITECTURAL PRODUCTS 2503 E. Vernon Avenue, Los Angeles, C.A. 90058-1897 PH (800)-421-6144 FX: 800-587-7301 www.crlaurence.com	
 A CRH COMPANY	