

Cutting Formula for Standard and Heavy Duty Hinge KD Door Kits for 3/8" (10mm), or 1/2" (12mm) Glass

This information applies to Cat. No.'s GEN033, P1N033, and V1E033

Components Description

HINGE JAMB ASSEMBLY - 72" (1829mm), or 78" (1981mm) length
 STRIKE JAMB ASSEMBLY - 72" (1829mm), or 78" (1981mm) length
 BOTTOM DRIP RAIL - 32" (813mm), or 36" (914mm) length
 MOUNTING HARDWARE

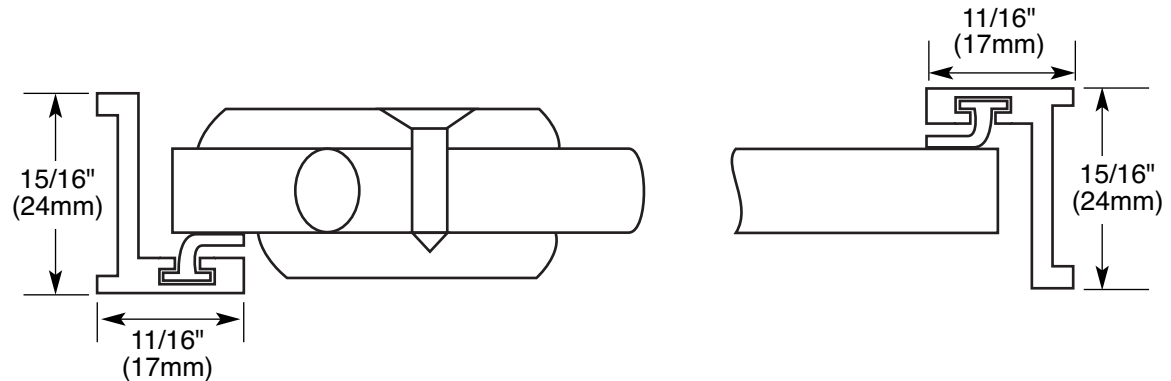

Glass Size Cutting Formula

WIDTH = OVERALL WIDTH OPENING LESS 15/16" (24mm)
 HEIGHT = JAMB HEIGHT LESS 7/16" (11mm) FOR BOTTOM CLEARANCE

Glass Fabrication Information

Hinge Cutouts (Included)

Top Hinge: 8" (203mm) down from the top to the centerline of the hinge cutout.

Bottom Hinge: 7-9/16" (192mm) up from the bottom to the centerline of the hinge cutout.

CAUTION: If the jambs are cut, the fabrication required is altered by the dimension that has been cut off. For Example: The top of the hinge jamb is cut in length by 1-1/4" (32mm). The location of the tip hinge is now 6-3/4" (171mm) down from the top to the center of the hinge cut out.

