

USE OF GASKETS

FOR 1/4" (6mm) GLASS: USE ONE THICK GASKET ON EACH SIDE

FOR 5/16" (8mm) GLASS: USE ONE THIN GASKET ON EACH SIDE

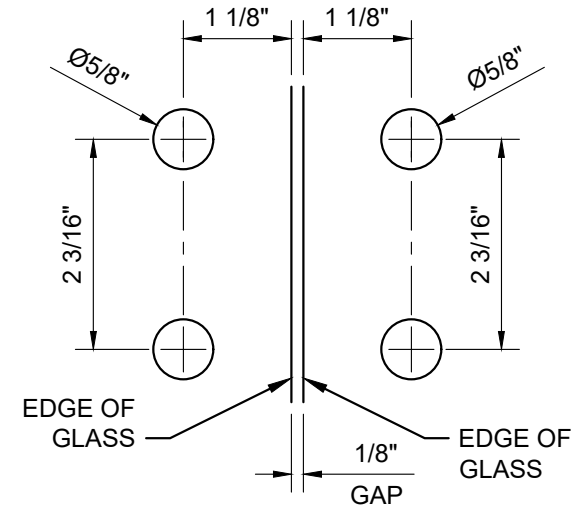
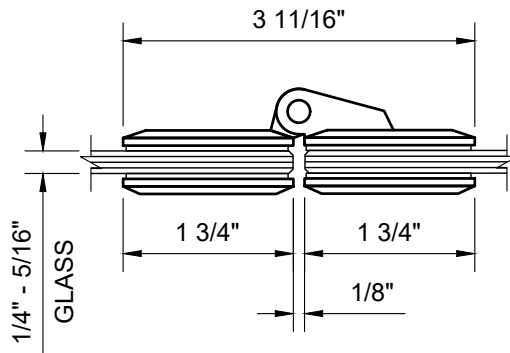

GLASS FABRICATION TEMPLATE

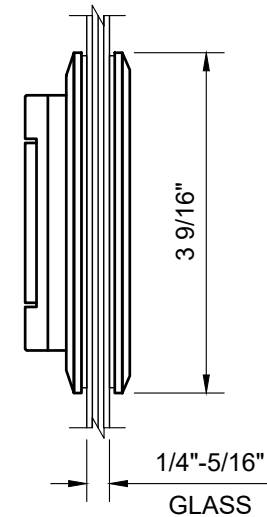
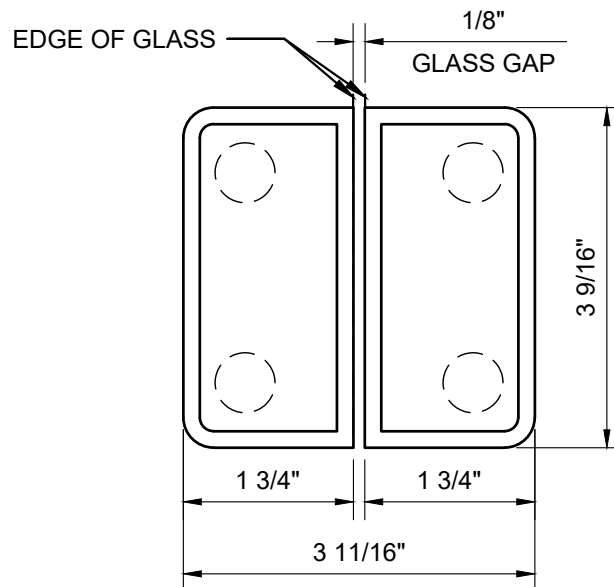

CATALOG NUMBER	FINISH
PET182CH	POLISHED CHROME
PET182BR	POLISHED BRASS
PET182BN	BRUSHED NICKEL
PET182GP	GOLD PLATE
PET182SC	SATIN CHROME

PET182XX - CRL PETITE SERIES 180° IN SWING ONLY GLASS TO GLASS HINGE

DATE: 3/11/19  
 SCALE: 6"=1'-0"  
 DRAWN BY: VM

DESCRIPTION: CRL PETITE SERIES HINGE  
 PET182\_180° SWING IN ONLY  
 GLASS TO GLASS HINGE

C.R. LAURENCE CO. ARCHITECTURAL PRODUCTS  
 2503 E. Vernon Avenue, Los Angeles, CA 90058-1897  
 PH (800)-421-6144 FX: 800-587-7501 www.crlaurence.com

