

DW1800A DW1800DU DW1800P DW1800K DW1800CA

One Fixed / One Sliding Panel, No Screen

Standard Anodized Finishes: (A) Satin (Class II Clear), (DU) Duranodic Bronze
 Specified Custom Finishes: (P) Powder Coat, (K) Kynar, (CA) Custom Anodized
 Factory-Glazed Or Installer-Glazed: Glass Thickness Range 1/4" (6mm) To 5/8" (16mm)

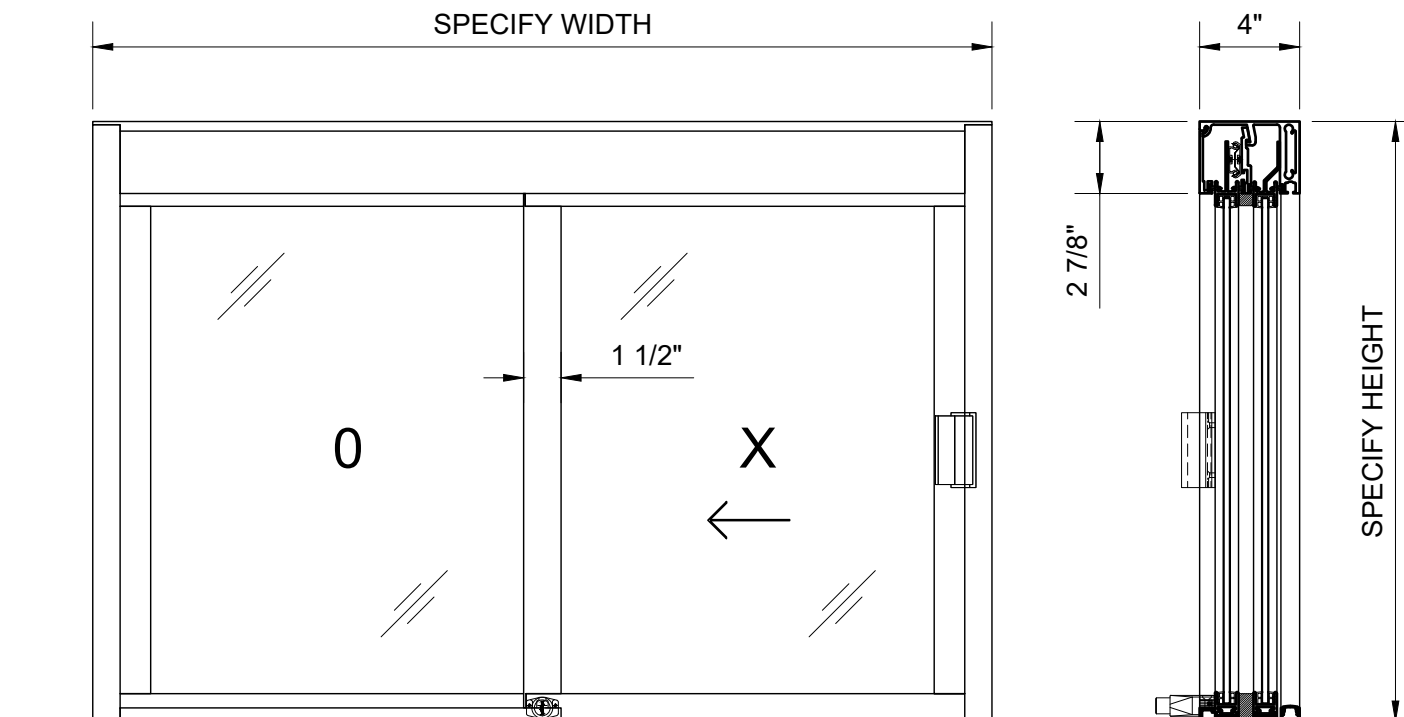

ELEVATION

SECTION

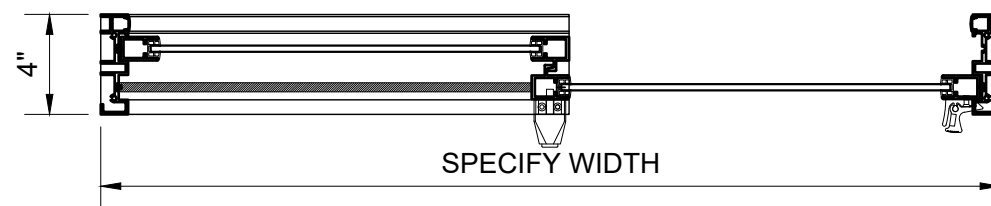

PLAN

ROUGH OPENING TO EXCEED FRAME SIZE
 MINIMUM 1/2" ON WIDTH
 MINIMUM 1/4" ON HEIGHT

APPLICATIONS :

- DRIVE-THRU / WALK-UP SERVICE
- SECURE RECEPTION AREAS
- INFORMATION / SECURITY KIOSKS

DW SERIES CONFIGURATIONS :

MODEL NUMBERS VARY
 OX XO XX OXO OXXO XOX
 (X=SLIDING O=FIXED)

FULL BOTTOM TRACK
 NO TRACK UNDER SLIDING PANEL(S)

FRAME ASSEMBLY MATERIALS :

- | | |
|------------------------------|-------------------------------|
| 6063-T5 EXTRUDED ALUMINUM | STEEL BALL BEARING CARRIER |
| STAINLESS STEEL FASTENERS | POLY-PILE WEATHERSTRIPPING |
| PLASTIC GUIDES, BLOCKS, CAPS | EXTRUDED VINYL GLAZING GASKET |

OPTIONAL ACCESSORIES :

- KEYED LOCK
- STAINLESS STEEL SHELF OR SILL
- WATER DAM STEP
- PLASTIC LAMINATE SHELF
- TRANSOM LITES / SIDE LITES / RETURNS
- FLY FAN SWITCH (SEPARATE AIR CURTAIN)
- BURGLAR BAR (NOT AVAILAIBLE ON XX MODELS)



C.R.LAURENCE CO. TRANSACTION HARDWARE
 2503 E. Vernon Avenue, Los Angeles, C.A 90058-1897
 PHONE: (800)-421-6144 Ext.17760 FAX: 800-587-7000
 transaction@crlaurence.com www.crlaurence.com

CRL DELUXE SLIDING SERVICE WINDOW

MANUAL OPEN / MANUAL CLOSE

PAGE: 1.1

REV.:	11/23/22
DATE:	08/06/19
SCALE:	1-1/2"=1'-0"
DRAWN BY:	RPD

CRL DELUXE SLIDING SERVICE WINDOW KEYED LOCK OPTION AND STANDARD FEATURES

DW1800 (OX OR XO)
(NO SCREEN)

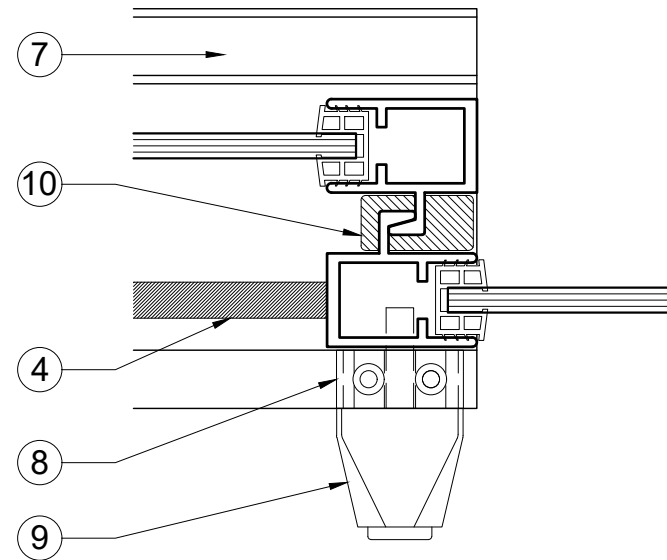

* KEYED LOCK PLAN

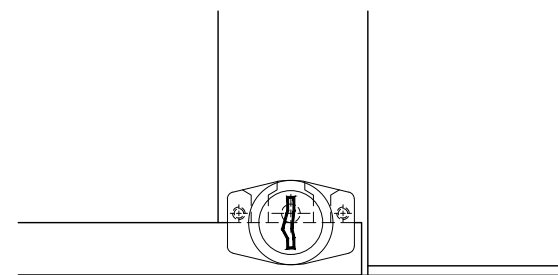

* KEYED LOCK ELEVATION

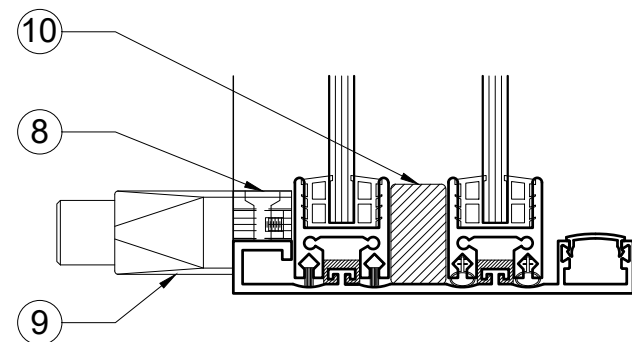

* KEYED LOCK SECTION

* KEY LOCK MUST BE SPECIFIED

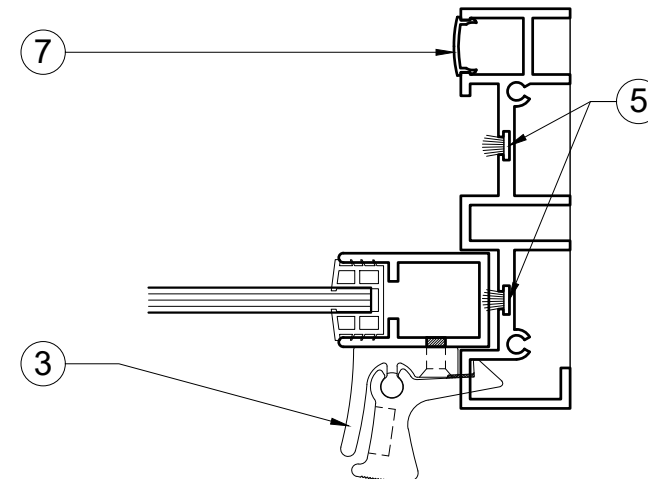

PLAN @ HANDLE

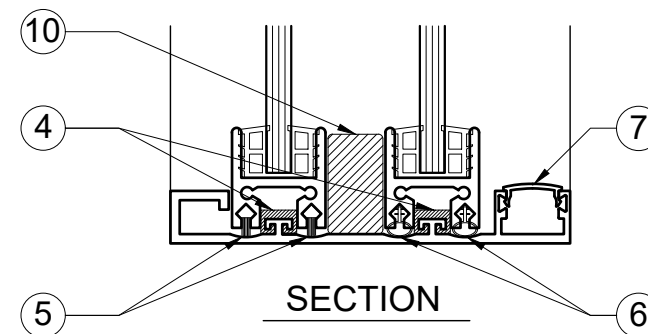
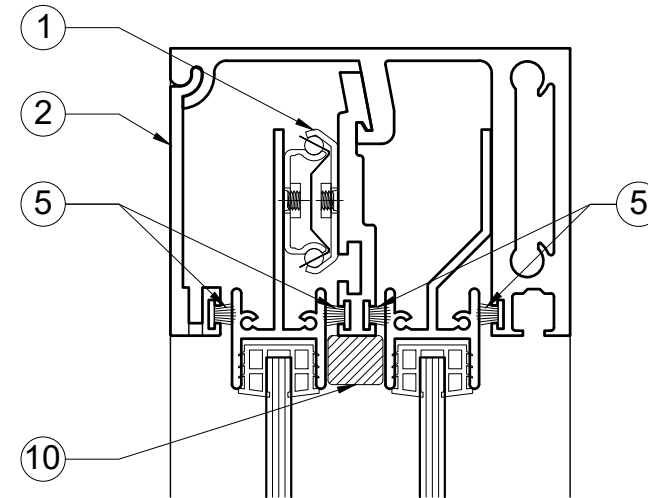

- | | |
|-------------------------|---------------------------------------------|
| 1. HEAVY DUTY CARRIER | 7. SCREEN RACE CAP |
| 2. HEADER ACCESS PANEL | 8. ADAPTER BLOCK |
| 3. SELF-LATCHING HANDLE | 9. CRL CAT # 0911BCKA
KEYED PLUNGER LOCK |
| 4. VINYL GUIDES | 10. FILLER BLOCKS |
| 5. WEATHERSTRIPPING | |
| 6. BULB SEAL | |

* LOCK ADAPTERS VARY PER MODEL



C.R.LAURENCE CO. TRANSACTION HARDWARE
2503 E. Vernon Avenue, Los Angeles, C.A 90058-1897
PHONE: (800)-421-6144 Ex.17760 FAX: 800-587-1776
transaction@crlaurence.com www.crlaurence.com

CRL DELUXE SLIDING SERVICE WINDOW

MANUAL OPEN / MANUAL CLOSE

PAGE:
1.2

REV.:	11/23/22
DATE:	08/06/19
SCALE:	6"=1'-0"
DRAWN BY:	RPD

DW2000A DW2000DU DW2000P DW2000K DW2000CA

One Fixed / One Sliding Panel, With Screen

Standard Anodized Finishes: (A) Satin (Class II Clear), (DU) DuraNodic Bronze
 Specified Custom Finishes: (P) Powder Coat, (K) Kynar, (CA) Custom Anodized
 Factory-Glazed Or Installer-Glazed: Glass Thickness Range 1/4" (6mm) To 5/8" (16mm)

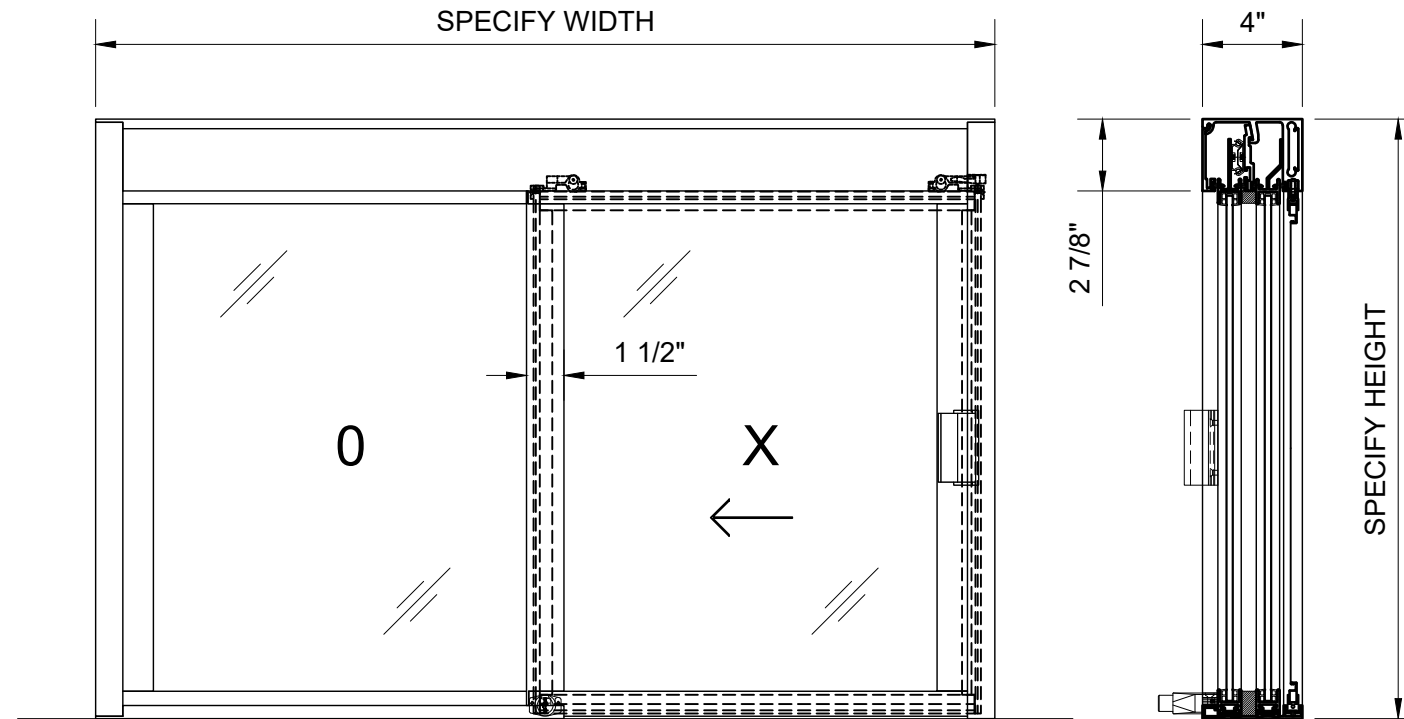

ELEVATION

SECTION

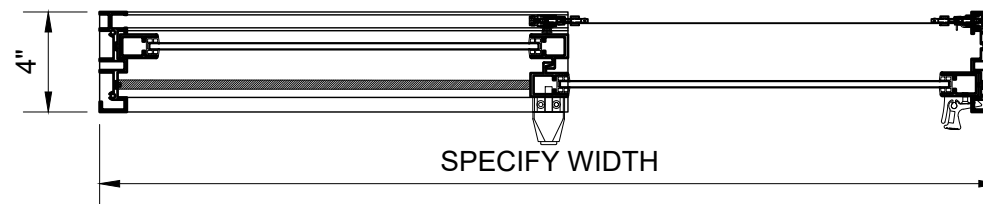

PLAN

ROUGH OPENING TO EXCEED FRAME SIZE
 MINIMUM 1/2" ON WIDTH
 MINIMUM 1/4" ON HEIGHT

APPLICATIONS :

- DRIVE-THRU / WALK-UP SERVICE
- SECURE RECEPTION AREAS
- INFORMATION / SECURITY KIOSKS

DW SERIES CONFIGURATIONS :

MODEL NUMBERS VARY
 OX XO XX OXO OXOX
 (X=SLIDING O=FIXED)

FULL BOTTOM TRACK
 NO TRACK UNDER SLIDING PANEL(S)

FRAME ASSEMBLY MATERIALS :

- | | |
|------------------------------|-------------------------------|
| 6063-T5 EXTRUDED ALUMINUM | STEEL BALL BEARING CARRIER |
| STAINLESS STEEL FASTENERS | POLY-PILE WEATHERSTRIPPING |
| PLASTIC GUIDES, BLOCKS, CAPS | EXTRUDED VINYL GLAZING GASKET |

OPTIONAL ACCESSORIES :

- KEYED LOCK
- STAINLESS STEEL SHELF OR SILL
- WATER DAM STEP
- PLASTIC LAMINATE SHELF
- TRANSOM LITES / SIDE LITES / RETURNS
- FLY FAN SWITCH (SEPARATE AIR CURTAIN)
- BURGLAR BAR (NOT AVAILABLE ON XX MODELS)

REV.:	11/23/22
DATE:	08/06/19
SCALE:	1-1/2"=1'-0"
DRAWN BY:	RPD

**CRL DELUXE SLIDING SERVICE WINDOW
KEYED LOCK OPTION AND STANDARD FEATURES
DW2000 (OX OR XO)
(WITH SCREEN)**

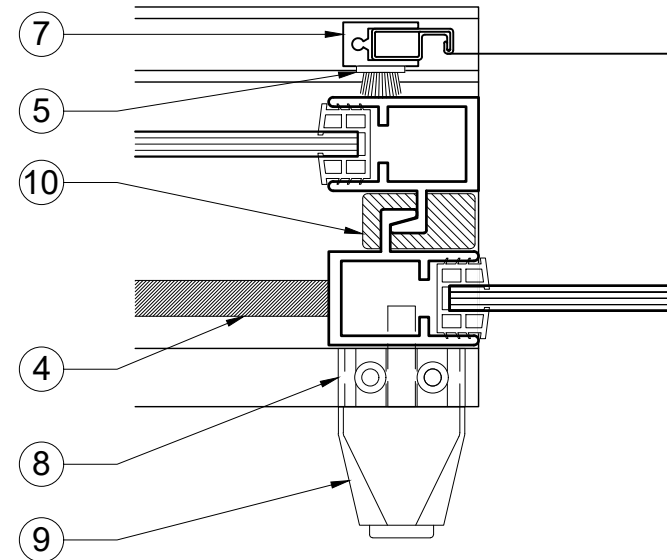

*** KEYED LOCK PLAN**

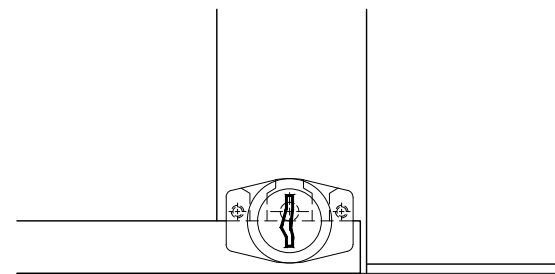

*** KEYED LOCK ELEVATION**

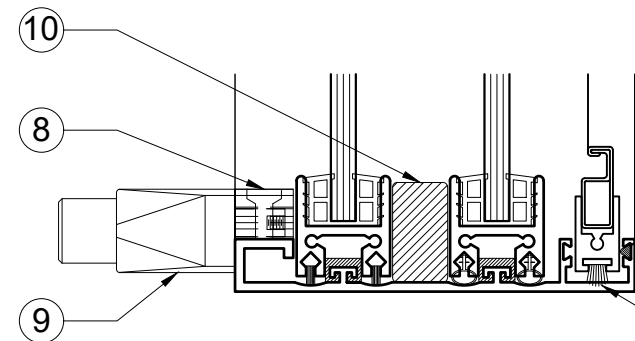

*** KEYED LOCK SECTION**

* KEY LOCK MUST BE SPECIFIED

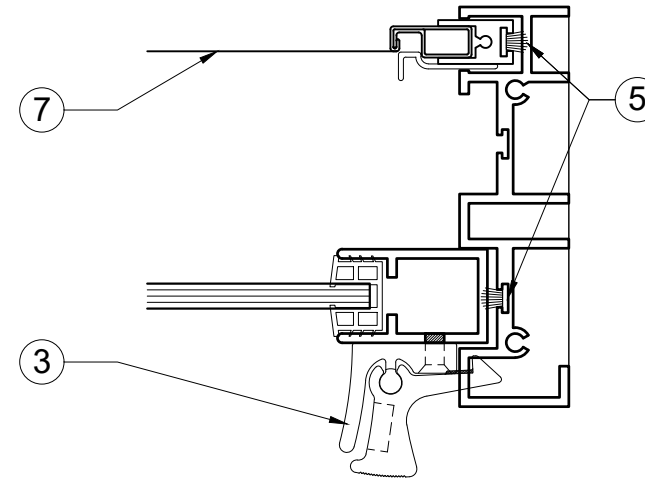

PLAN @ HANDLE

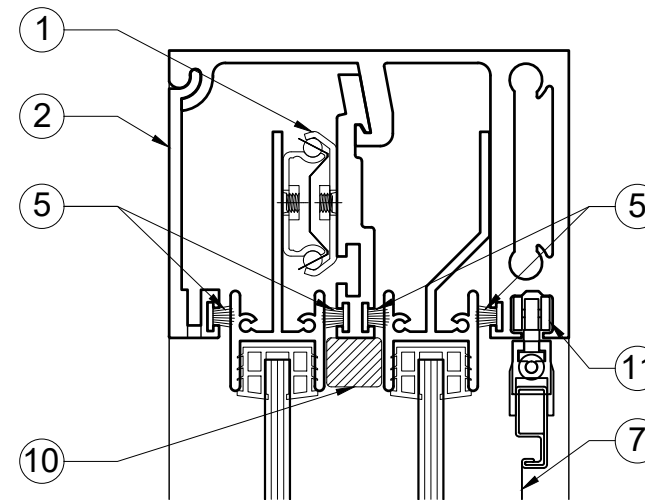

SECTION

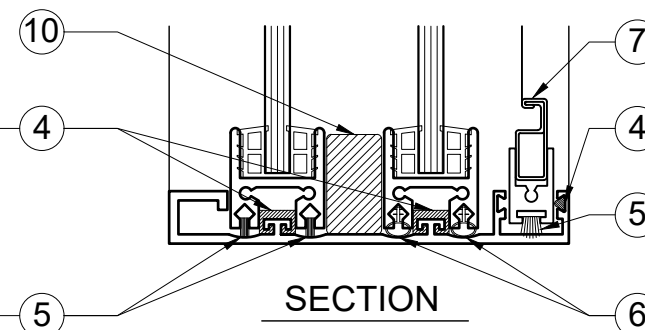

- | | |
|-------------------------|---------------------------------------------|
| 1. HEAVY DUTY CARRIER | 7. SCREEN / FRAME |
| 2. HEADER ACCESS PANEL | 8. ADAPTER BLOCK |
| 3. SELF-LATCHING HANDLE | 9. CRL CAT # 0911BCKA
KEYED PLUNGER LOCK |
| 4. VINYL GUIDES | 10. FILLER BLOCKS |
| 5. WEATHERSTRIPPING | 11. SCREEN ROLLER |
| 6. BULB SEAL | |

* LOCK ADAPTERS VARY PER MODEL



C.R.LAURENCE CO. TRANSACTION HARDWARE
2503 E. Vernon Avenue, Los Angeles, C.A 90058-1897
PHONE: (800)-421-6144 Ext.17760 FAX: 800-587-7661
transaction@crlaurence.com www.crlaurence.com

CRL DELUXE SLIDING SERVICE WINDOW

MANUAL OPEN / MANUAL CLOSE

PAGE:

2.2

REV.:	11/23/22
DATE:	08/06/19
SCALE:	6"=1'-0"
DRAWN BY:	RPD

DW2600A DW2600DU DW2600P DW2600K DW2600CA

Two Fixed / One Sliding Panel, No Screen

Standard Anodized Finishes: (A) Satin (Class II Clear), (DU) Duranodic Bronze
 Specified Custom Finishes: (P) Powder Coat, (K) Kynar, (CA) Custom Anodized
 Factory-Glazed Or Installer-Glazed: Glass Thickness Range 1/4" (6mm) To 5/8" (16mm)

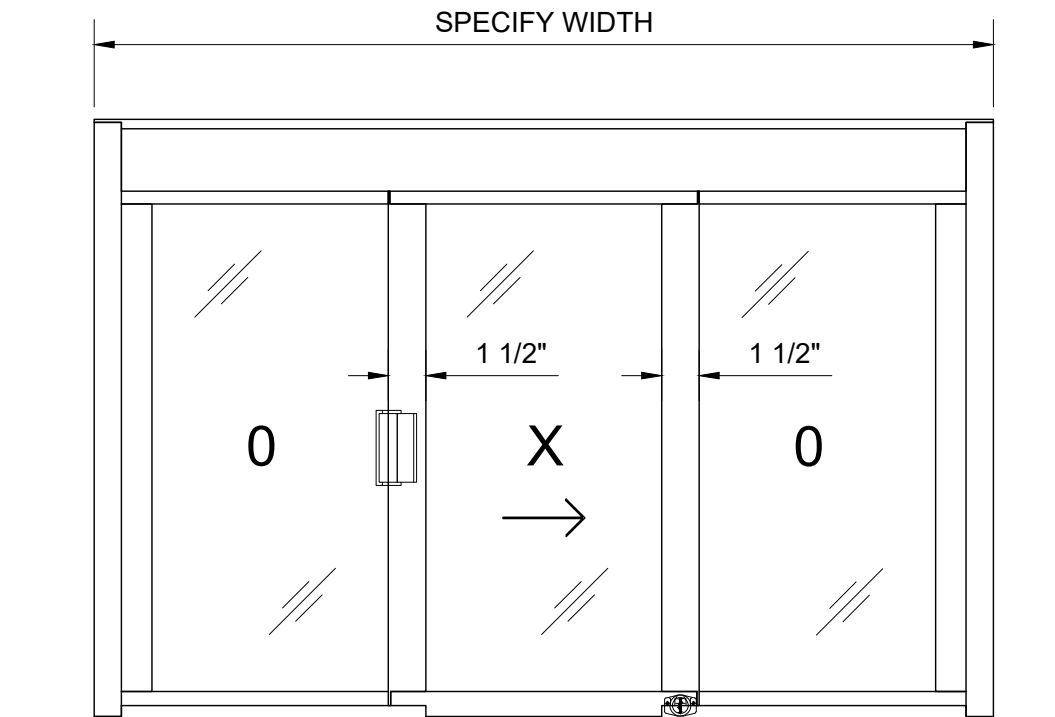

ELEVATION

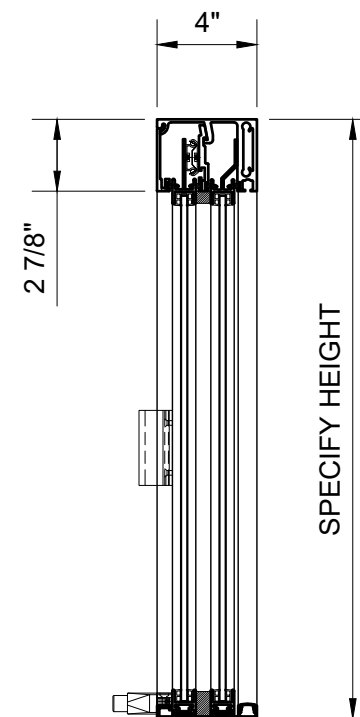

SECTION

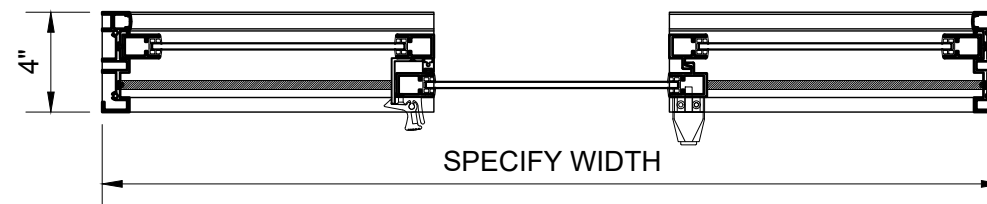

PLAN

ROUGH OPENING TO EXCEED FRAME SIZE
 MINIMUM 1/2" ON WIDTH
 MINIMUM 1/4" ON HEIGHT

APPLICATIONS :

- DRIVE-THRU / WALK-UP SERVICE
- SECURE RECEPTION AREAS
- INFORMATION / SECURITY KIOSKS

DW SERIES CONFIGURATIONS :

MODEL NUMBERS VARY
 OX XO XX OXO OXOX
 (X=SLIDING O=FIXED)

FULL BOTTOM TRACK
 NO TRACK UNDER SLIDING PANEL(S)

FRAME ASSEMBLY MATERIALS :

- | | |
|------------------------------|-------------------------------|
| 6063-T5 EXTRUDED ALUMINUM | STEEL BALL BEARING CARRIER |
| STAINLESS STEEL FASTENERS | POLY-PILE WEATHERSTRIPPING |
| PLASTIC GUIDES, BLOCKS, CAPS | EXTRUDED VINYL GLAZING GASKET |

OPTIONAL ACCESSORIES :

- KEYED LOCK
- STAINLESS STEEL SHELF OR SILL
- WATER DAM STEP
- PLASTIC LAMINATE SHELF
- TRANSOM LITES / SIDE LITES / RETURNS
- FLY FAN SWITCH (SEPARATE AIR CURTAIN)
- BURGLAR BAR (NOT AVAILABLE ON XX MODELS)



C.R.LAURENCE CO. TRANSACTION HARDWARE
 2503 E. Vernon Avenue, Los Angeles, C.A 90058-1897
 PHONE: (800)-421-6144 Ex.17760 FAX: 800-587-7400
 transaction@crlaurence.com www.crlaurence.com

CRL DELUXE SLIDING SERVICE WINDOW

MANUAL OPEN / MANUAL CLOSE

PAGE: 3.1

REV.:	11/23/22
DATE:	08/06/19
SCALE:	1-1/2"=1'-0"
DRAWN BY:	RPD

CRL DELUXE SLIDING SERVICE WINDOW KEYED LOCK OPTION AND STANDARD FEATURES

DW2600 (OXO)
(NO SCREEN)

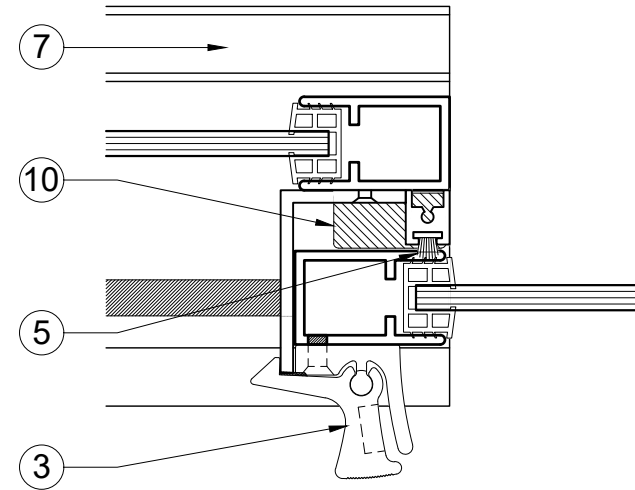

KEYED LOCK PLAN

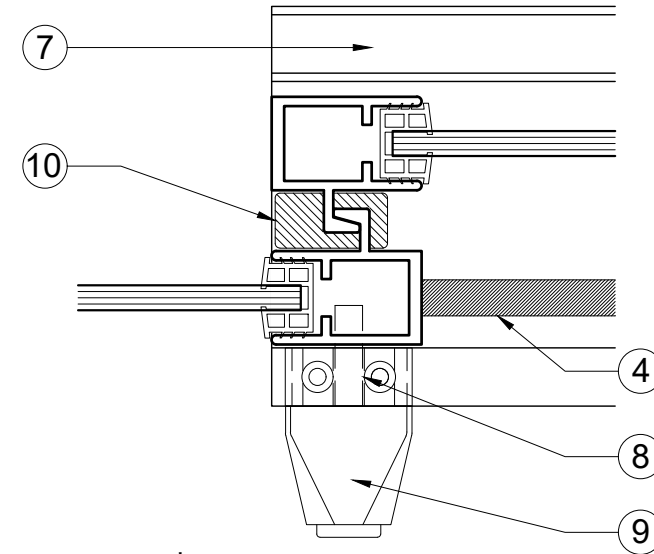

* KEYED LOCK PLAN

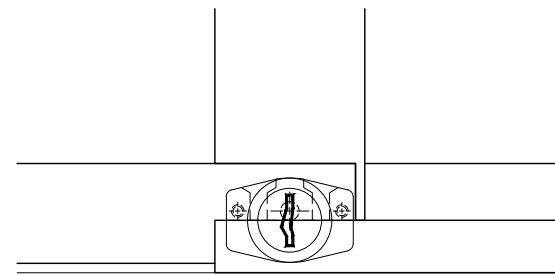

* KEYED LOCK ELEVATION

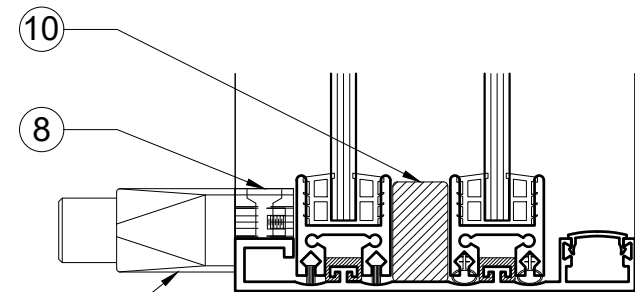

* KEYED LOCK SECTION

* KEY LOCK MUST BE SPECIFIED

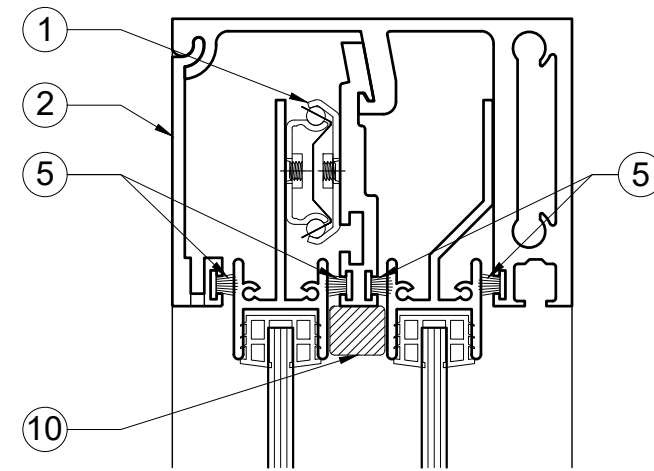

SECTION

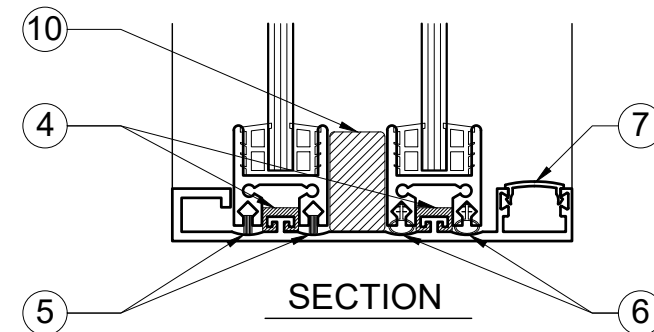

- | | |
|-------------------------|---------------------------------------------|
| 1. HEAVY DUTY CARRIER | 7. SCREEN RACE CAP |
| 2. HEADER ACCESS PANEL | 8. ADAPTER BLOCK |
| 3. SELF-LATCHING HANDLE | 9. CRL CAT # 0911BCKA
KEYED PLUNGER LOCK |
| 4. VINYL GUIDES | 10. FILLER BLOCKS |
| 5. WEATHERSTRIPPING | |
| 6. BULB SEAL | |

* LOCK ADAPTERS VARY PER MODEL



C.R.LAURENCE CO. TRANSACTION HARDWARE
2503 E. Vernon Avenue, Los Angeles, C.A 90058-1897
PHONE: (800)-421-6144 Ex.17760 FAX: 800-587-7100
transaction@crlaurence.com www.crlaurence.com

CRL DELUXE SLIDING SERVICE WINDOW

MANUAL OPEN / MANUAL CLOSE

PAGE:
3.2

REV.:	11/23/22
DATE:	08/06/19
SCALE:	6"=1'-0"
DRAWN BY:	RPD

DW2800A DW2800DU DW2800P DW2800K DW2800CA

Two Fixed / One Sliding Panel, With Screen

Standard Anodized Finishes: (A) Satin (Class II Clear), (DU) Duranodic Bronze
 Specified Custom Finishes: (P) Powder Coat, (K) Kynar, (CA) Custom Anodized
 Factory-Glazed Or Installer-Glazed: Glass Thickness Range 1/4" (6mm) To 5/8" (16mm)

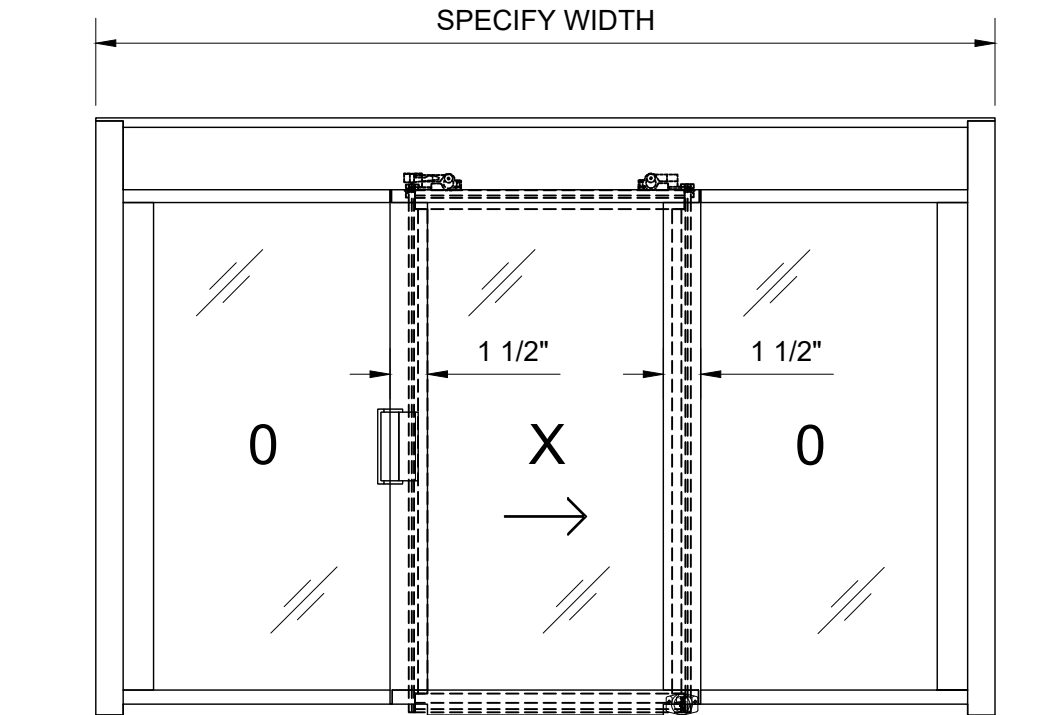

ELEVATION

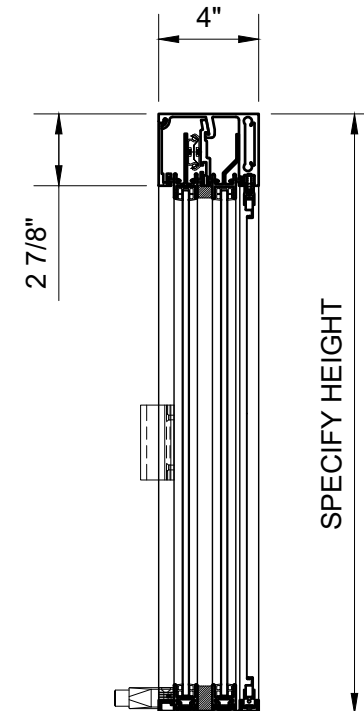

SECTION

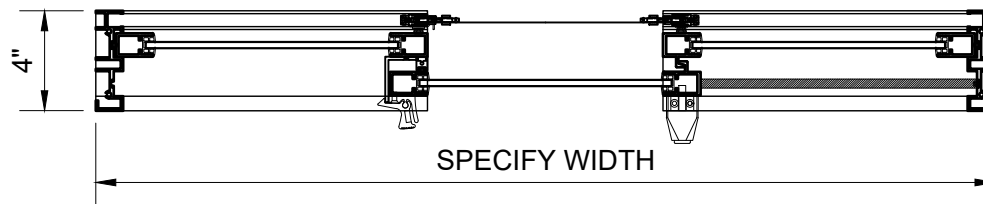

PLAN

ROUGH OPENING TO EXCEED FRAME SIZE
 MINIMUM 1/2" ON WIDTH
 MINIMUM 1/4" ON HEIGHT

APPLICATIONS :

- DRIVE-THRU / WALK-UP SERVICE
- SECURE RECEPTION AREAS
- INFORMATION / SECURITY KIOSKS

DW SERIES CONFIGURATIONS :

MODEL NUMBERS VARY
 OX XO XX OXO OXOX
 (X=SLIDING O=FIXED)

FULL BOTTOM TRACK
 NO TRACK UNDER SLIDING PANEL(S)

FRAME ASSEMBLY MATERIALS :

- | | |
|------------------------------|-------------------------------|
| 6063-T5 EXTRUDED ALUMINUM | STEEL BALL BEARING CARRIER |
| STAINLESS STEEL FASTENERS | POLY-PILE WEATHERSTRIPPING |
| PLASTIC GUIDES, BLOCKS, CAPS | EXTRUDED VINYL GLAZING GASKET |

OPTIONAL ACCESSORIES :

- KEYED LOCK
- STAINLESS STEEL SHELF OR SILL
- WATER DAM STEP
- PLASTIC LAMINATE SHELF
- TRANSOM LITES / SIDE LITES / RETURNS
- FLY FAN SWITCH (SEPARATE AIR CURTAIN)
- BURGLAR BAR (NOT AVAILABLE ON XX MODELS)



C.R.LAURENCE CO. TRANSACTION HARDWARE
 2503 E. Vernon Avenue, Los Angeles, C.A 90058-1897
 PHONE: (800)-421-6144 Ex.17760 FAX: 800-587-7400
 transaction@crlaurence.com www.crlaurence.com

CRL DELUXE SLIDING SERVICE WINDOW

MANUAL OPEN / MANUAL CLOSE

PAGE: 4.1

REV.:	11/23/22
DATE:	08/06/19
SCALE:	1-1/2"=1'-0"
DRAWN BY:	RPD

CRL DELUXE SLIDING SERVICE WINDOW

KEYED LOCK OPTION AND STANDARD FEATURES

DW2800 (OXO)
(WITH SCREEN)

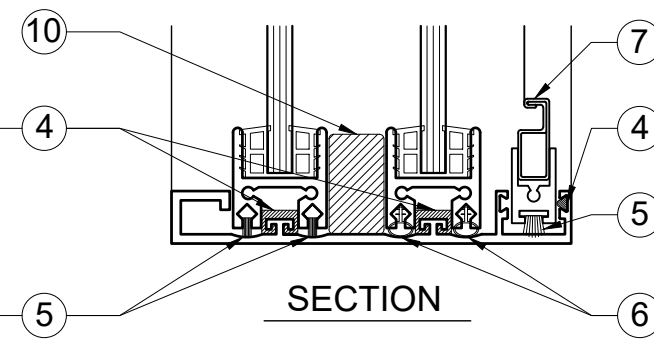
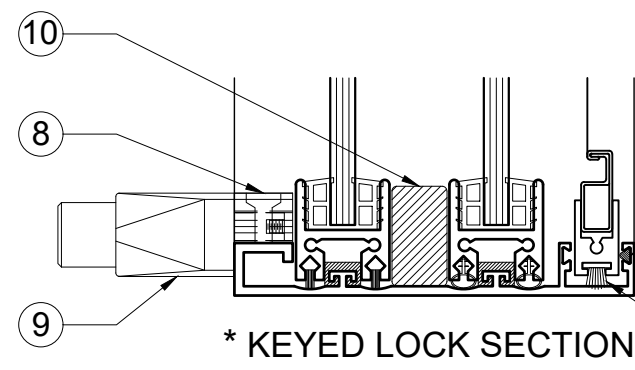
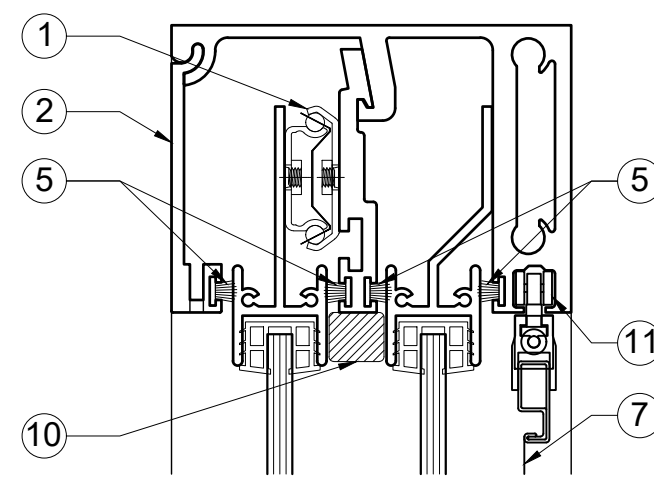
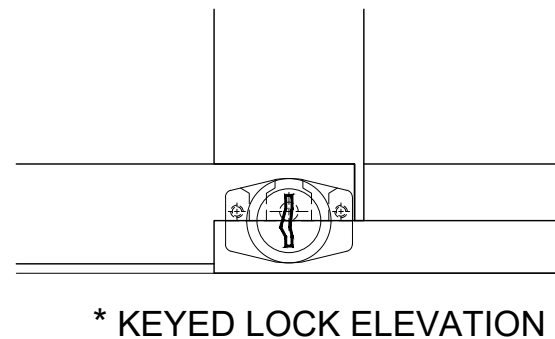
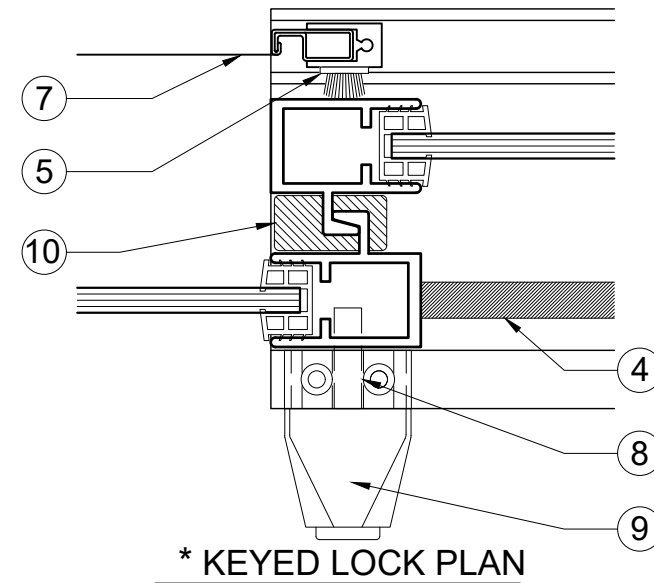
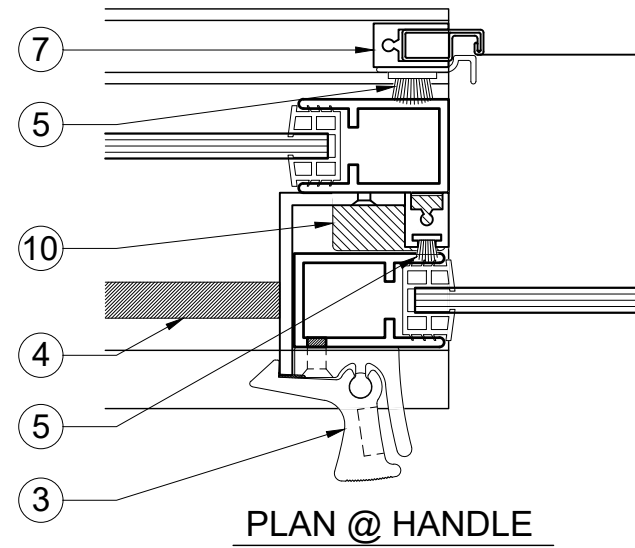

* KEY LOCK MUST BE SPECIFIED

- | | |
|-------------------------|---------------------------------------------|
| 1. HEAVY DUTY CARRIER | 7. SCREEN / FRAME |
| 2. HEADER ACCESS PANEL | 8. ADAPTER BLOCK |
| 3. SELF-LATCHING HANDLE | 9. CRL CAT # 0911BCKA
KEYED PLUNGER LOCK |
| 4. VINYL GUIDES | 10. FILLER BLOCKS |
| 5. WEATHERSTRIPPING | 11. SCREEN ROLLER |
| 6. BULB SEAL | |

* LOCK ADAPTERS VARY PER MODEL

DW3400A DW3400DU DW3400P DW3400K DW3400CA

Two Fixed / Two Sliding Panels, No Screens

Standard Anodized Finishes: (A) Satin (Class II Clear), (DU) Duranodic Bronze
 Specified Custom Finishes: (P) Powder Coat, (K) Kynar, (CA) Custom Anodized
 Factory-Glazed Or Installer-Glazed: Glass Thickness Range 1/4" (6mm) To 5/8" (16mm)

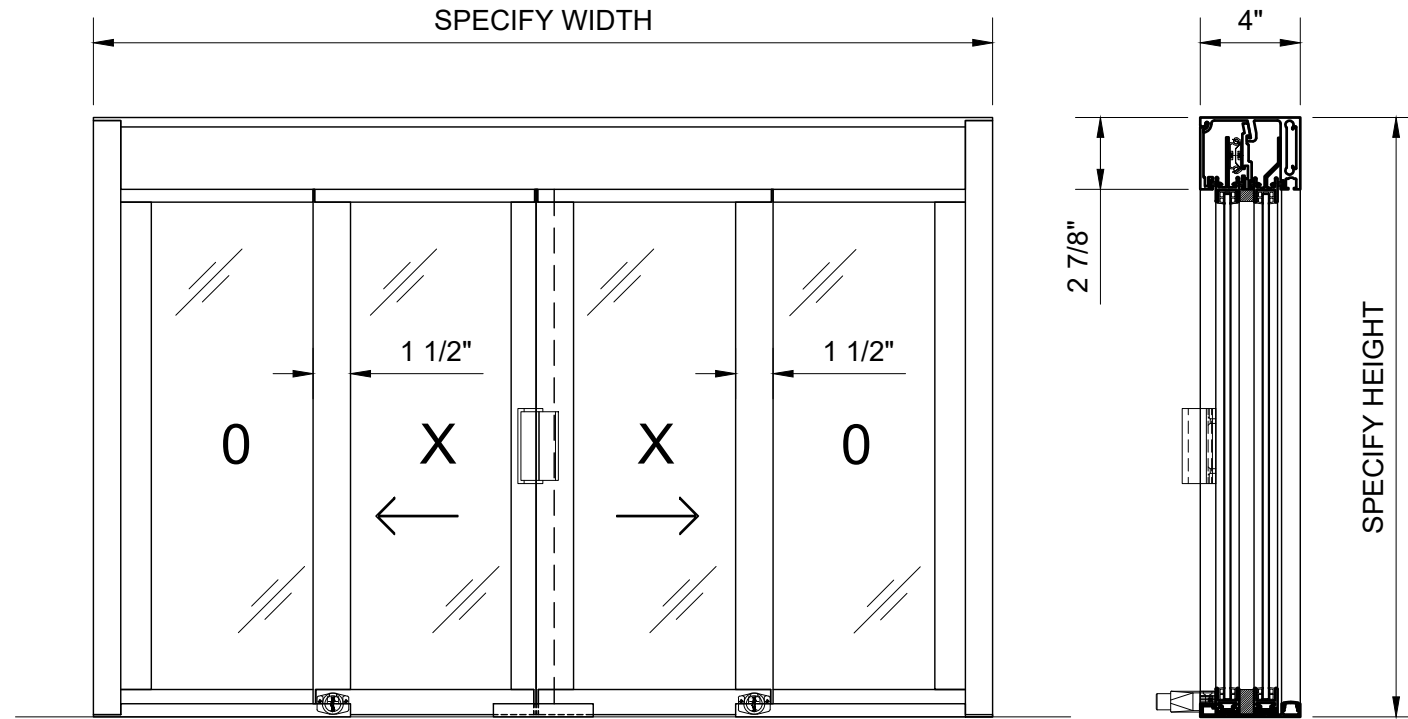

ELEVATION

SECTION

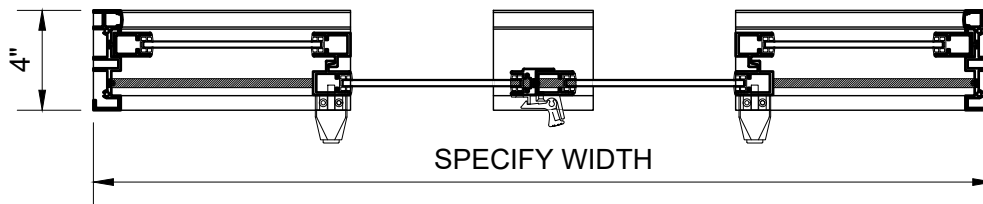

PLAN

ROUGH OPENING TO EXCEED FRAME SIZE
 MINIMUM 1/2" ON WIDTH
 MINIMUM 1/4" ON HEIGHT

APPLICATIONS :

- DRIVE-THRU / WALK-UP SERVICE
- SECURE RECEPTION AREAS
- INFORMATION / SECURITY KIOSKS

AVAILABLE CONFIGURATIONS :

MODEL NUMBERS VARY
 OX XO XX OXO OXXO XO
 (X=SLIDING O=FIXED)

FULL BOTTOM TRACK
 NO TRACK UNDER SLIDING PANEL(S)

FRAME ASSEMBLY MATERIALS :

- | | |
|------------------------------|-------------------------------|
| 6063-T5 EXTRUDED ALUMINUM | STEEL BALL BEARING CARRIER |
| STAINLESS STEEL FASTENERS | POLY-PILE WEATHERSTRIPPING |
| PLASTIC GUIDES, BLOCKS, CAPS | EXTRUDED VINYL GLAZING GASKET |

OPTIONAL ACCESSORIES :

- KEYED LOCK
- STAINLESS STEEL SHELF OR SILL
- WATER DAM STEP
- PLASTIC LAMINATE SHELF
- TRANSOM LITES / SIDE LITES / RETURNS
- FLY FAN SWITCH (SEPARATE AIR CURTAIN)
- BURGLAR BAR (NOT AVAILABLE ON XX MODELS)

REV.: 11/23/22

DATE: 08/06/19

SCALE: 1-1/2"=1'-0"

DRAWN BY: RPD



C.R.LAURENCE CO. TRANSACTION HARDWARE
 2503 E. Vernon Avenue, Los Angeles, C.A 90058-1897
 PHONE: (800)-421-6144 Ex.17760 FAX: 800-587-7400
 transaction@crlaurence.com www.crlaurence.com

CRL DELUXE SLIDING SERVICE WINDOW

MANUAL OPEN / MANUAL CLOSE

PAGE: 5.1

CRL DELUXE SLIDING SERVICE WINDOW

KEYED LOCK OPTION AND STANDARD FEATURES

DW3400 (OXXO)

(NO SCREENS)

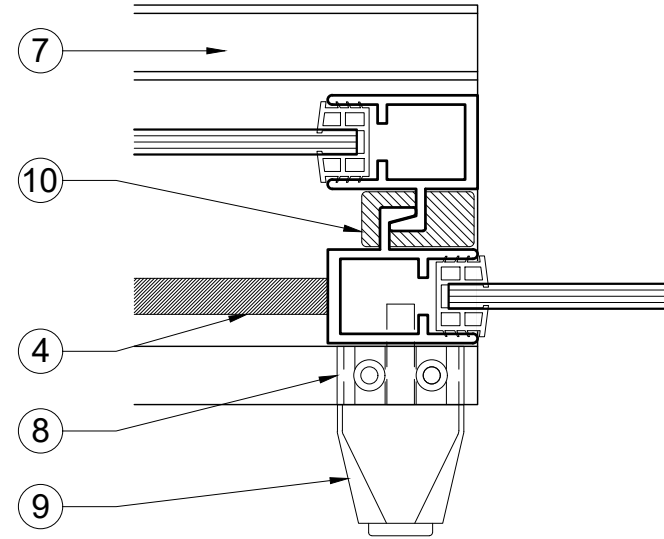

* KEYED LOCK PLAN

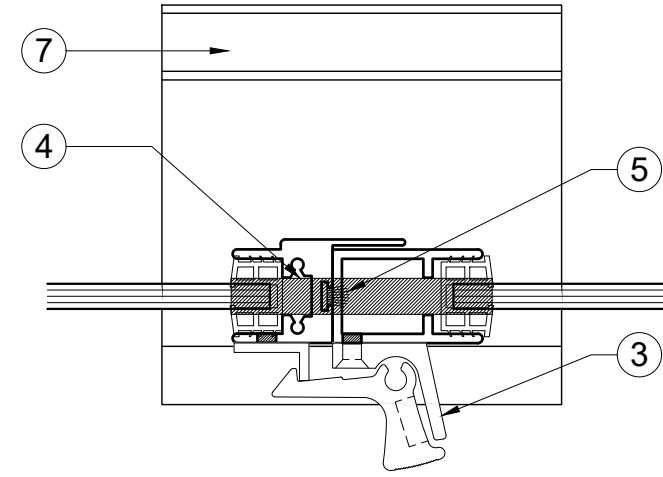

MEETING STILE PLAN

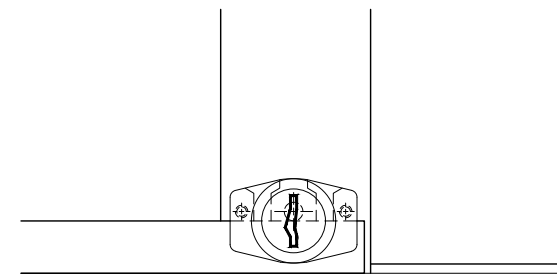

* KEYED LOCK ELEVATION

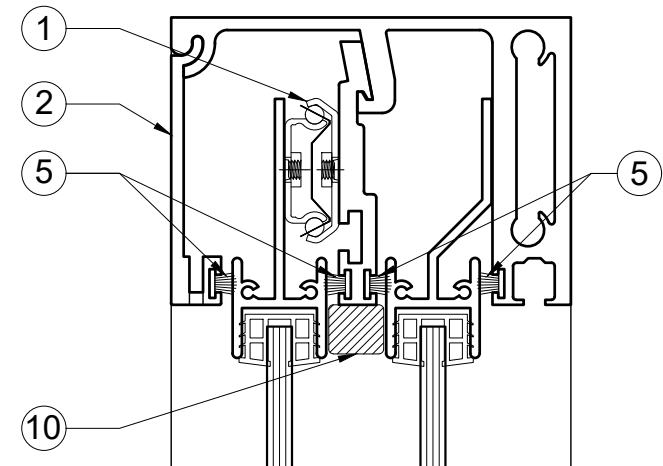

SECTION

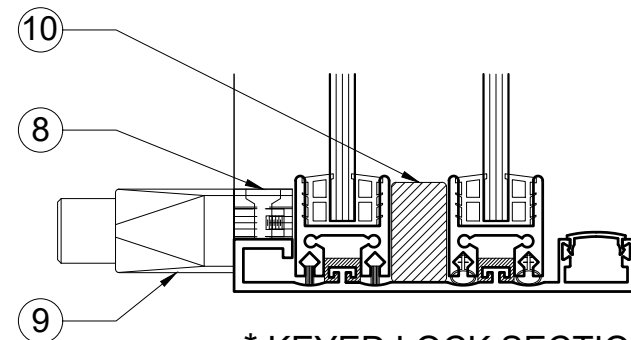

* KEYED LOCK SECTION

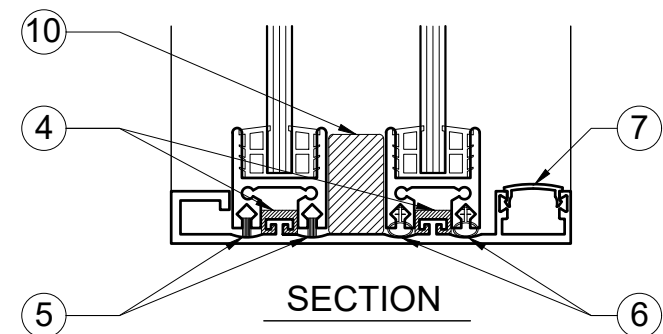

* KEY LOCK MUST BE SPECIFIED

- | | |
|-------------------------|---------------------------------------------|
| 1. HEAVY DUTY CARRIER | 7. SCREEN RACE CAP |
| 2. HEADER ACCESS PANEL | 8. ADAPTER BLOCK |
| 3. SELF-LATCHING HANDLE | 9. CRL CAT # 0911BCKA
KEYED PLUNGER LOCK |
| 4. VINYL GUIDES | 10. FILLER BLOCKS |
| 5. WEATHERSTRIPPING | |
| 6. BULB SEAL | |

* LOCK ADAPTERS VARY PER MODEL



C.R.LAURENCE CO. TRANSACTION HARDWARE
2503 E. Vernon Avenue, Los Angeles, C.A 90058-1897
PHONE: (800)-421-6144 Ex.17760 FAX: 800-587-7100
transaction@crlaurence.com www.crlaurence.com

CRL DELUXE SLIDING SERVICE WINDOW

MANUAL OPEN / MANUAL CLOSE

PAGE:

5.2

REV.:	11/23/22
DATE:	08/06/19
SCALE:	6"=1'-0"
DRAWN BY:	RPD

DW3600A DW3600DU DW3600P DW3600K DW3600CA

Two Fixed / Two Sliding Panels, With Screens

Standard Anodized Finishes: (A) Satin (Class II Clear), (DU) Duranodic Bronze
 Specified Custom Finishes: (P) Powder Coat, (K) Kynar, (CA) Custom Anodized
 Factory-Glazed Or Installer-Glazed: Glass Thickness Range 1/4" (6mm) To 5/8" (16mm)

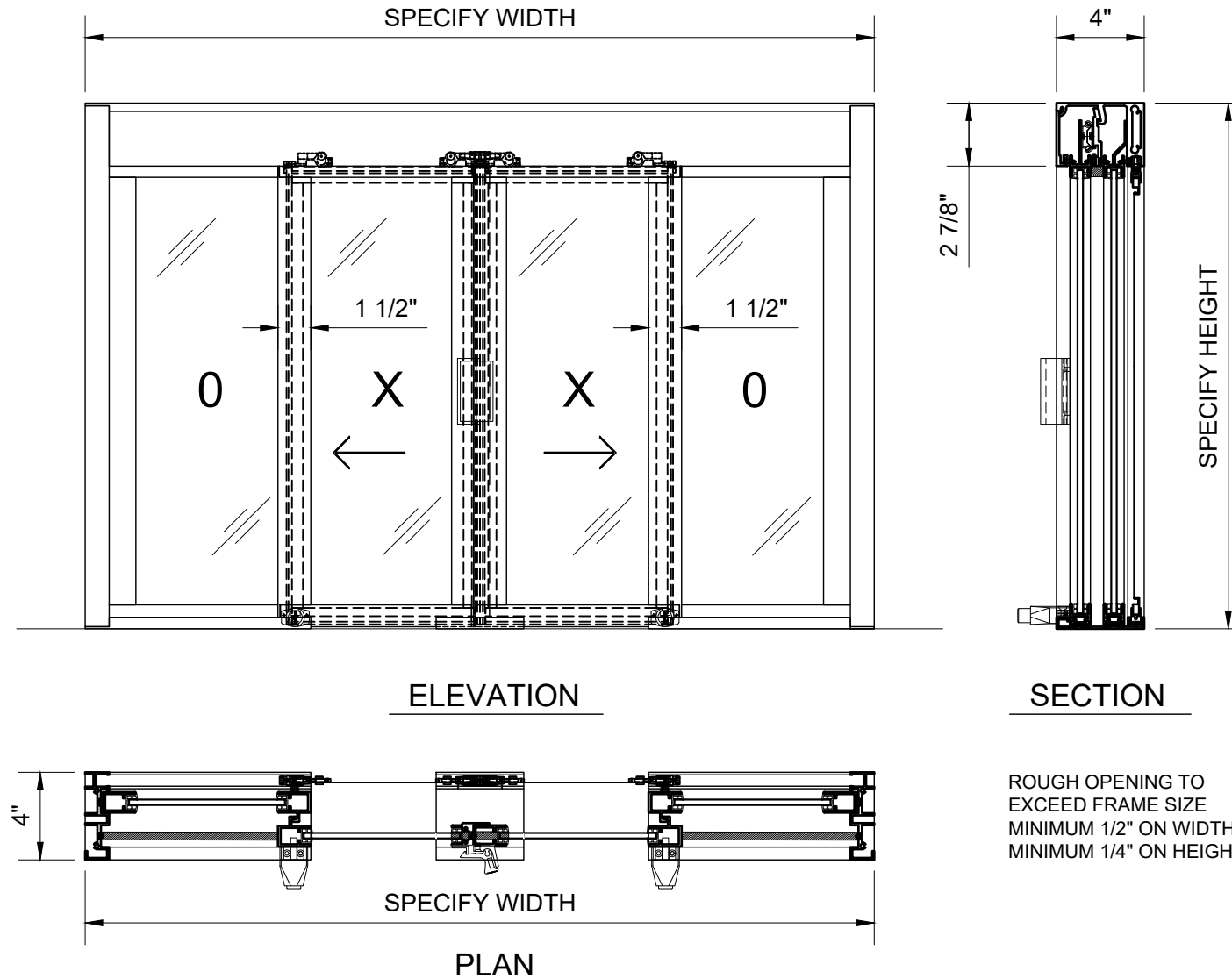

ROUGH OPENING TO EXCEED FRAME SIZE
 MINIMUM 1/2" ON WIDTH
 MINIMUM 1/4" ON HEIGHT

APPLICATIONS :

- DRIVE-THRU / WALK-UP SERVICE
- SECURE RECEPTION AREAS
- INFORMATION / SECURITY KIOSKS

DW SERIES CONFIGURATIONS :

MODEL NUMBERS VARY
 OX XO XX OXO OXXO XOX
 (X=SLIDING O=FIXED)

FULL BOTTOM TRACK
 NO TRACK UNDER SLIDING PANEL(S)

FRAME ASSEMBLY MATERIALS :

- | | |
|------------------------------|-------------------------------|
| 6063-T5 EXTRUDED ALUMINUM | STEEL BALL BEARING CARRIER |
| STAINLESS STEEL FASTENERS | POLY-PILE WEATHERSTRIPPING |
| PLASTIC GUIDES, BLOCKS, CAPS | EXTRUDED VINYL GLAZING GASKET |

OPTIONAL ACCESSORIES :

- KEYED LOCK
- STAINLESS STEEL SHELF OR SILL
- WATER DAM STEP
- PLASTIC LAMINATE SHELF
- TRANSOM LITES / SIDE LITES / RETURNS
- FLY FAN SWITCH (SEPARATE AIR CURTAIN)
- BURGLAR BAR (NOT AVAILABLE ON XX MODELS)

REV.:	11/23/22
DATE:	08/06/19
SCALE:	1-1/2"=1'-0"
DRAWN BY:	RPD

CRL DELUXE SLIDING SERVICE WINDOW KEYED LOCK OPTION AND STANDARD FEATURES

DW3600 (OXXO)
(WITH SCREENS)

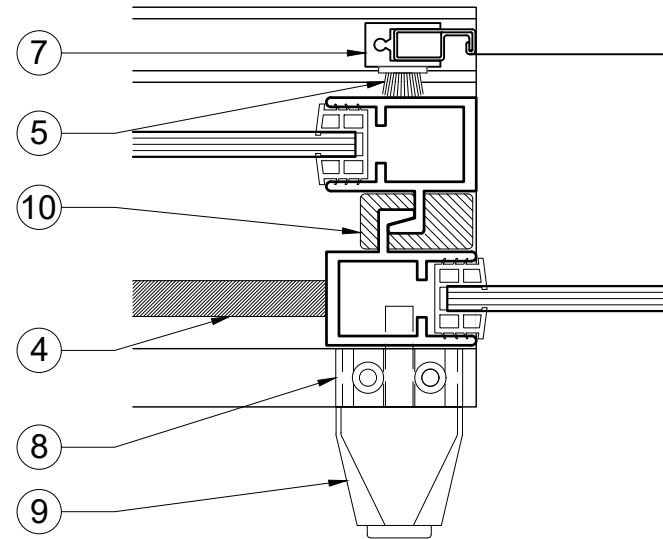

* KEYED LOCK PLAN

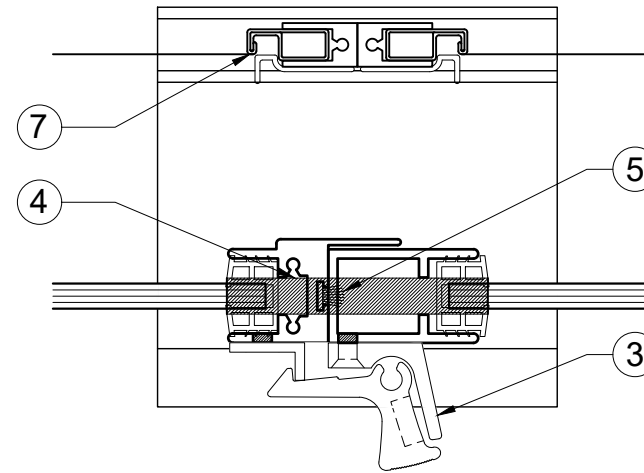

MEETING STILE PLAN

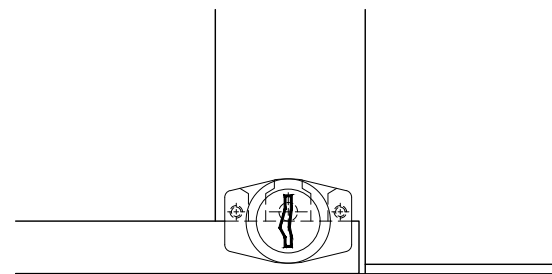

* KEYED LOCK ELEVATION

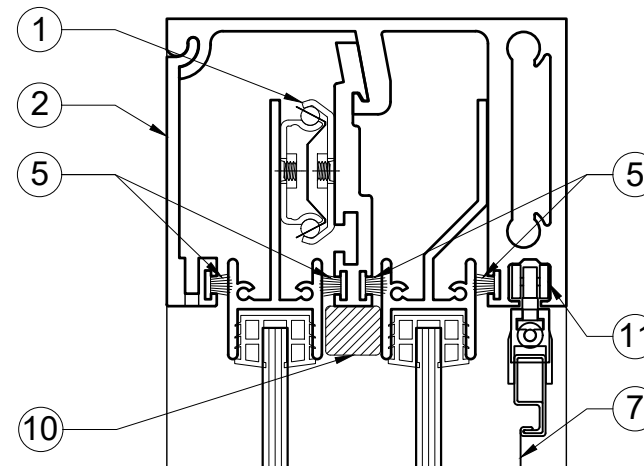

SECTION

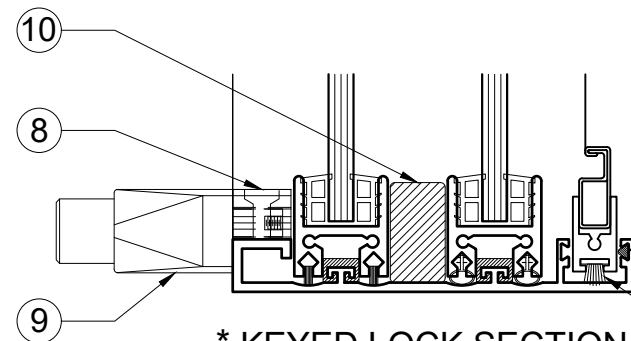

* KEYED LOCK SECTION

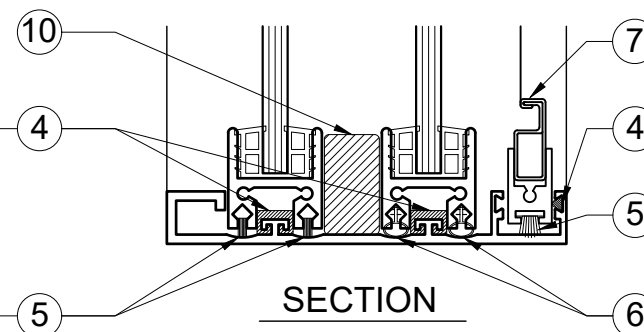

* KEY LOCK MUST BE SPECIFIED

- | | |
|-------------------------|---------------------------------------------|
| 1. HEAVY DUTY CARRIER | 7. SCREEN / FRAME |
| 2. HEADER ACCESS PANEL | 8. ADAPTER BLOCK |
| 3. SELF-LATCHING HANDLE | 9. CRL CAT # 0911BCKA
KEYED PLUNGER LOCK |
| 4. VINYL GUIDES | 10. FILLER BLOCKS |
| 5. WEATHERSTRIPPING | 11. SCREEN ROLLER |
| 6. BULB SEAL | |

* LOCK ADAPTERS VARY PER MODEL

DW4200A DW4200DU DW4200P DW4200K DW4200CA

Two Sliding Panels, No Screen

Standard Anodized Finishes: (A) Satin (Class II Clear), (DU) Duranodic Bronze
 Specified Custom Finishes: (P) Powder Coat, (K) Kynar, (CA) Custom Anodized
 Factory-Glazed Or Installer-Glazed: Glass Thickness Range 1/4" (6mm) To 5/8" (16mm)

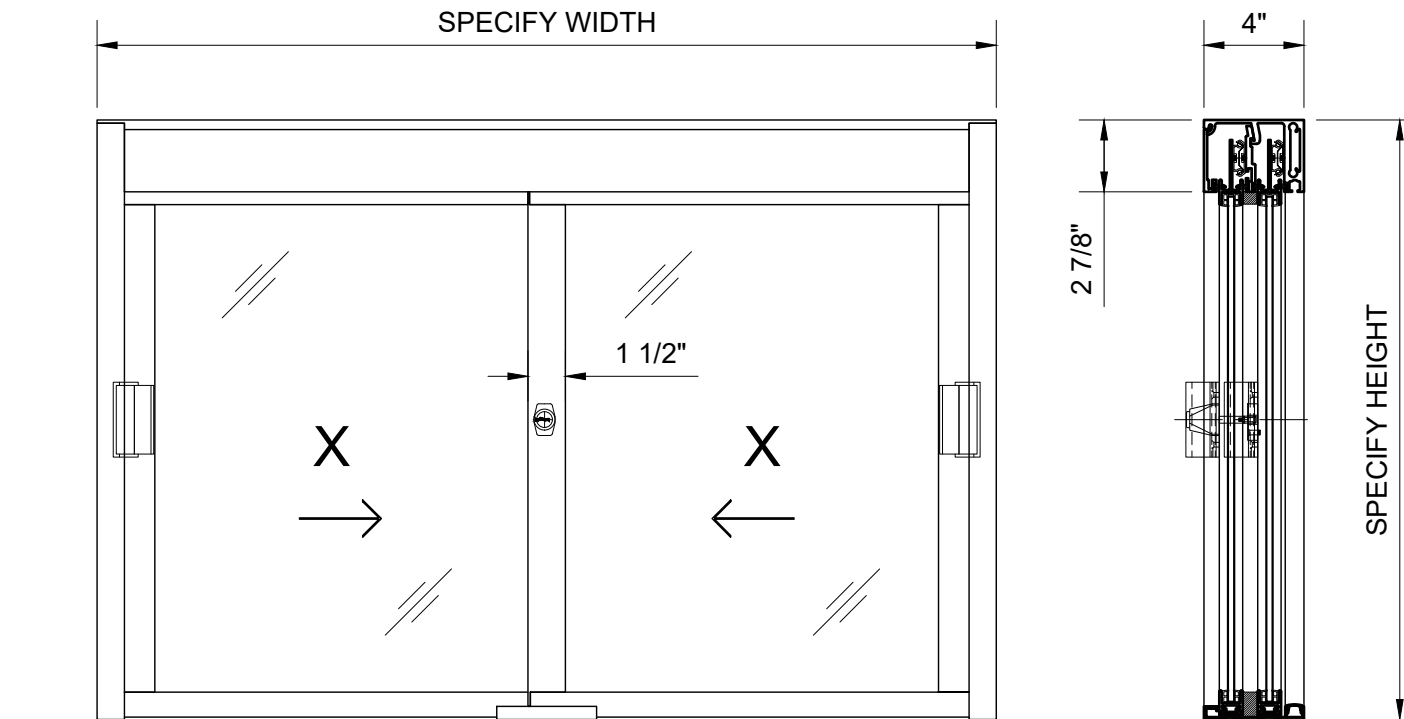

ELEVATION

SECTION

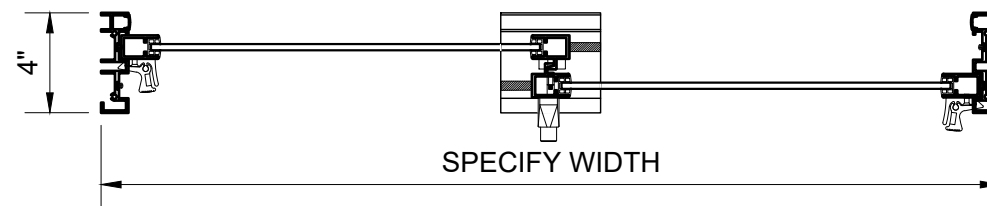

PLAN

ROUGH OPENING TO EXCEED FRAME SIZE
 MINIMUM 1/2" ON WIDTH
 MINIMUM 1/4" ON HEIGHT

APPLICATIONS :

- DRIVE-THRU / WALK-UP SERVICE
- SECURE RECEPTION AREAS
- INFORMATION / SECURITY KIOSKS

DW SERIES CONFIGURATIONS :

MODEL NUMBERS VARY
 OX XO XX OXO OXOXO
 (X=SLIDING O=FIXED)
 FULL BOTTOM TRACK
 NO TRACK UNDER SLIDING PANEL(S)

FRAME ASSEMBLY MATERIALS :

- | | |
|------------------------------|-------------------------------|
| 6063-T5 EXTRUDED ALUMINUM | STEEL BALL BEARING CARRIER |
| STAINLESS STEEL FASTENERS | POLY-PILE WEATHERSTRIPPING |
| PLASTIC GUIDES, BLOCKS, CAPS | EXTRUDED VINYL GLAZING GASKET |

OPTIONAL ACCESSORIES :

- KEYED LOCK
- STAINLESS STEEL SHELF OR SILL
- WATER DAM STEP
- PLASTIC LAMINATE SHELF
- TRANSOM LITES / SIDE LITES / RETURNS
- FLY FAN SWITCH (SEPARATE AIR CURTAIN)
- BURGLAR BAR (NOT AVAILABLE ON XX MODELS)

REV.:	11/23/22
DATE:	08/06/19
SCALE:	1-1/2"=1'-0"
DRAWN BY:	RPD

CRL DELUXE SLIDING SERVICE WINDOW

* KEYED LOCK OPTION AND STANDARD FEATURES

DW4200 (XX)
(NO SCREEN)

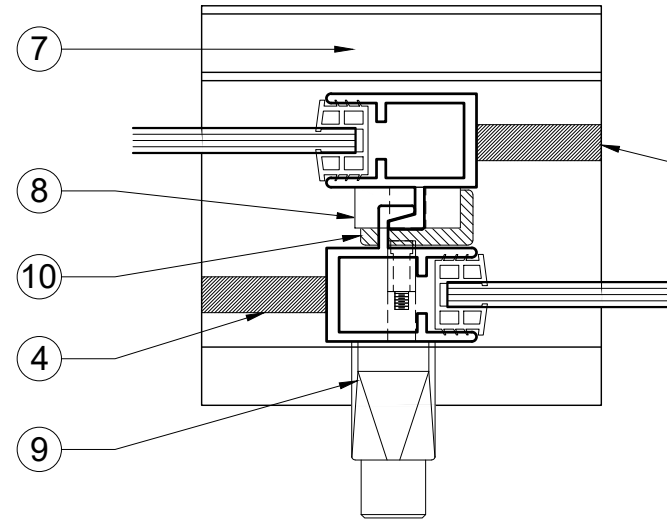

* KEYED LOCK PLAN

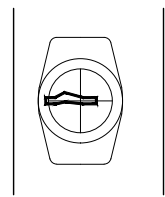

* KEYED LOCK ELEVATION

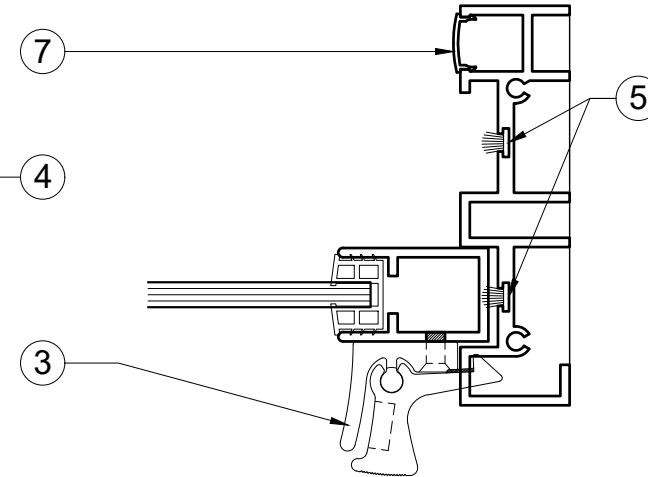

PLAN @ HANDLE

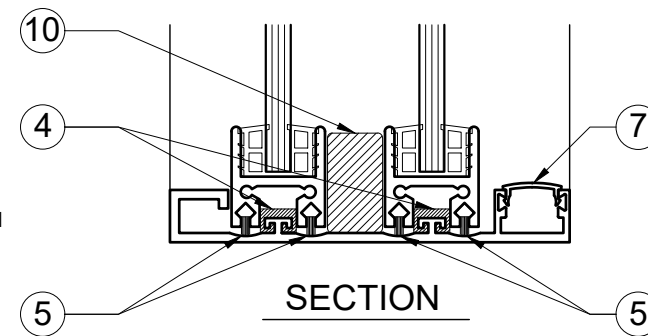
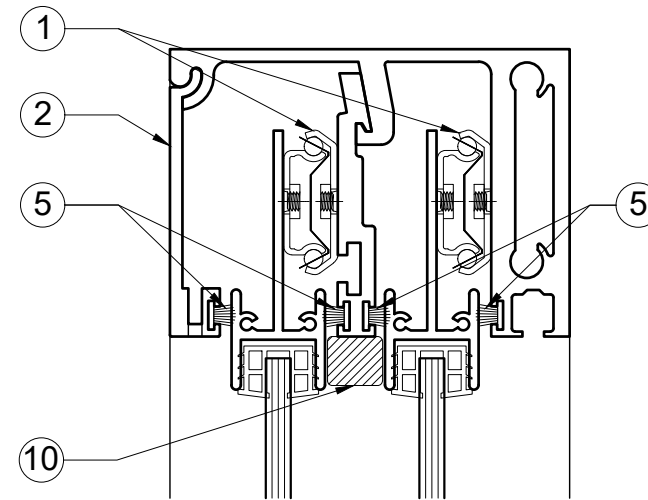

SECTION

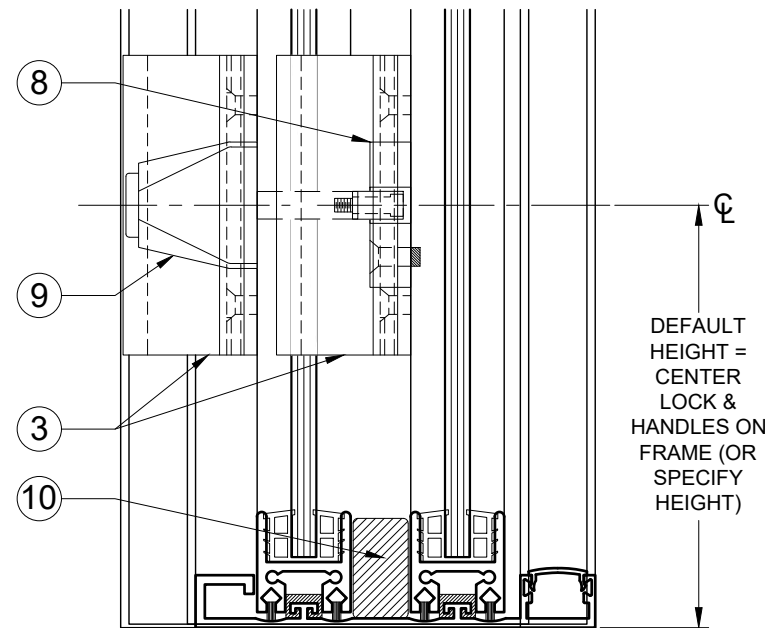

* KEYED LOCK SECTION

* KEY LOCK MUST BE SPECIFIED

☺
DEFAULT
HEIGHT =
CENTER
LOCK &
HANDLES ON
FRAME (OR
SPECIFY
HEIGHT)

- | | |
|-------------------------|---------------------------------------------|
| 1. HEAVY DUTY CARRIER | 7. SCREEN RACE CAP |
| 2. HEADER ACCESS PANEL | 8. STRIKE BLOCK |
| 3. SELF-LATCHING HANDLE | 9. CRL CAT # 0911BCKA
KEYED PLUNGER LOCK |
| 4. VINYL GUIDES | 10. FILLER BLOCKS |
| 5. WEATHERSTRIPPING | |

* LOCK ADAPTERS VARY PER MODEL



C.R.LAURENCE CO. TRANSACTION HARDWARE
2503 E. Vernon Avenue, Los Angeles, C.A 90058-1897
PHONE: (800)-421-6144 Ex.17760 FAX: 800-587-7400
transaction@crlaurence.com www.crlaurence.com

CRL DELUXE SLIDING SERVICE WINDOW

MANUAL OPEN / MANUAL CLOSE

PAGE:
7.2

REV.:	11/23/22
DATE:	08/06/19
SCALE:	6"=1'-0"
DRAWN BY:	RPD

DW4400A DW4400DU DW4400P DW4400K DW4400CA

Two Sliding Panels, With Screen

Standard Anodized Finishes: (A) Satin (Class II Clear), (DU) Duranodic Bronze
 Specified Custom Finishes: (P) Powder Coat, (K) Kynar, (CA) Custom Anodized
 Factory-Glazed Or Installer-Glazed: Glass Thickness Range 1/4" (6mm) To 5/8" (16mm)

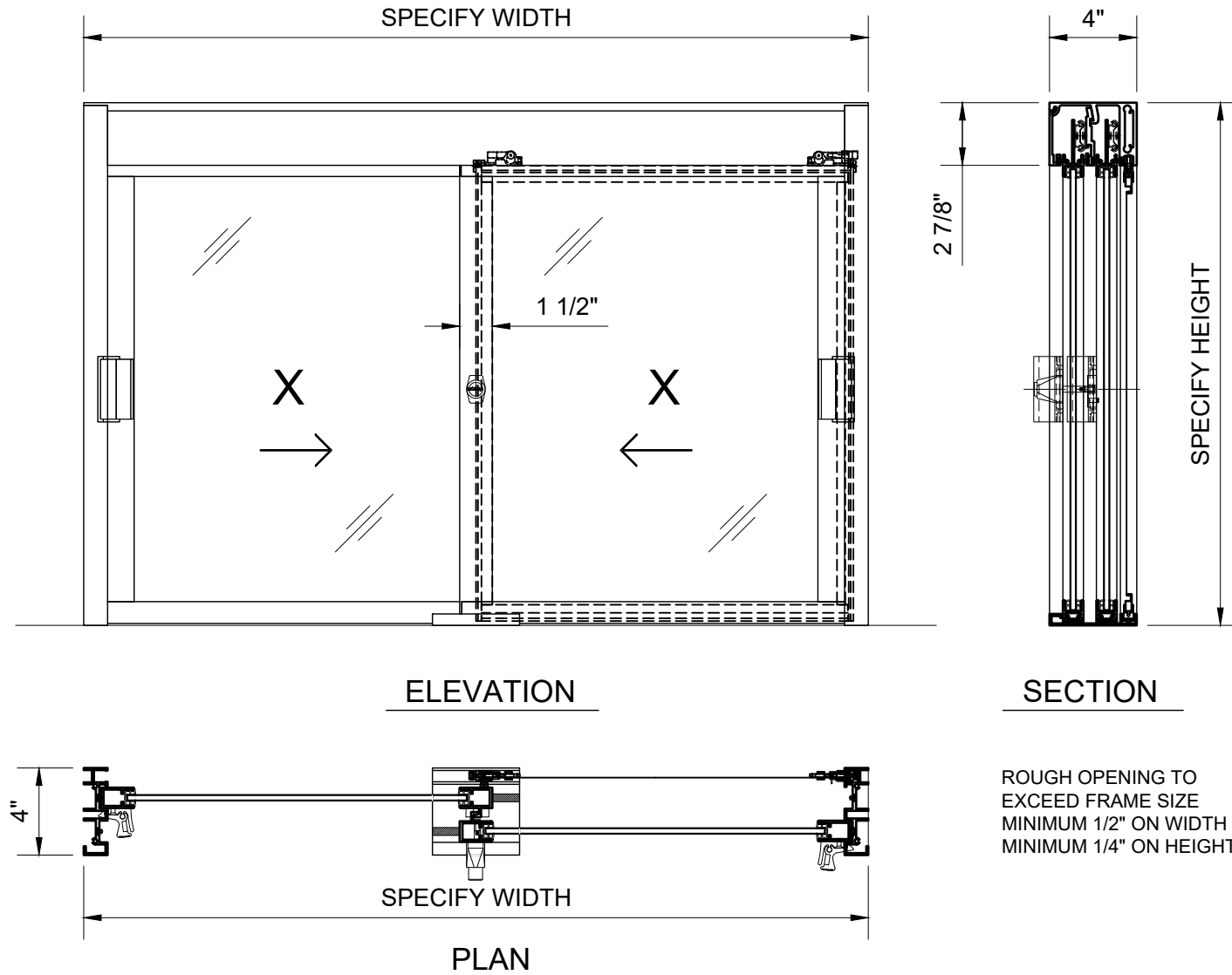

ROUGH OPENING TO EXCEED FRAME SIZE
 MINIMUM 1/2" ON WIDTH
 MINIMUM 1/4" ON HEIGHT

APPLICATIONS :

- DRIVE-THRU / WALK-UP SERVICE
- SECURE RECEPTION AREAS
- INFORMATION / SECURITY KIOSKS

DW SERIES CONFIGURATIONS :

MODEL NUMBERS VARY
 OX XO XX OXO OXXO XOX
 (X=SLIDING O=FIXED)

FULL BOTTOM TRACK
 NO TRACK UNDER SLIDING PANEL(S)

FRAME ASSEMBLY MATERIALS :

- | | |
|------------------------------|-------------------------------|
| 6063-T5 EXTRUDED ALUMINUM | STEEL BALL BEARING CARRIER |
| STAINLESS STEEL FASTENERS | POLY-PILE WEATHERSTRIPPING |
| PLASTIC GUIDES, BLOCKS, CAPS | EXTRUDED VINYL GLAZING GASKET |

OPTIONAL ACCESSORIES :

- KEYED LOCK
- STAINLESS STEEL SHELF OR SILL
- WATER DAM STEP
- PLASTIC LAMINATE SHELF
- TRANSOM LITES / SIDE LITES / RETURNS
- FLY FAN SWITCH (SEPARATE AIR CURTAIN)
- BURGLAR BAR (NOT AVAILABLE ON XX MODELS)



C.R.LAURENCE CO. TRANSACTION HARDWARE
 2503 E. Vernon Avenue, Los Angeles, C.A 90058-1897
 PHONE: (800)-421-6144 Ex.17760 FAX: 800-587-7000
 transaction@crlaurence.com www.crlaurence.com

CRL DELUXE SLIDING SERVICE WINDOW

MANUAL OPEN / MANUAL CLOSE

PAGE: 8.1

REV.:	11/23/22
DATE:	08/06/19
SCALE:	1-1/2"=1'-0"
DRAWN BY:	RPD

CRL DELUXE SLIDING SERVICE WINDOW KEYED LOCK OPTION AND STANDARD FEATURES

DW4400 (XX)
(WITH SCREEN)

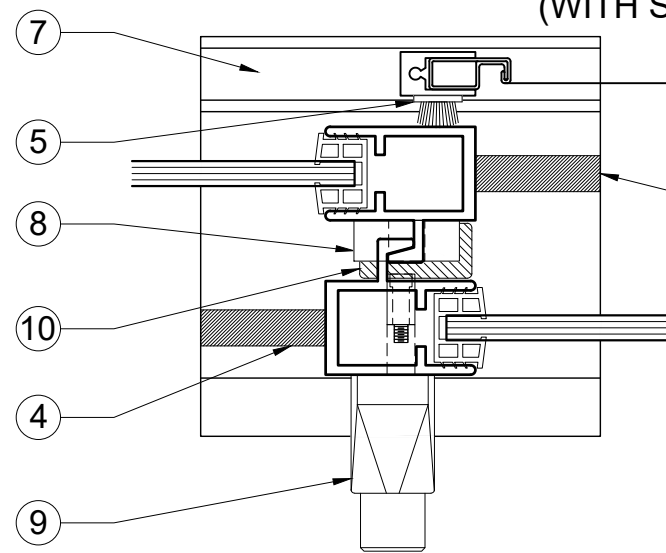

* KEYED LOCK PLAN

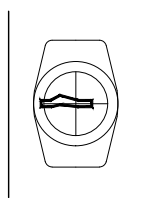

* KEYED LOCK ELEVATION

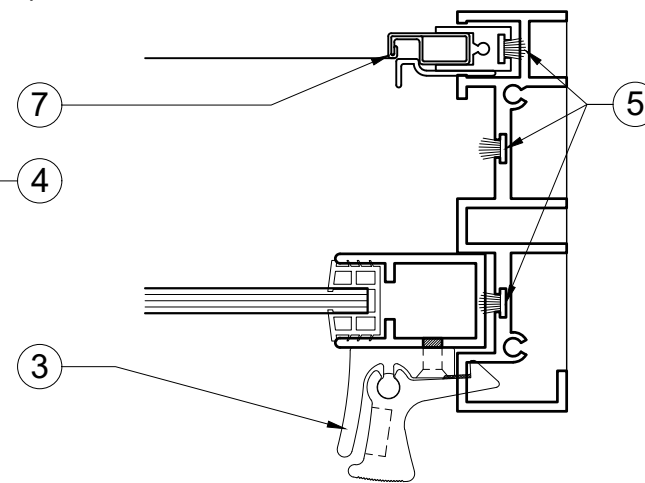

PLAN @ HANDLE

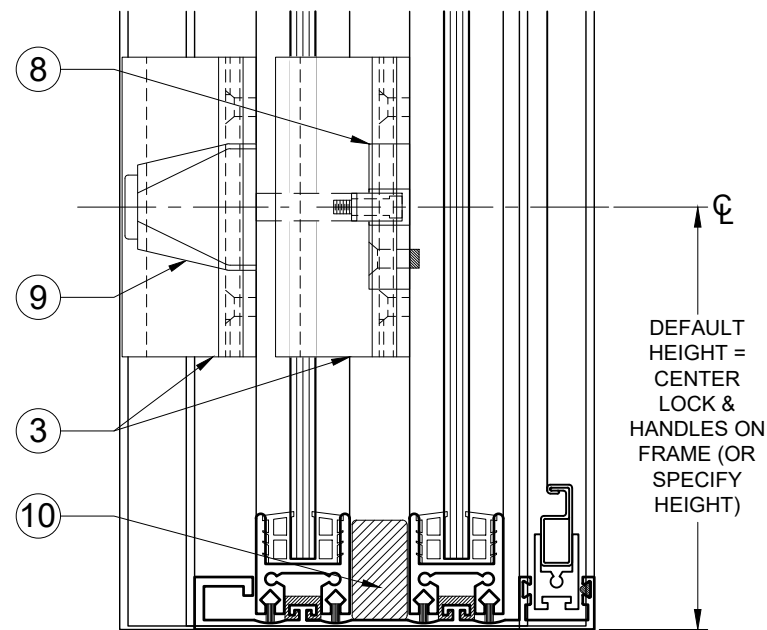

* KEYED LOCK SECTION

* KEY LOCK MUST BE SPECIFIED

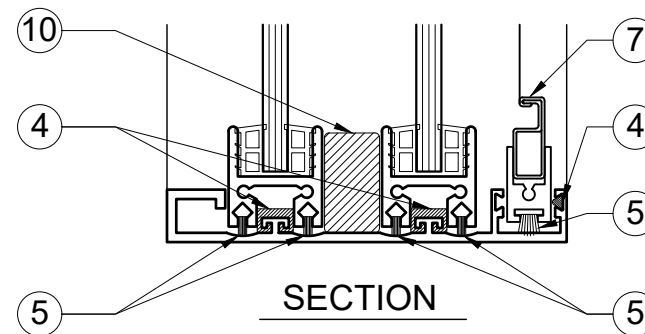
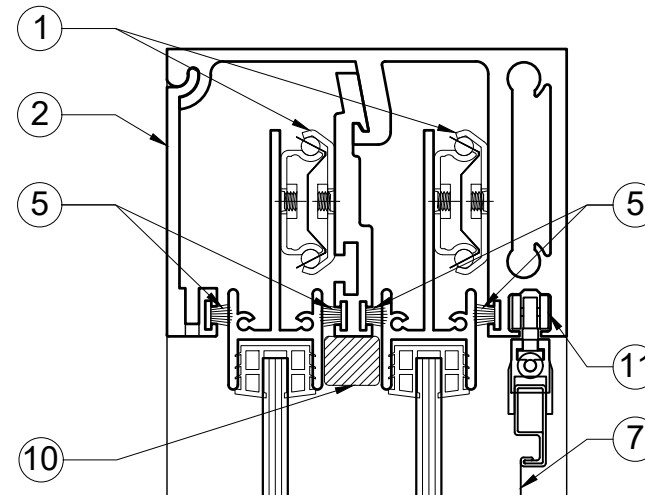

SECTION

- | | |
|-------------------------|---------------------------------------------|
| 1. HEAVY DUTY CARRIER | 7. SCREEN / FRAME |
| 2. HEADER ACCESS PANEL | 8. STRIKE BLOCK |
| 3. SELF-LATCHING HANDLE | 9. CRL CAT # 0911BCKA
KEYED PLUNGER LOCK |
| 4. VINYL GUIDES | 10. FILLER BLOCKS |
| 5. WEATHERSTRIPPING | 11. SCREEN ROLLER |

* LOCK ADAPTERS VARY PER MODEL



C.R.LAURENCE CO. TRANSACTION HARDWARE
2503 E. Vernon Avenue, Los Angeles, C.A 90058-1897
PHONE: (800)-421-6144 Ex.17760 FAX: 800-587-7400
transaction@crlaurence.com www.crlaurence.com

CRL DELUXE SLIDING SERVICE WINDOW

MANUAL OPEN / MANUAL CLOSE

PAGE:

8.2

REV.:	11/23/22
DATE:	08/06/19
SCALE:	6"=1'-0"
DRAWN BY:	RPD

DW5000A DW5000DU DW5000P DW5000K DW5000CA

One Fixed / Two Sliding Panels, No Screens

Standard Anodized Finishes: (A) Satin (Class II Clear), (DU) DuraNodic Bronze
 Specified Custom Finishes: (P) Powder Coat, (K) Kynar, (CA) Custom Anodized
 Factory-Glazed Or Installer-Glazed: Glass Thickness Range 1/4" (6mm) To 5/8" (16mm)

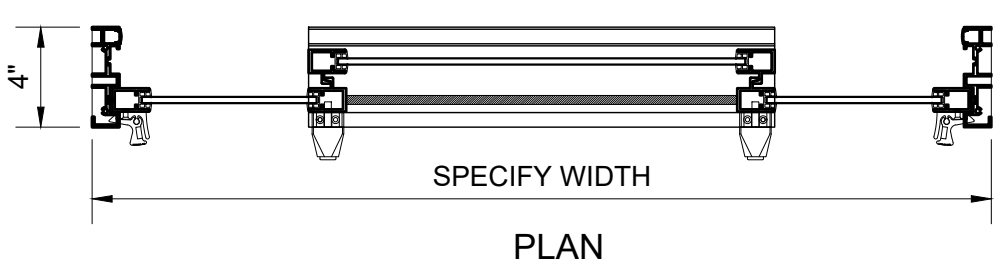
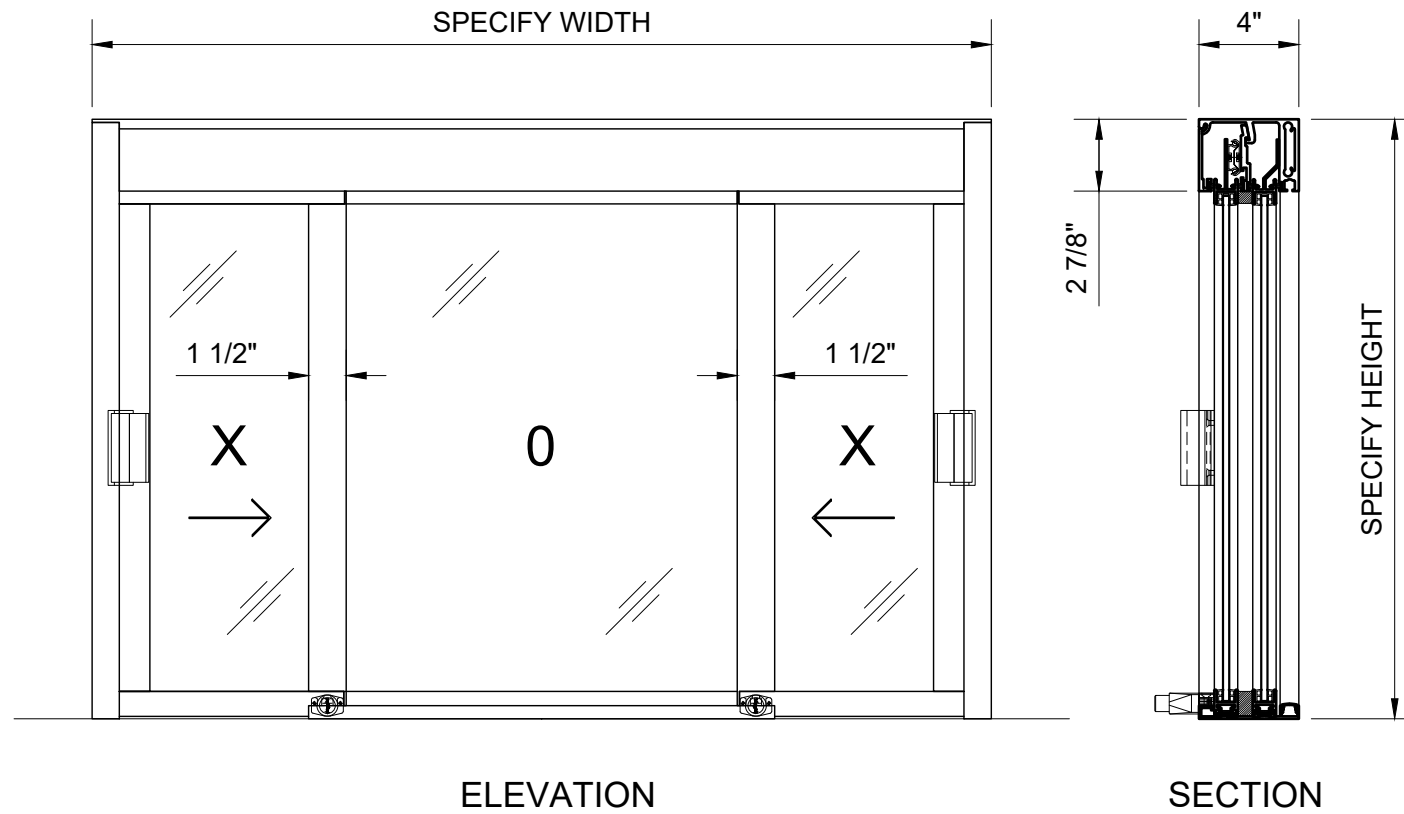

ROUGH OPENING TO EXCEED FRAME SIZE
 MINIMUM 1/2" ON WIDTH
 MINIMUM 1/4" ON HEIGHT

APPLICATIONS :

- DRIVE-THRU / WALK-UP SERVICE
- SECURE RECEPTION AREAS
- INFORMATION / SECURITY KIOSKS

FRAME ASSEMBLY MATERIALS :

- | | |
|------------------------------|-------------------------------|
| 6063-T5 EXTRUDED ALUMINUM | STEEL BALL BEARING CARRIER |
| STAINLESS STEEL FASTENERS | POLY-PILE WEATHERSTRIPPING |
| PLASTIC GUIDES, BLOCKS, CAPS | EXTRUDED VINYL GLAZING GASKET |

DW SERIES CONFIGURATIONS :

MODEL NUMBERS VARY
 OX XO XX OXO OXXO XO
 (X=SLIDING O=FIXED)
 FULL BOTTOM TRACK
 NO TRACK UNDER SLIDING PANEL(S)

OPTIONAL ACCESSORIES :

- KEYED LOCK
- STAINLESS STEEL SHELF OR SILL
- WATER DAM STEP
- PLASTIC LAMINATE SHELF
- TRANSOM LITES / SIDE LITES / RETURNS
- FLY FAN SWITCH (SEPARATE AIR CURTAIN)
- BURGLAR BAR (NOT AVAILABLE ON XX MODELS)

CRL DELUXE SLIDING SERVICE WINDOW KEYED LOCK OPTION AND STANDARD FEATURES

DW5000 (XOX)
(NO SCREENS)

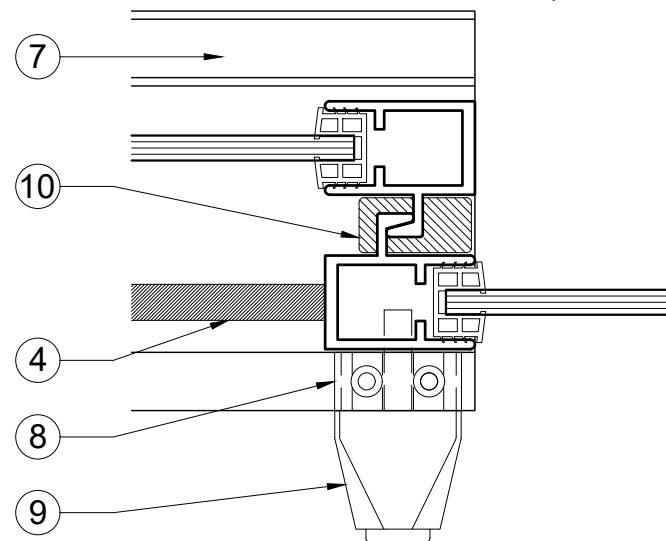

* KEYED LOCK PLAN

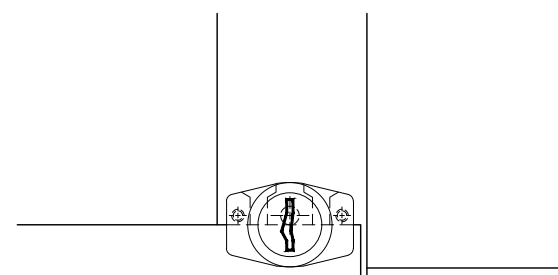

* KEYED LOCK ELEVATION

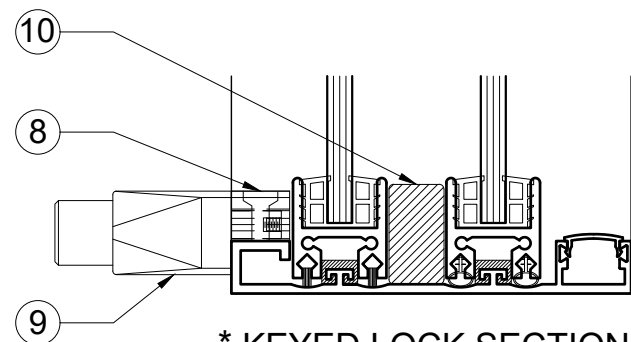

* KEYED LOCK SECTION

* KEY LOCK MUST BE SPECIFIED

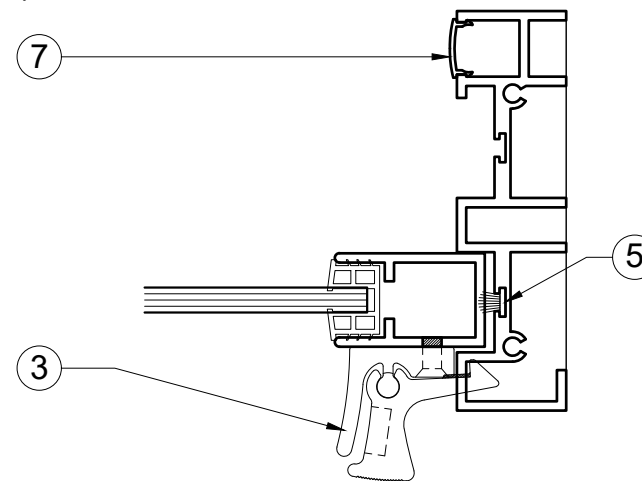

PLAN @ HANDLE

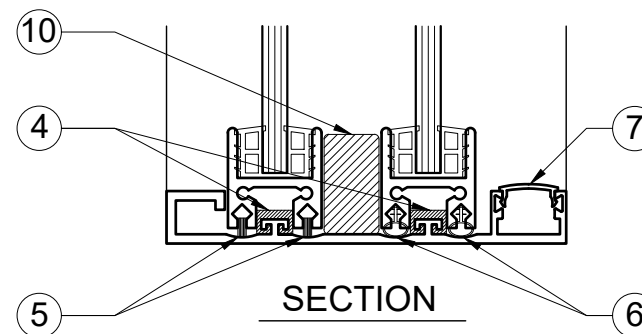
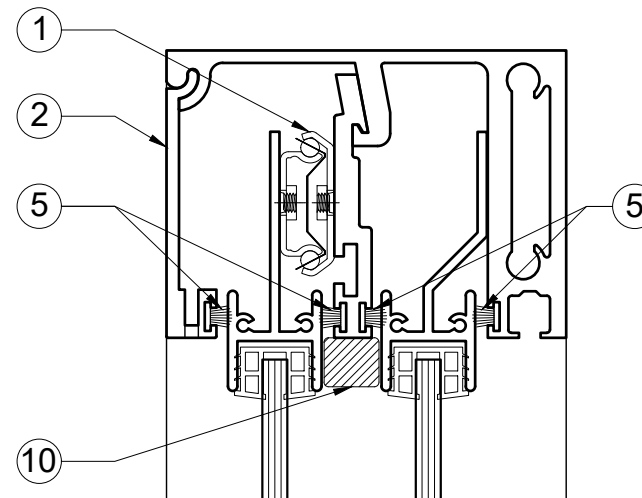

- 1. HEAVY DUTY CARRIER
- 2. HEADER ACCESS PANEL
- 3. SELF-LATCHING HANDLE
- 4. VINYL GUIDES
- 5. WEATHERSTRIPPING
- 6. BULB SEAL
- 7. SCREEN RACE CAP
- 8. ADAPTER BLOCK
- 9. CRL CAT # 0911BCKA
KEYED PLUNGER LOCK
- 10. FILLER BLOCKS

* LOCK ADAPTERS VARY PER MODEL



C.R.LAURENCE CO. TRANSACTION HARDWARE
2503 E. Vernon Avenue, Los Angeles, C.A 90058-1897
PHONE: (800)-421-6144 Ex.17760 FAX: 800-587-7100
transaction@crlaurence.com www.crlaurence.com

CRL DELUXE SLIDING SERVICE WINDOW

MANUAL OPEN / MANUAL CLOSE

PAGE:
9.2

REV.:	11/23/22
DATE:	08/06/19
SCALE:	6"=1'-0"
DRAWN BY:	RPD

DW5200A DW5200DU DW5200P DW5200K DW5200CA

One Fixed / Two Sliding Panels, With Screens

Standard Anodized Finishes: (A) Satin (Class II Clear), (DU) Duranodic Bronze
 Specified Custom Finishes: (P) Powder Coat, (K) Kynar, (CA) Custom Anodized
 Factory-Glazed Or Installer-Glazed: Glass Thickness Range 1/4" (6mm) To 5/8" (16mm)

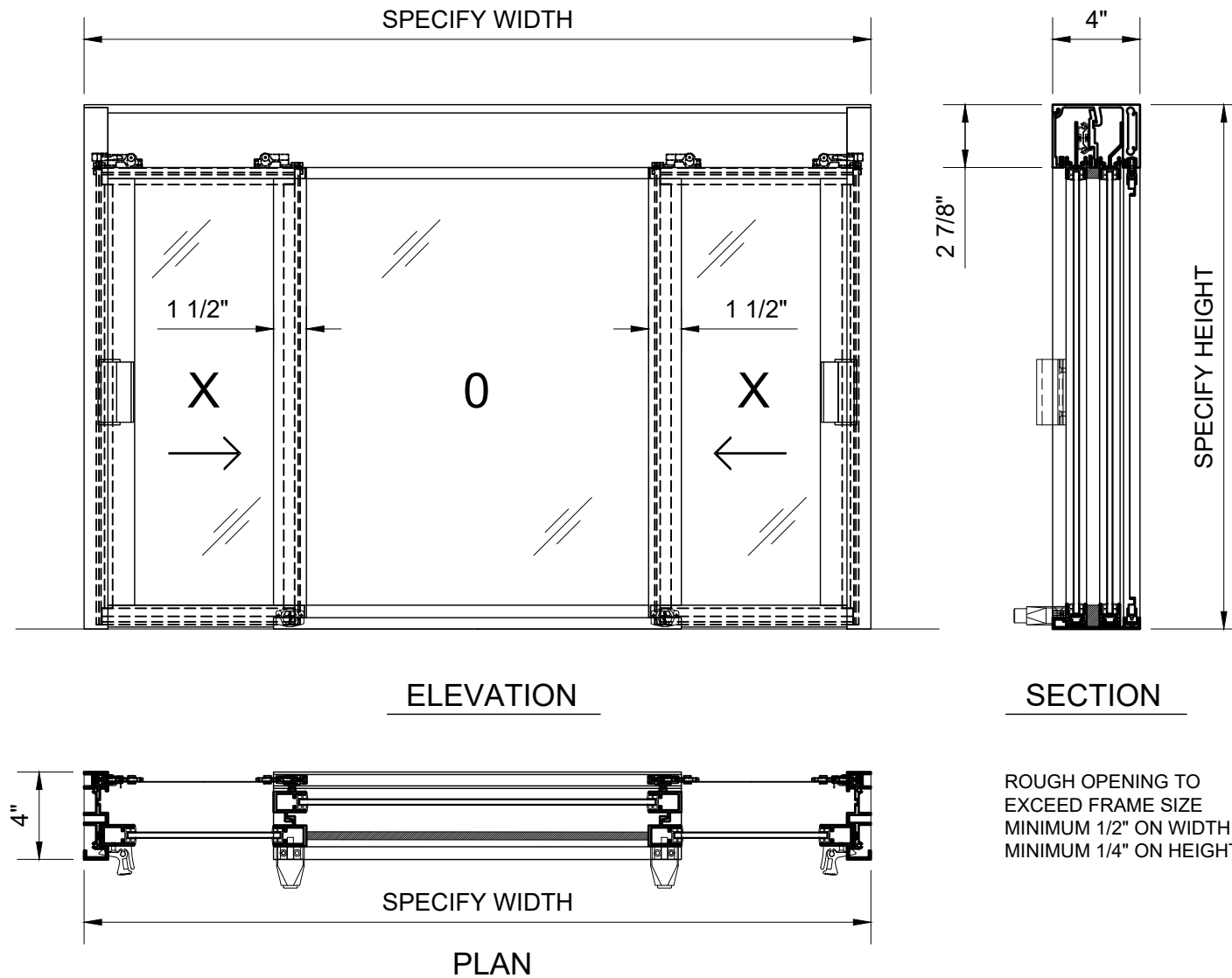

ROUGH OPENING TO EXCEED FRAME SIZE
 MINIMUM 1/2" ON WIDTH
 MINIMUM 1/4" ON HEIGHT

APPLICATIONS :

- DRIVE-THRU / WALK-UP SERVICE
- SECURE RECEPTION AREAS
- INFORMATION / SECURITY KIOSKS

DW SERIES CONFIGURATIONS :

MODEL NUMBERS VARY
 OX XO XX OXO OXOX
 (X=SLIDING O=FIXED)
 FULL BOTTOM TRACK
 NO TRACK UNDER SLIDING PANEL(S)

FRAME ASSEMBLY MATERIALS :

6063-T5 EXTRUDED ALUMINUM STEEL BALL BEARING CARRIER
 STAINLESS STEEL FASTENERS POLY-PILE WEATHERSTRIPPING
 PLASTIC GUIDES, BLOCKS, CAPS EXTRUDED VINYL GLAZING GASKET

OPTIONAL ACCESSORIES :

- KEYED LOCK
- STAINLESS STEEL SHELF OR SILL
- WATER DAM STEP
- PLASTIC LAMINATE SHELF
- TRANSOM LITES / SIDE LITES / RETURNS
- FLY FAN SWITCH (SEPARATE AIR CURTAIN)
- BURGLAR BAR (NOT AVAILABLE ON XX MODELS)



C.R.LAURENCE CO. TRANSACTION HARDWARE
 2503 E. Vernon Avenue, Los Angeles, C.A 90058-1897
 PHONE: (800)-421-6144 Ex.17760 FAX: 800-587-7101
 transaction@crlaurence.com www.crlaurence.com

CRL DELUXE SLIDING SERVICE WINDOW

MANUAL OPEN / MANUAL CLOSE

PAGE: 10.1

REV.:	11/23/22
DATE:	08/06/19
SCALE:	1-1/2"=1'-0"
DRAWN BY:	RPD

CRL DELUXE SLIDING SERVICE WINDOW KEYED LOCK OPTION AND STANDARD FEATURES

DW5200 (XOX)
(WITH SCREENS)

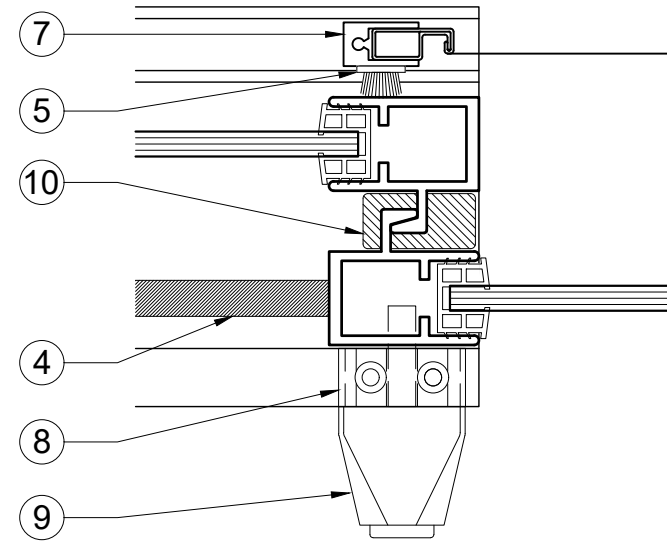

* KEYED LOCK PLAN

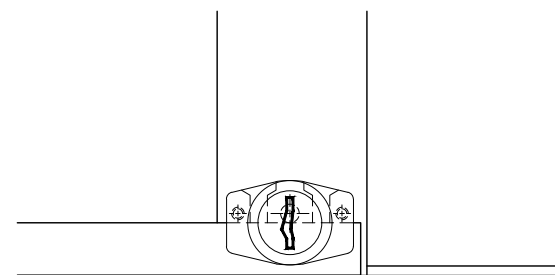

* KEYED LOCK ELEVATION

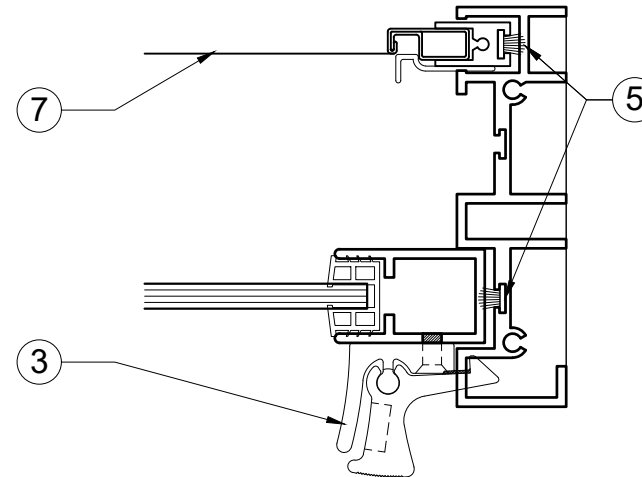

PLAN @ HANDLE

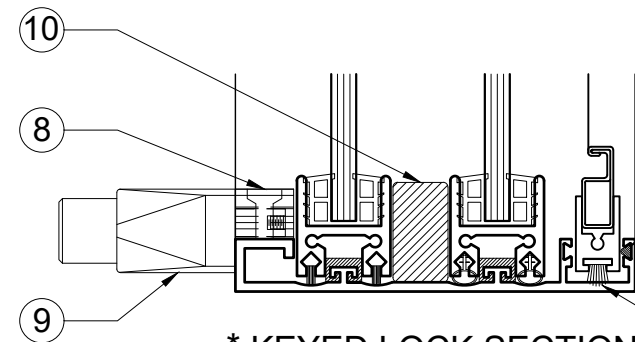
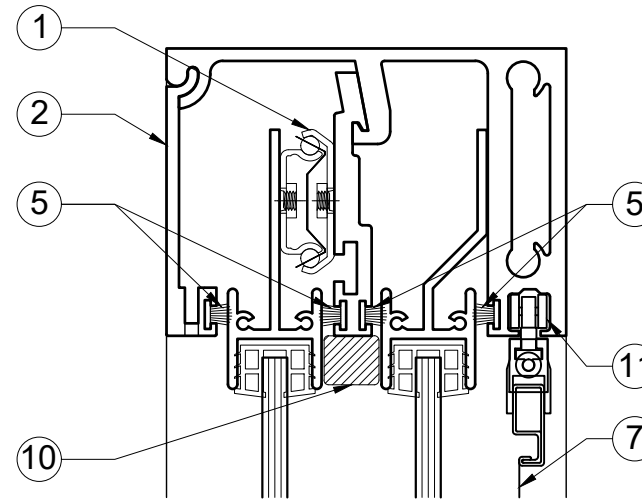

* KEYED LOCK SECTION

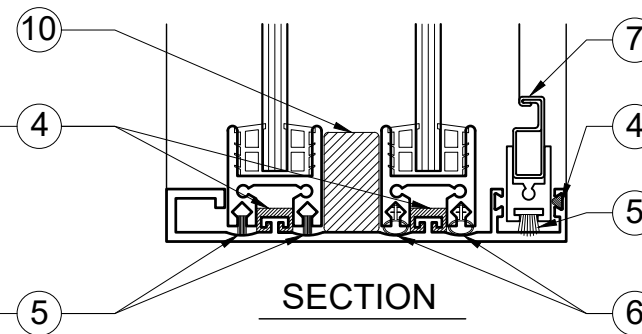

SECTION

* KEY LOCK MUST BE SPECIFIED

- | | |
|-------------------------|---------------------------------------------|
| 1. HEAVY DUTY CARRIER | 7. SCREEN / FRAME |
| 2. HEADER ACCESS PANEL | 8. ADAPTER BLOCK |
| 3. SELF-LATCHING HANDLE | 9. CRL CAT # 0911BCKA
KEYED PLUNGER LOCK |
| 4. VINYL GUIDES | 10. FILLER BLOCKS |
| 5. WEATHERSTRIPPING | 11. SCREEN ROLLER |
| 6. BULB SEAL | |

* LOCK ADAPTERS VARY PER MODEL



C.R.LAURENCE CO. TRANSACTION HARDWARE
2503 E. Vernon Avenue, Los Angeles, C.A 90058-1897
PHONE: (800)-421-6144 Ex.17760 FAX: 800-587-7100
transaction@crlaurence.com www.crlaurence.com

CRL DELUXE SLIDING SERVICE WINDOW

MANUAL OPEN / MANUAL CLOSE

PAGE:
10.2

REV.:	11/23/22
DATE:	08/06/19
SCALE:	6"=1'-0"
DRAWN BY:	RPD

**TRANSOM / SIDELITE OPTIONS
WITH 4" DEEP ALUMINUM NARROW INSET FRAME**

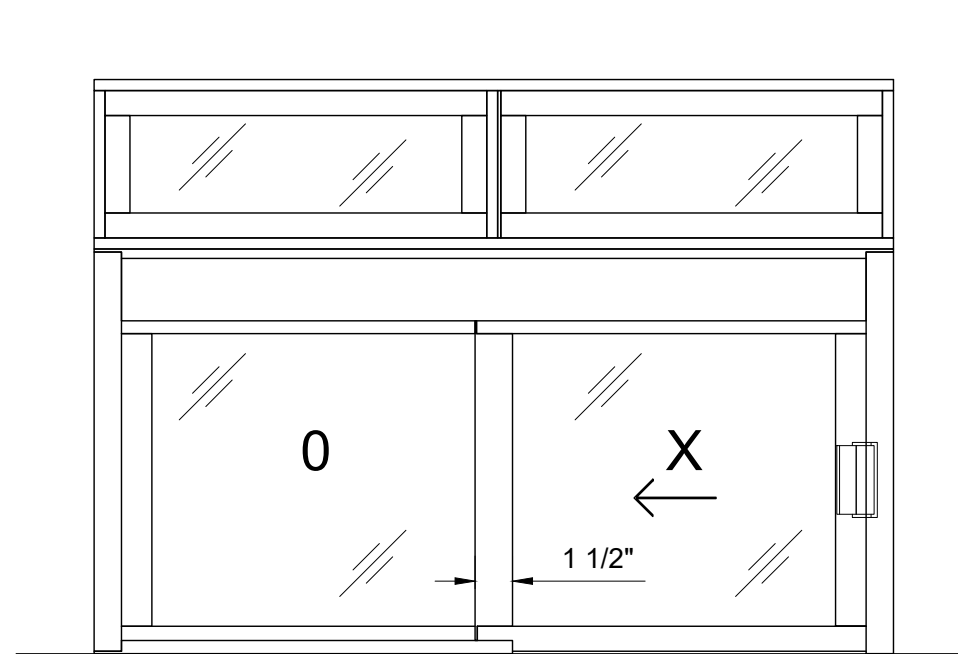

ELEVATION: DW1800 2-LITE TRANSOM

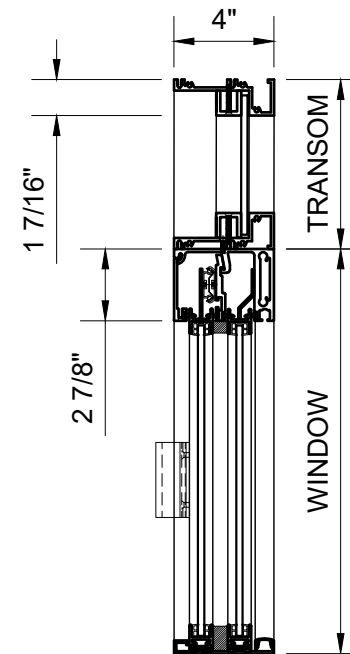

SECTION

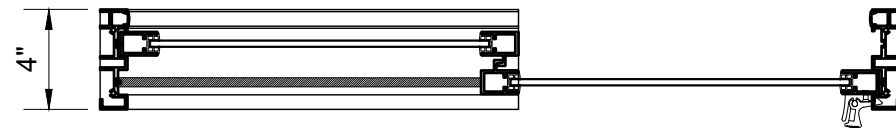

PLAN: WINDOW

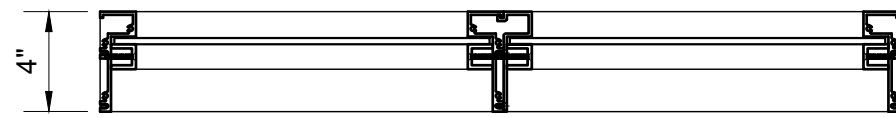

PLAN: TRANSOM

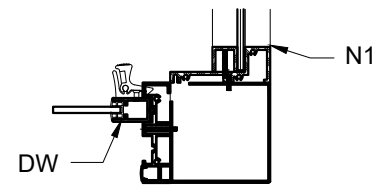

BRAKE METAL INSERT
FOR 90 DEG. RETURNS

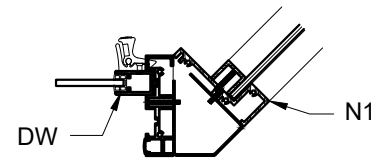

BRAKE METAL INSERT FOR
CUSTOM ANGLE RETURNS

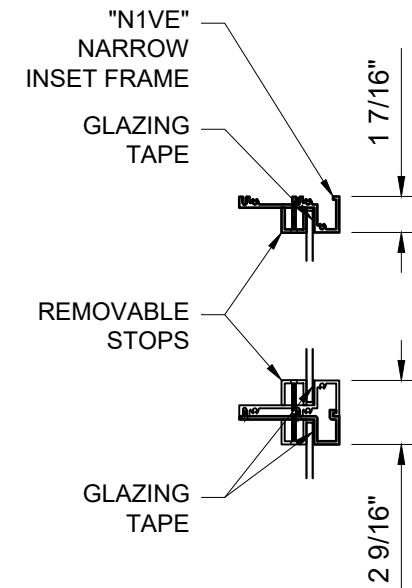

REV.: 11/23/22

DATE: 08/06/19

SCALE: NO SCALE

DRAWN BY: RPD



**TRANSOM / SIDELITE OPTIONS
WITH 4" DEEP ALUMINUM NARROW INSET FRAME**

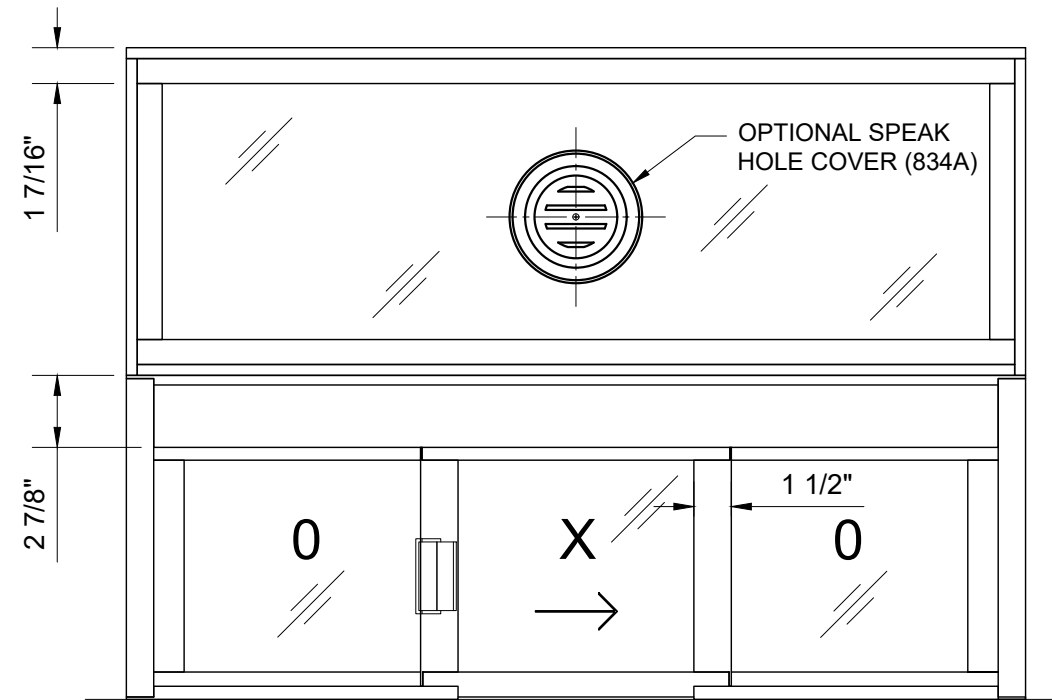

DW2600 SINGLE-LITE TRANSOM

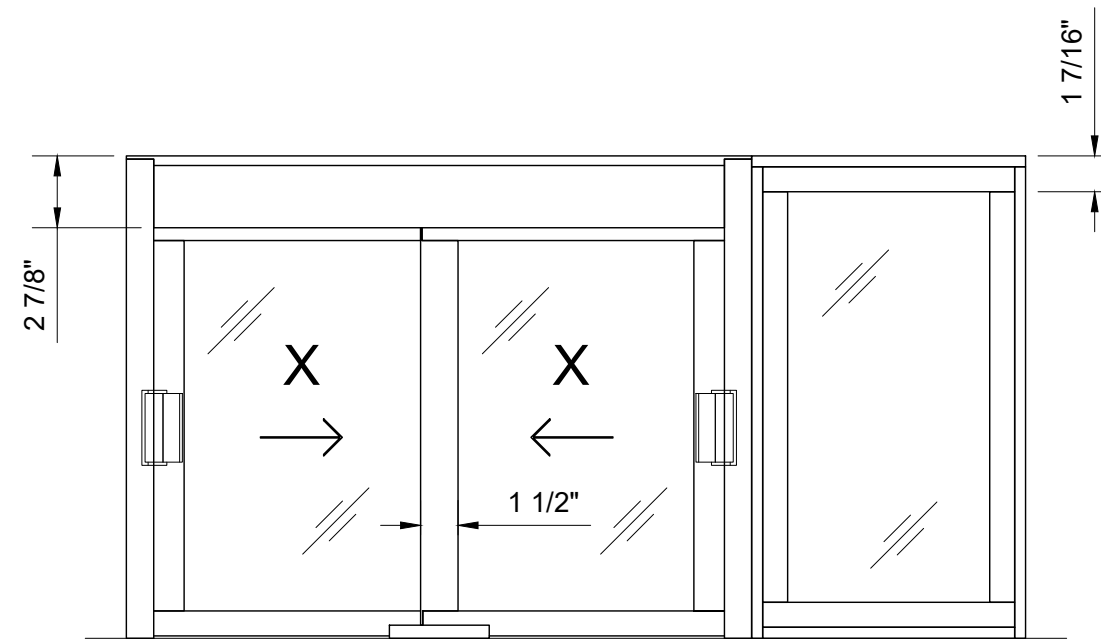

DW4200 180 DEG. SIDE LITE

**TRANSOM / SIDELITE OPTIONS
WITH 4" DEEP ALUMINUM NARROW INSET FRAME**

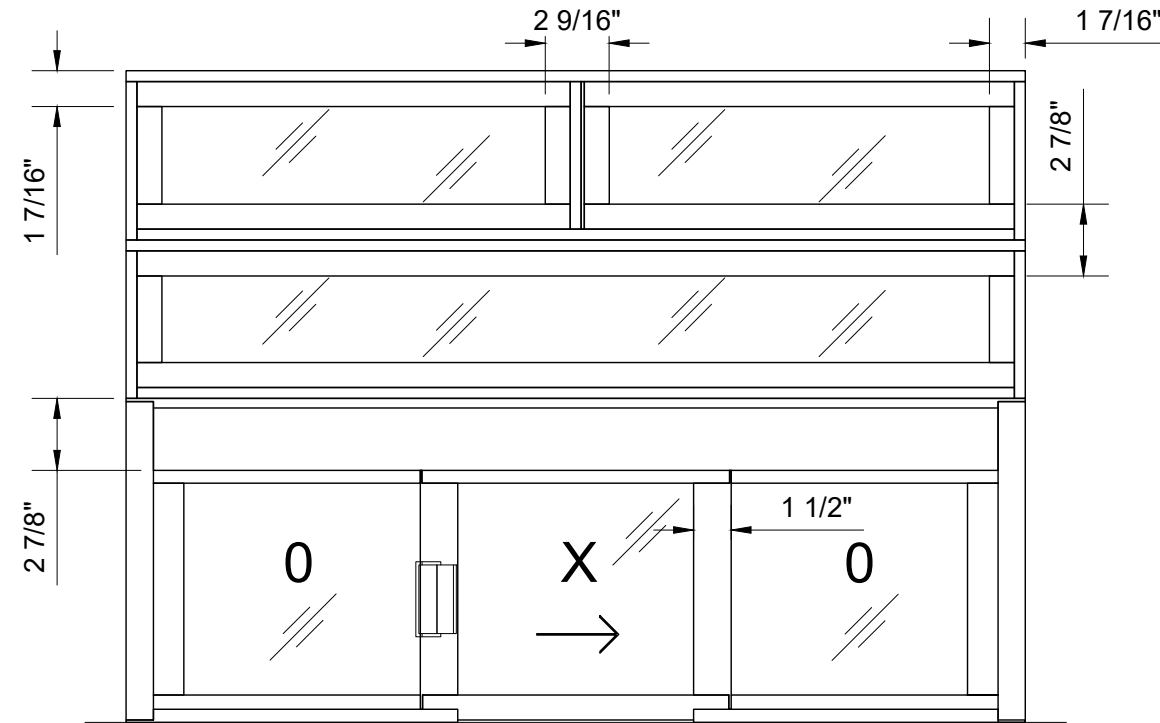

DW2600 CUSTOM TRANSOM

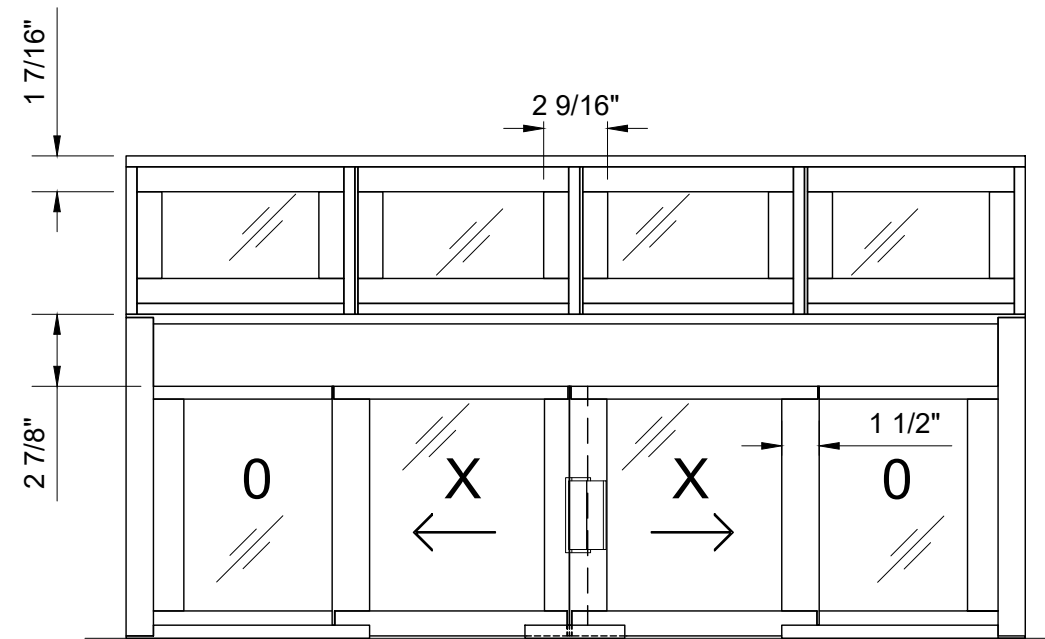

DW3400 MULTI-LITE TRANSOM

SHELF / SILL OPTIONS

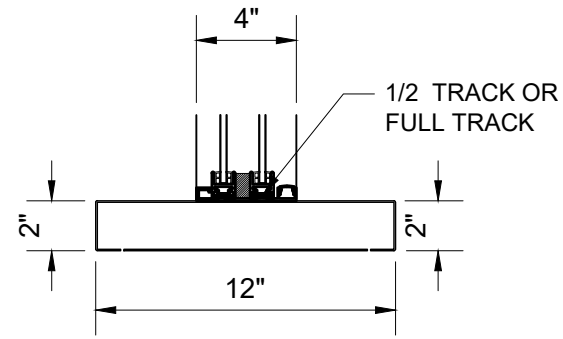

FLAT STAINLESS STEEL SHELF
16 GA. BRUSHED # 4 FINISH

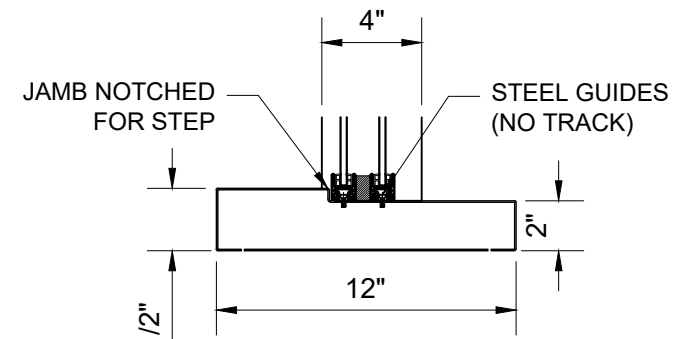

STAINLESS STEEL SHELF WITH
1/2" STEP FOR WATER DAM

SPECIFY SHELF DEPTH (30" MAX) AND
PROJECTION IN / OUT (SILL MATCHES FRAME)

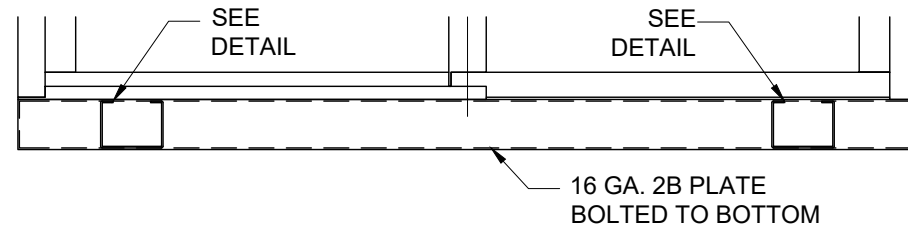

ELEVATION: INTERNAL 16 GA. SHELF SUPPORTS

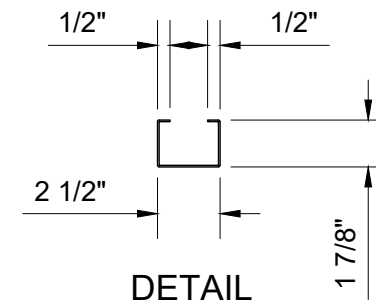

DETAIL

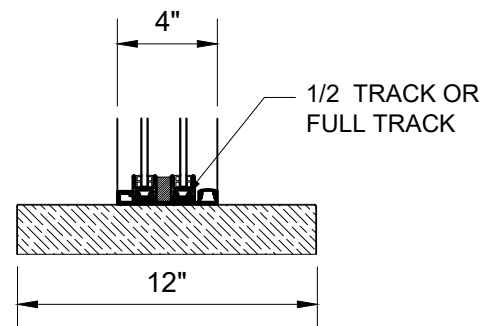

PLASTIC LAMINATE SHELF
STANDARD BLACK OR
SPECIFY WILSONART COLOR #

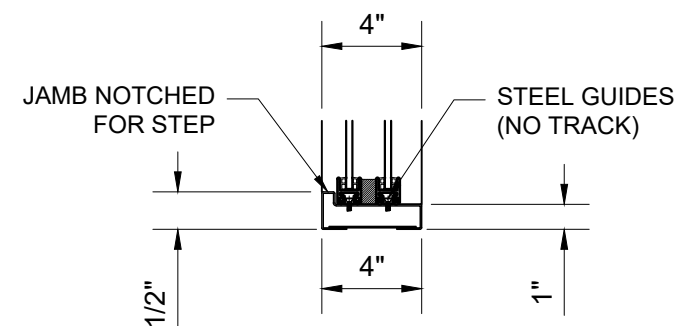

STAINLESS STEEL SILL WITH
1/2" STEP FOR WATER DAM

- CRL DELUXE SLIDING SERVICE WINDOWS CAN INCLUDE A HIGH-QUALITY STAINLESS-STEEL SHELF OR SILL, OR PLYWOOD / PLASTIC LAMINATE SHELF.
- 4" DEEP SILL OPTION SHIPS ATTACHED TO FRAME.
- SHELF OPTIONS CAN SHIP ATTACHED OR IN A SEPARATE CARTON UPON REQUEST.
- RADIUS CORNERS AND INTEGRAL DEAL TRAYS AVAILABLE WITH FLAT STEEL SHELVES ONLY.
- RECESSED, "DROP-IN" DEAL TRAYS AVAILABLE WITH LAMINATE SHELVES.
- CONTACT CRL FOR MORE INFORMATION ON CUSTOM SHELF OPTIONS.