

SERIES CABR65 AND CAB65 CABO SOFT SLIDE SLIDING SHOWER DOOR SYSTEM (180° INSTALLATION)

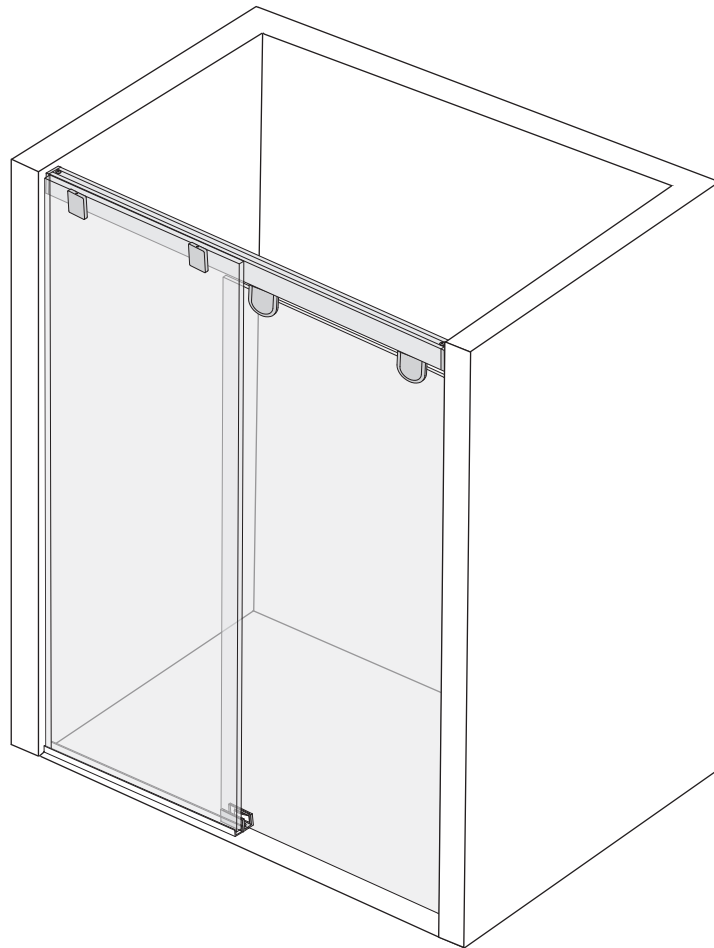

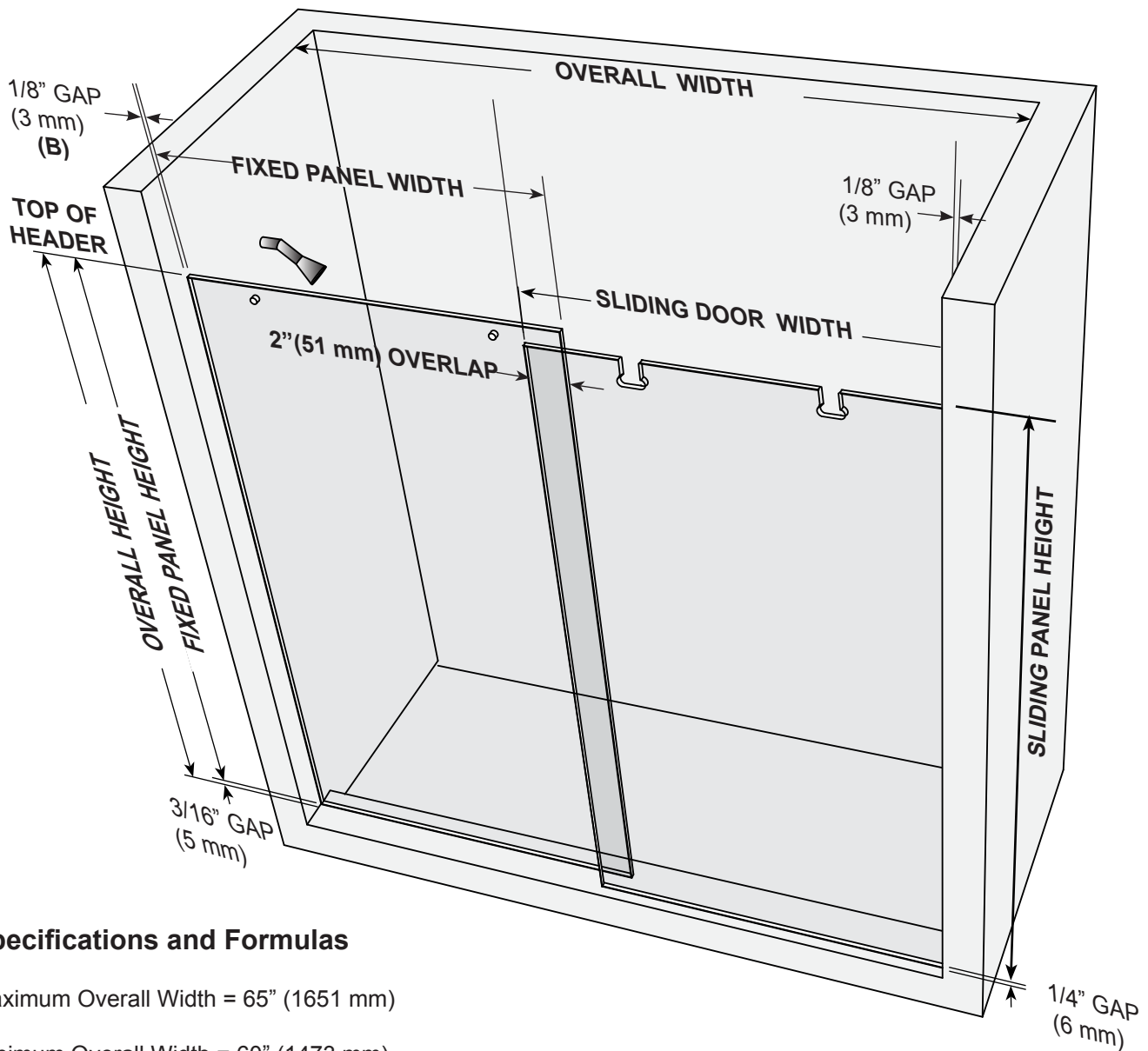

Specifications and Formulas

Maximum Overall Width = 65" (1651 mm)

Minimum Overall Width = 60" (1473 mm)

Metal Header Cut Length = Overall Width minus 5/8" (16 mm)

Fixed Panel Width:

For openings 60" up to 63" (1473 up to 1600 mm): Overall Width minus 30-1/2" (775 mm)

For openings over 63" to 65" (1600 to 1651 mm): Overall Width plus 1-3/4" (45 mm) divided by 2

Fixed Panel Height = Overall Height minus 3/16" (5 mm). Panel is flush with top of the Header Track

Sliding Door Width:

For openings 60" up to 63" (1473 up to 1600 mm): 32-5/16" (821 mm)

For openings over 63" to 65" (1600 to 1651 mm): Overall Width plus 1-3/4" (45 mm) divided by 2

Sliding Door Height = Overall Height minus 2-1/16" (52 mm)

GLASS FABRICATION

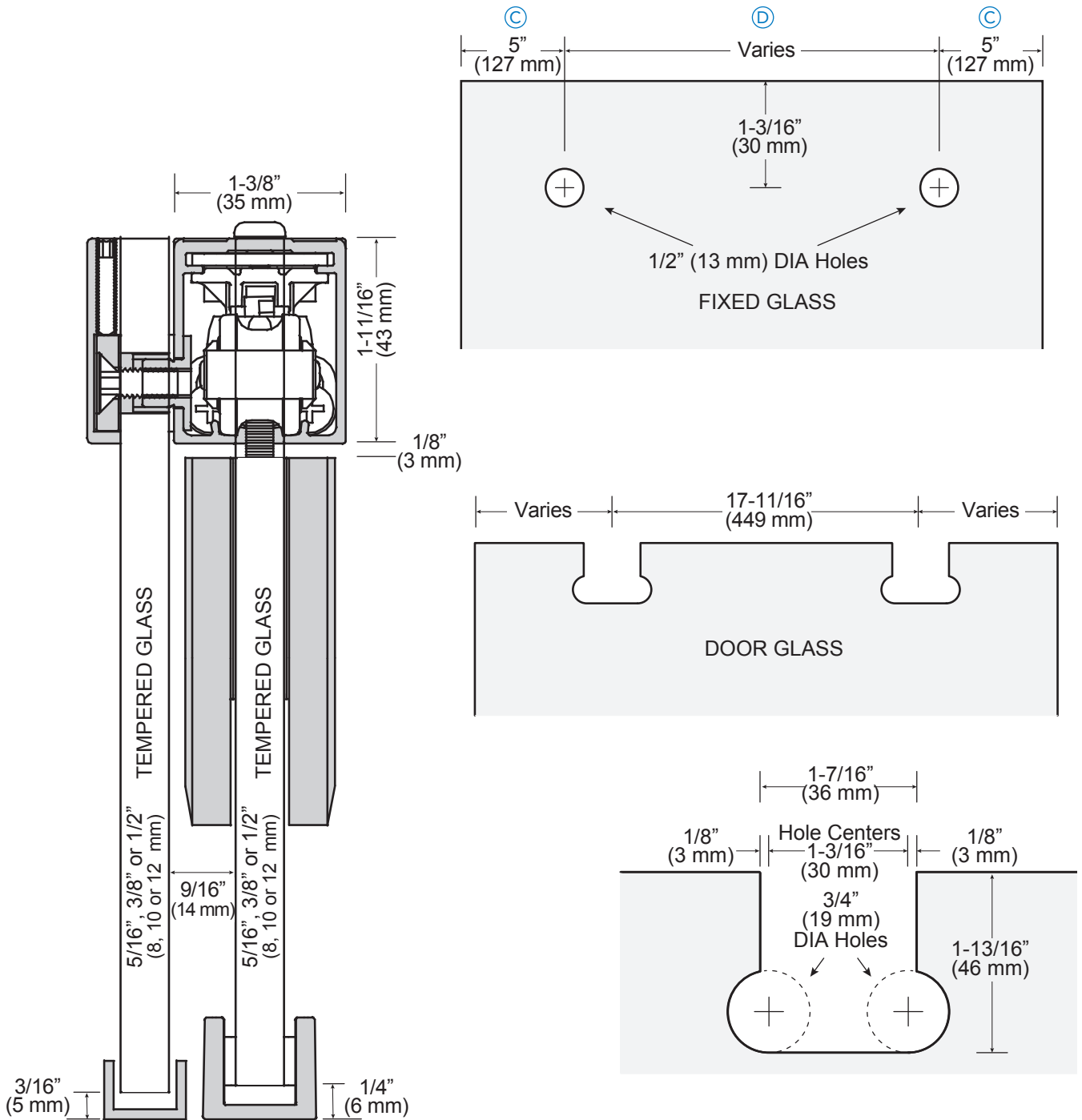

PARTS LIST

This kit includes the following components:

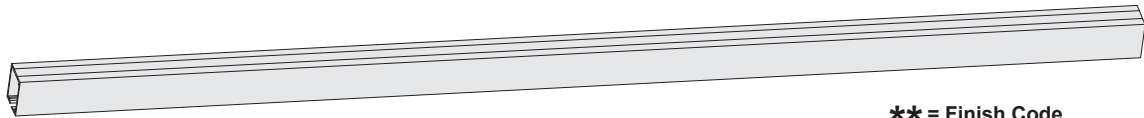
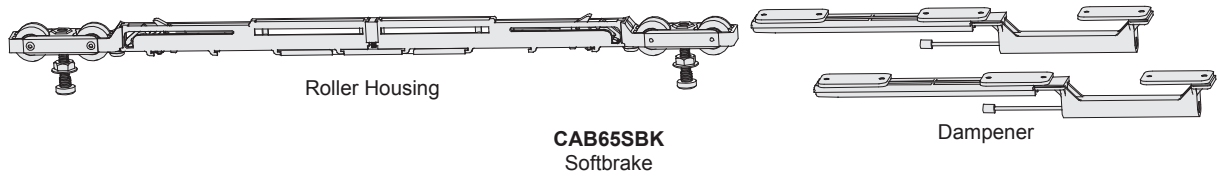

** = Finish Code

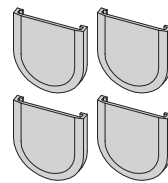
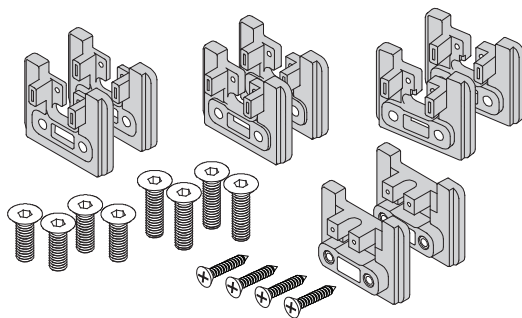

← OR →

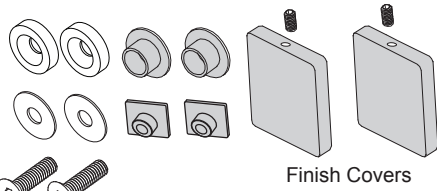
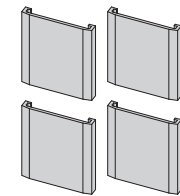

Finish Covers

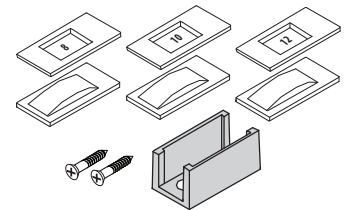
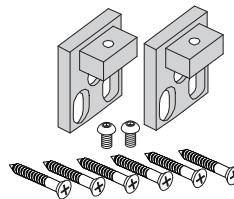

NECESSARY TOOLS

(Not included except for Wrench)

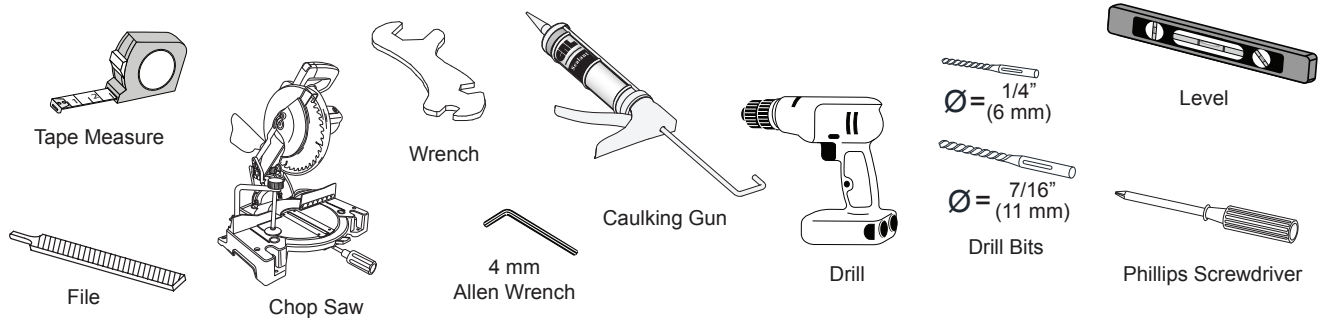

IMPORTANT: READ THIS MANUAL THOROUGHLY BEFORE BEGINNING INSTALLATION.

Cut and Drill Header Track

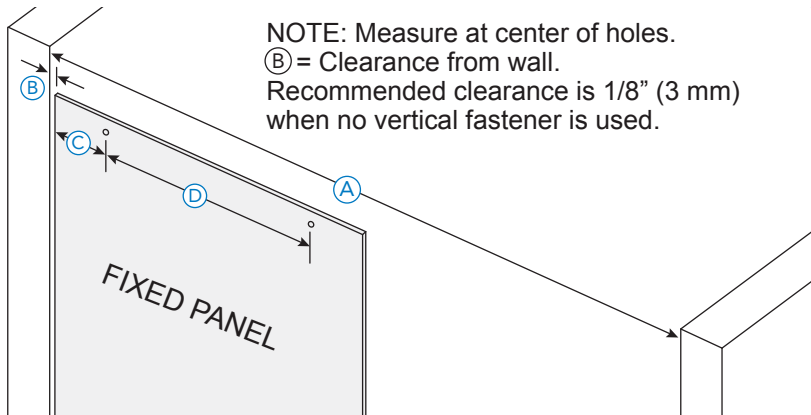

1. Cut Header Track to 5/8" (16 mm) shorter than wall-to-wall tight dimension.

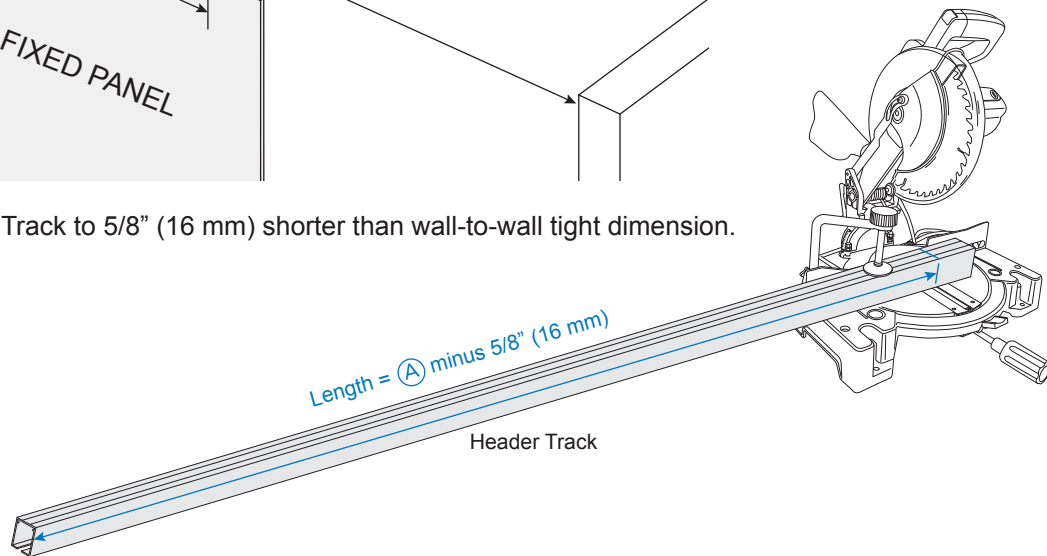

2. Drill 1/4" (6 mm) diameter hole 1/4" (6 mm) from end on top of Header Track at center on BOTH ends.

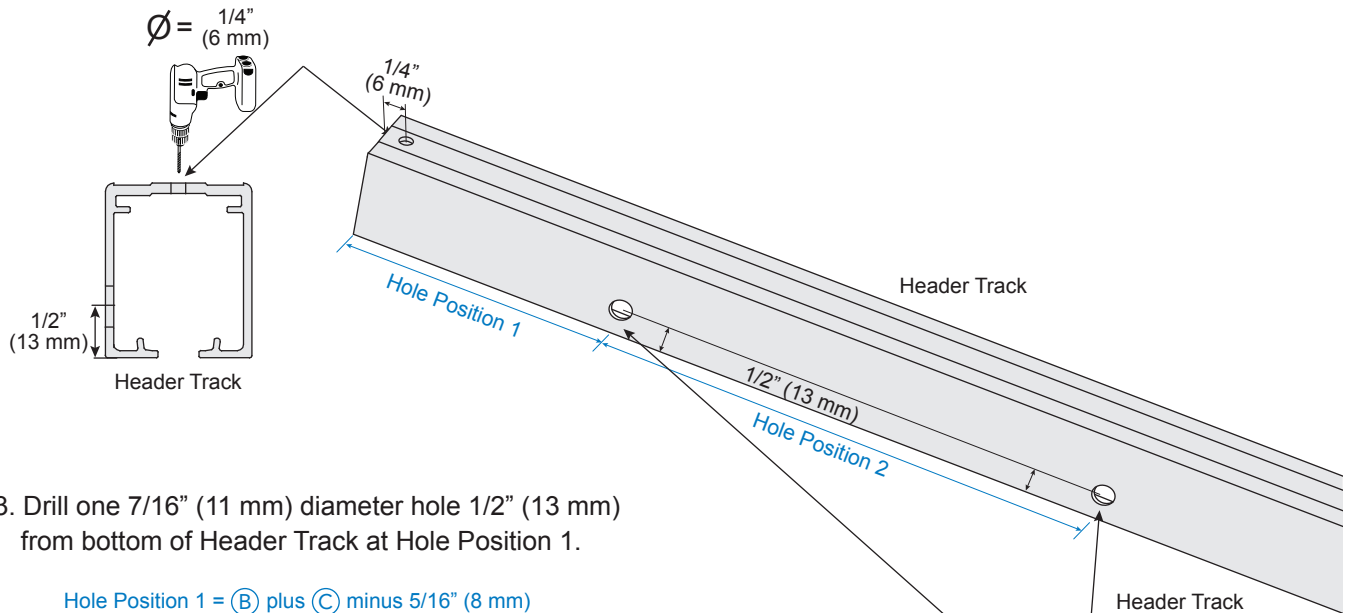

3. Drill one 7/16" (11 mm) diameter hole 1/2" (13 mm) from bottom of Header Track at Hole Position 1.

Hole Position 1 = B plus C minus 5/16" (8 mm)

4. Drill one 7/16" (11 mm) diameter hole 1/2" (13 mm) from bottom of Header Track at Hole Position 2.

Hole Position 2 = Hole Position 1 plus D

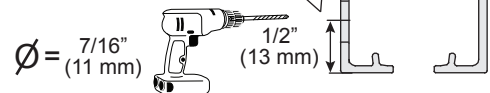

Assemble Header Track

1. Fit Square Threaded Collar Nuts (CAB10) into holes from inside the Header.

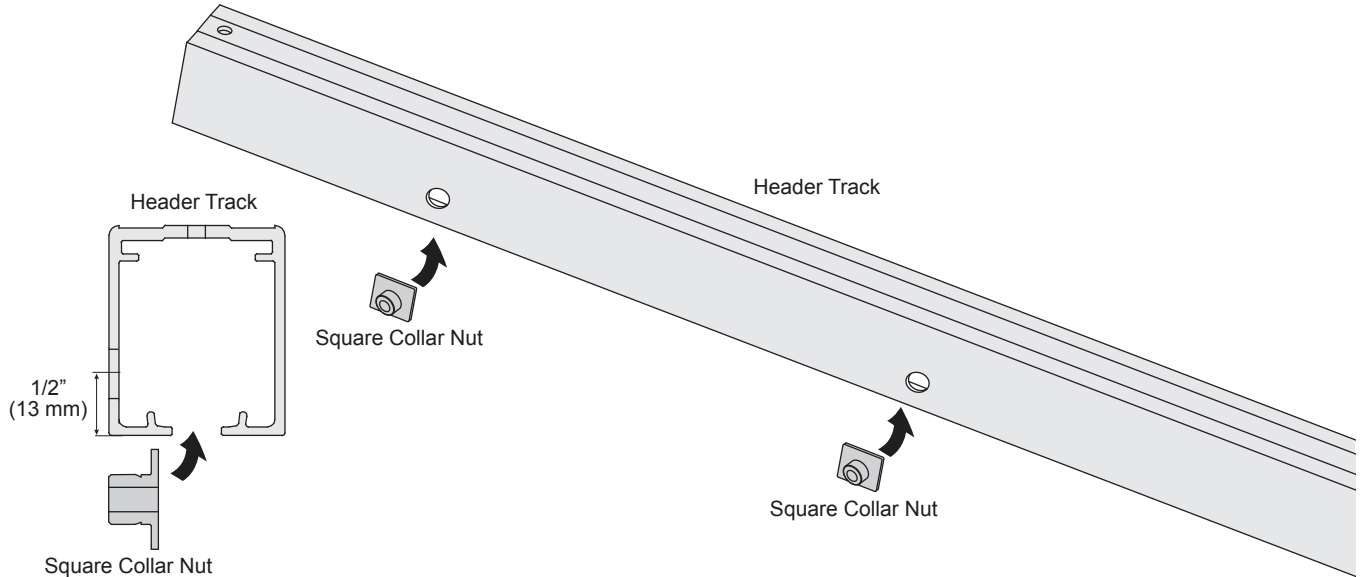

2. Fit white Plastic Collar over Square Nut from outside Header Track and snap into place.

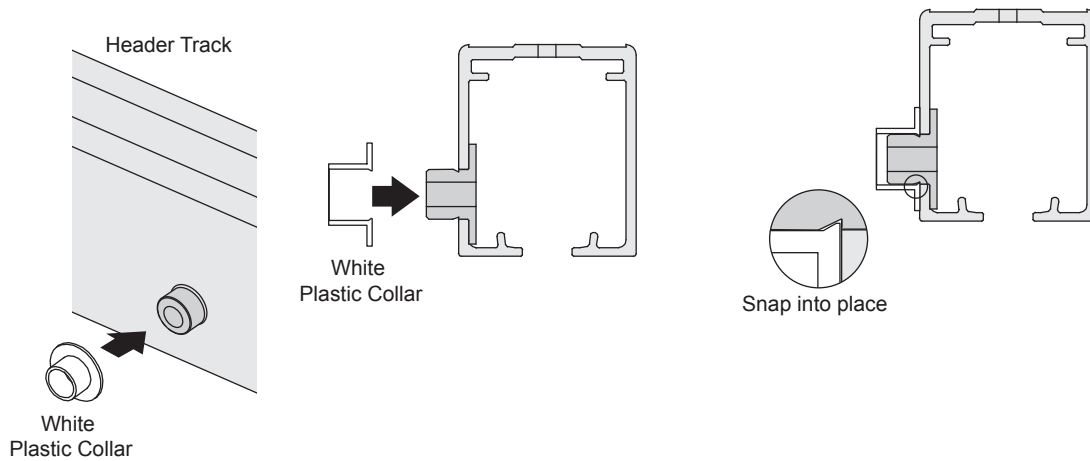

Install Wall Mount Brackets

1. Mark and drill holes for Wall Mount Bracket (CAB11) next to Fixed Glass. Ensure bracket is even with glass at top.

2. Mount with included screws. Mount the other Wall Mount Bracket directly opposite.

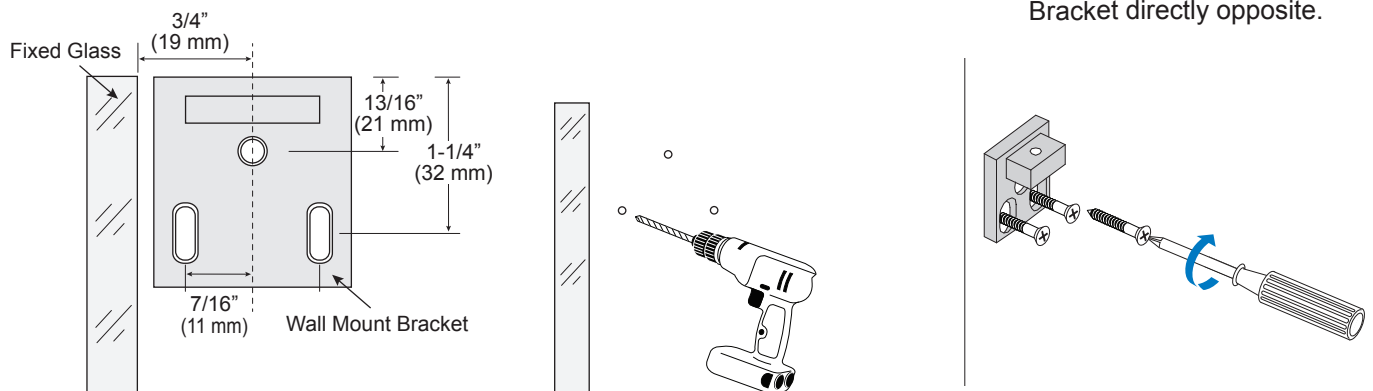

Prepare and Install Softbrake

1. Adjust position of bolt assembly on both sides of Roller Housing.

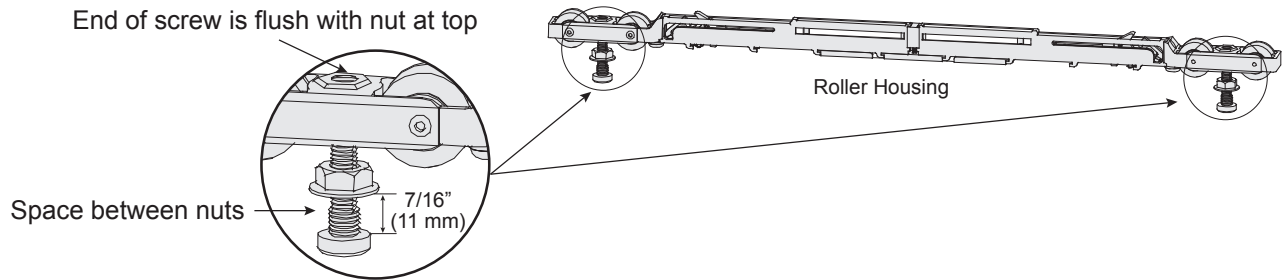

2. Loosen screws on metal plates on top of Dampeners so they can slide into grooves at top of Header Track.

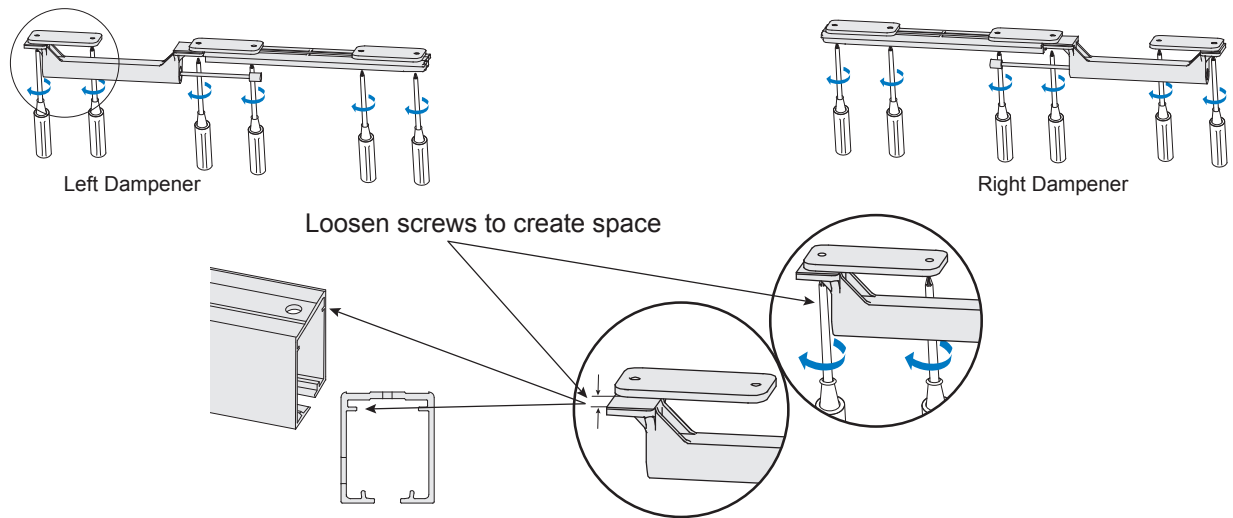

3. Slide Roller Housing into Header Track.

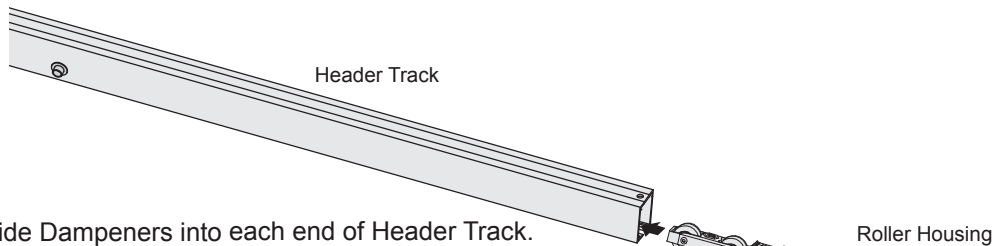

4. Slide Dampeners into each end of Header Track.

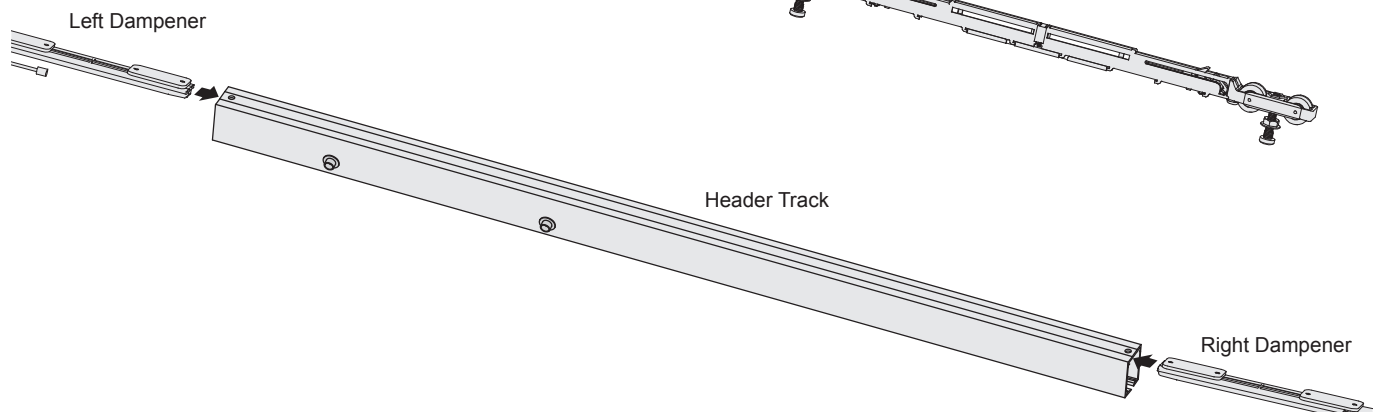

Install Header Track

1. Slide the open bottom of the Header Track onto the Wall Mount Bracket. Rotate the track to upright and secure.

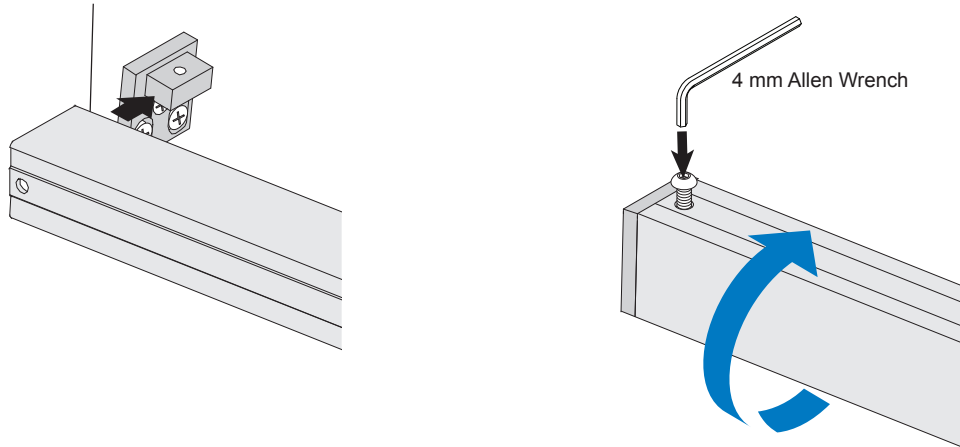

2. Install U-Channel or Glass Clamps (not included) to mount Fixed Panel to the curb.
3. Mount Fixed Panel to curb and position so holes at top line up with the Plastic Collars. Secure to Header Track.

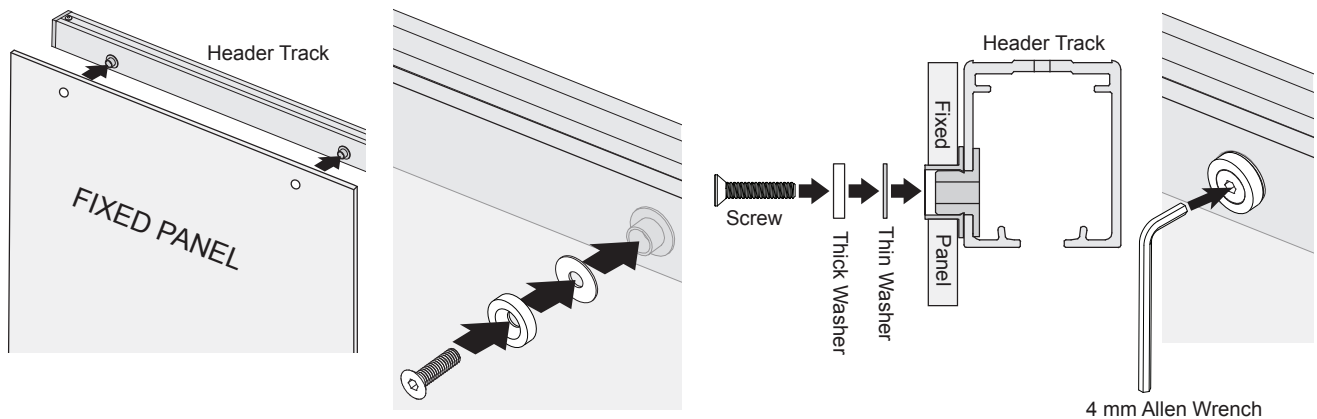

Install Bottom Guide

1. Select plastic insert that matches glass door thickness and slide into Bottom Guide.
2. Use included screws to install on curb. Leave 9/16" (14 mm) gap between glass panels.

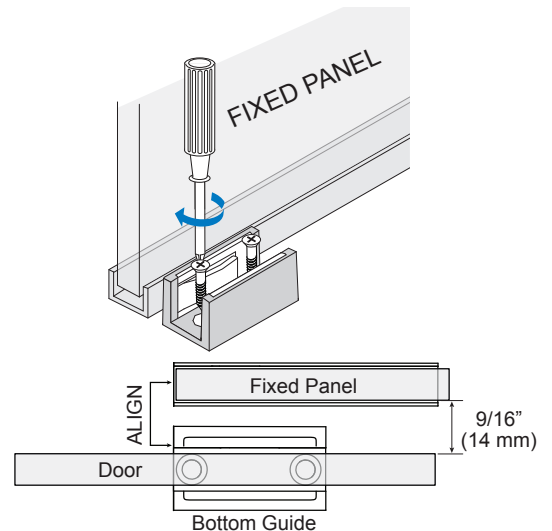
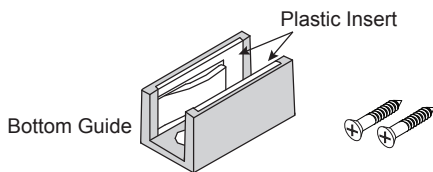
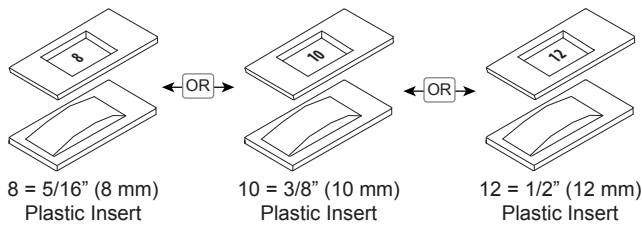

Install Sliding Panel

1. Select Interior Roller Brackets and screws that match the door glass thickness.

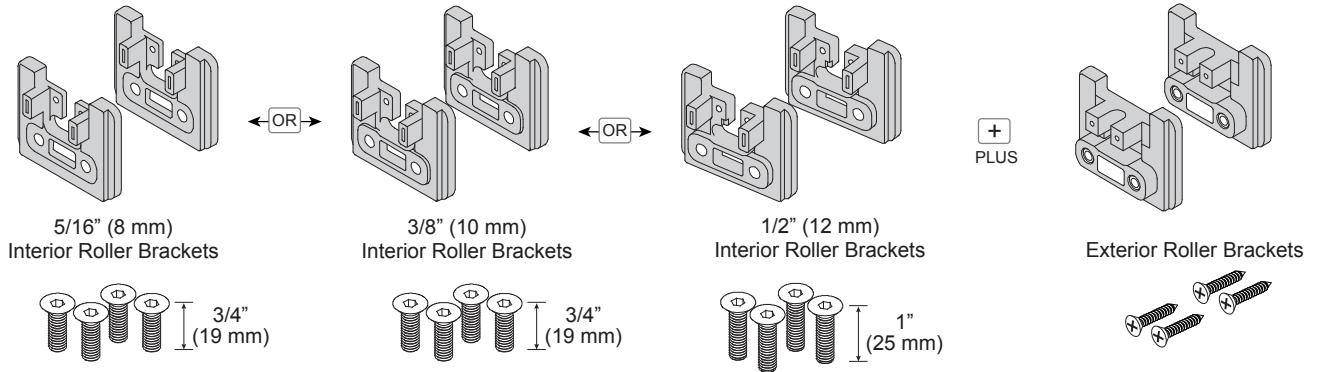

2. Determine Glass Door position relative to Fixed Panel before installation.

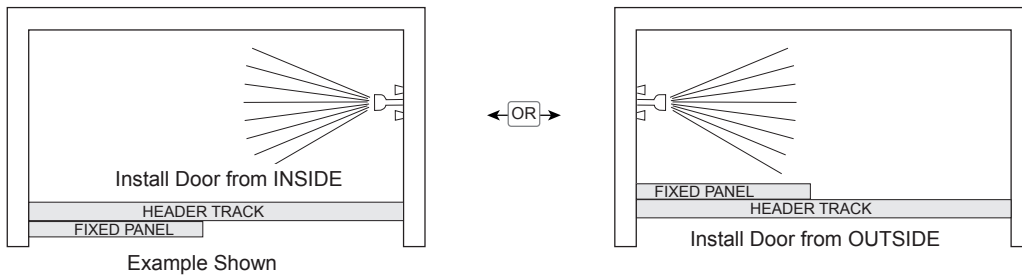

3. Fit each Exterior Roller Bracket onto Roller Housing Bolt Assembly.

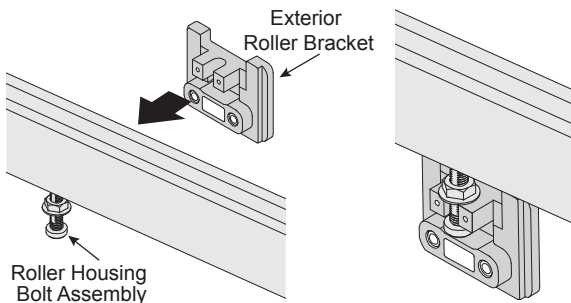

4. Place Glass Door on Wooden Shims to maintain 1/4" (6 mm) gap at bottom. Align notches in top of glass with Roller Brackets. Adjust height to fit.
NOTE: Ensure panel is inside Bottom Guide.

5. Fit each Interior Roller Bracket and secure.

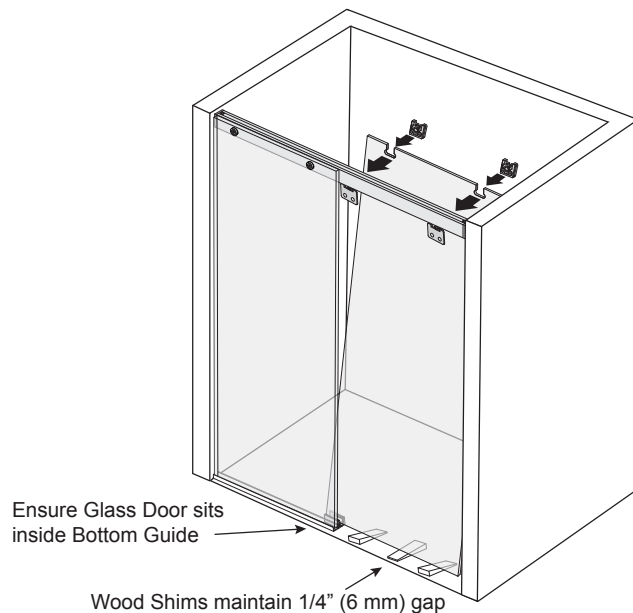
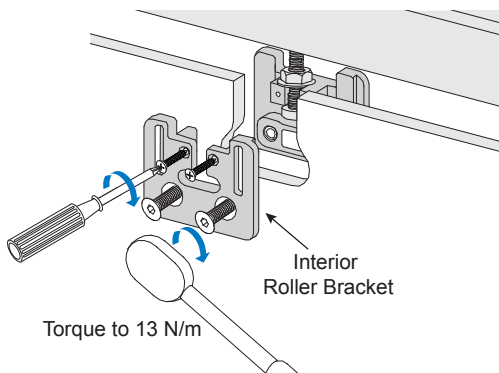

Adjust Sliding Panel

1. Remove the shims and check door alignment.

NOTE: Adjust height using the screw in bolt assembly only. Do not loosen screws in Glass Bracket.

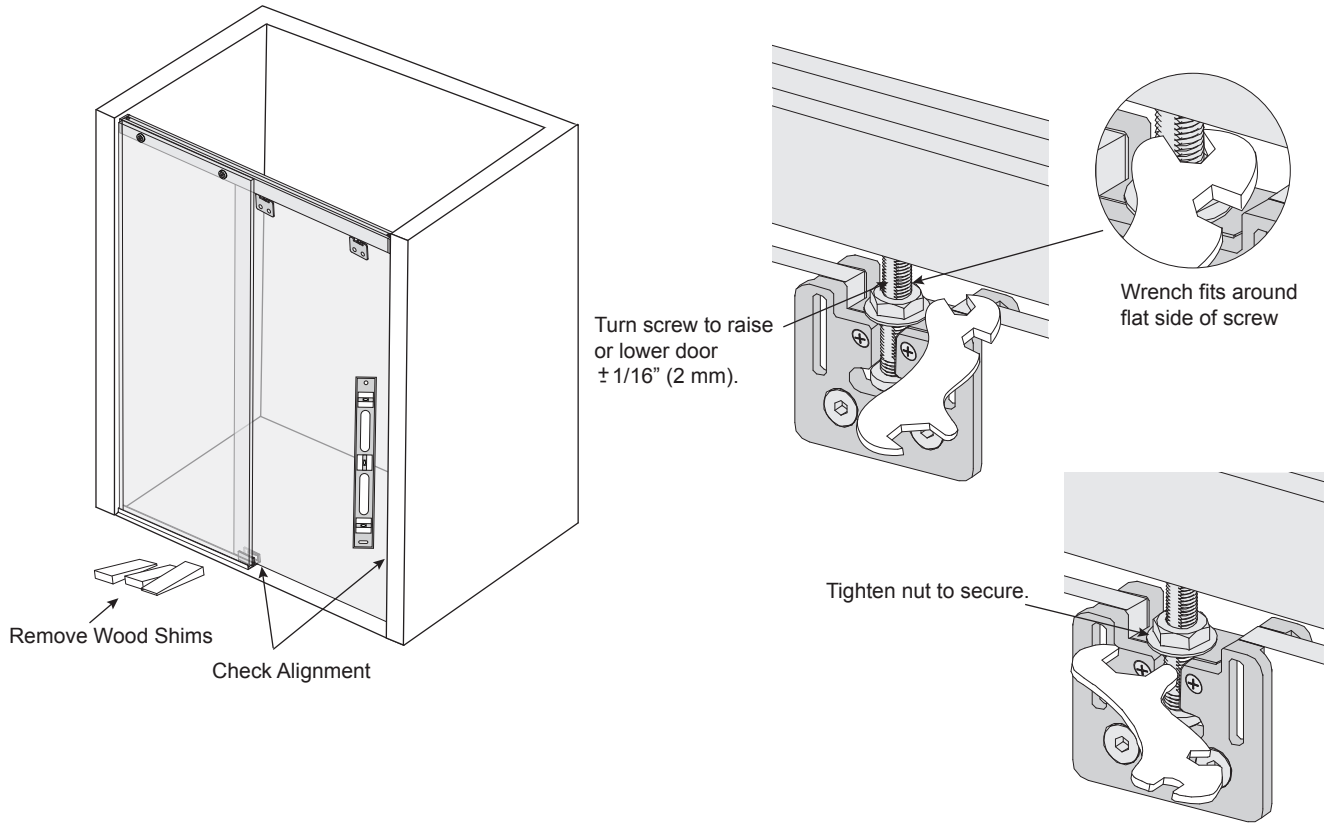

2. Adjust position of Dampeners and tighten screws to secure.

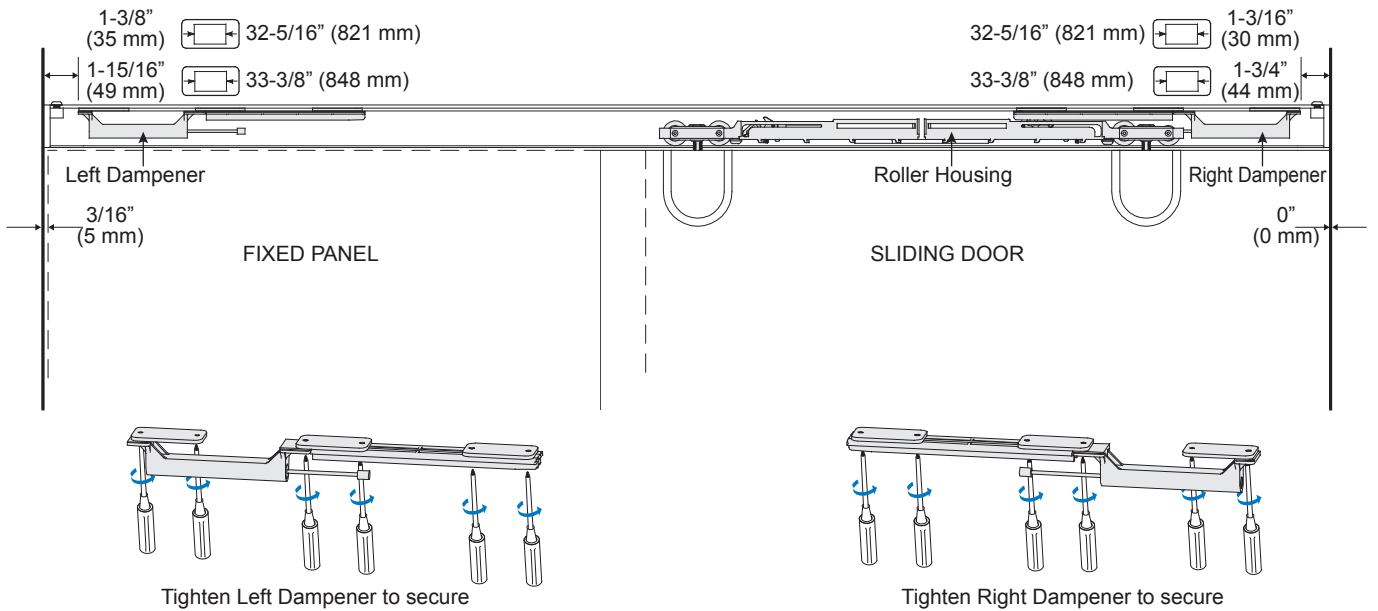

Finishing

1. Install handle (not supplied) and test the closing action of the door. Adjust if necessary.
2. Slide Square or Rounded Roller Bracket Covers into place.

NOTE: Rounded Cover shown.

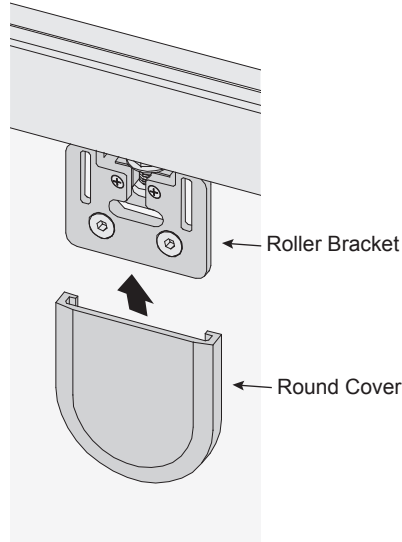

3. With set screw facing up, fit Finish Covers on Fixed Panel Brackets and secure.

