



Series 6000 Thermal MultiPlane— 2" x 6" front set and center set storefront system by Oldcastle BuildingEnvelope®

The Series 6000 Thermal MultiPlane extends the versatility of standard storefront systems by offering **improved thermal and structural performance** with Front Set and Center Set glass plane options. Corner mullions and an optional Front Set SSG mullion with continuous head and sill members offer options to fit many applications. Intermediate horizontals from Series 3000 Thermal MultiPlane (4-1/2" depth) can be used on both Front Set and Center Set configurations to allow for full length blinds or value engineering. Designed for 1" infill, the Series 6000 Thermal MultiPlane has available glazing adapters and gasket options for infills ranging from 1/4" to 1-1/8".



Osprey Pointe, Port of Pasco Headquarters, Pasco, WA
Architect: BCRA, Inc.

Features

- Overall system dimensions: 2" x 6"
- Front Set and Center Set configuration with screw spline assembly
- Thermally broken head anchor clip for Center Set configuration
- SSG glazing option with patented funnel bridge and continuous head and sill assembly for Front Set
- Outside and inside glazing options for Front Set; outside glazing for Center Set
- Complete 90° corner mullions
- Thermally broken members with polyurethane thermal breaks
- Accommodates ZS-2750 vents
- Factory painted Kynar 500®/Hylar 5000® finishes, meeting all provisions of AAMA 2605
- Factory anodized finishing

Details

Front Set

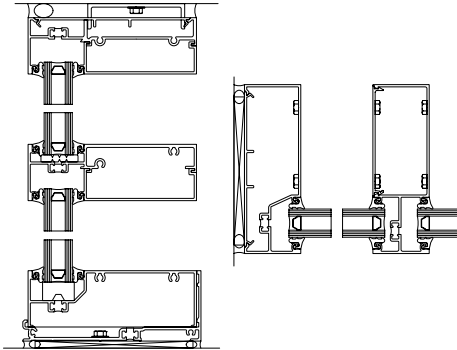

Front Set SSG

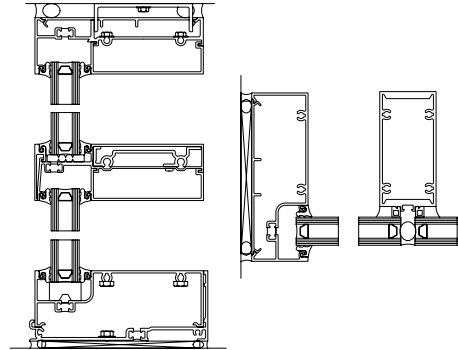

Center Set

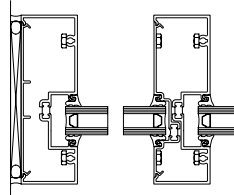
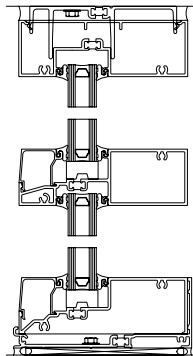

Performance

- Air Infiltration: <.06 CFM/SQ FT (6.24 PSF) per ASTM E283
- Static Water: 10 PSF per ASTM E331
- Thermal Performance per AAMA 1503 for clear 1" insulating glass:
 - Front Set:
 - U-factor = 0.56
 - CRF = 70
 - Center Set:
 - U-factor = 0.59
 - CRF = 61
- Thermal Performance per AAMA 1503 for clear Low-E insulating glass:
 - Front Set:
 - U-factor = 0.34
 - CRF = 73
 - Center Set:
 - U-factor = 0.34
 - CRF = 70
- NFRC Certified
- Thermal Performance Characteristics per AAMA 507