



MSD-375/WSD-500 StormMax[®] entrance

installation & glazing manual

NOTE

THE INSTALLATION DETAILS FOUND IN THIS PACKAGE ARE GENERIC AND ARE FOR REPRESENTATION ONLY WITH THE INTENT OF GIVING THE INSTALLATION TEAM A VISUAL REPRESENTATION AS TO HOW THE ASSEMBLIES TYPICALLY INSTALL. THE SHOP SUBMISSION DRAWINGS AND DETAILS ARE THE GOVERNING DOCUMENTS AND AS SUCH THIS PACKAGE IS TO BE USED ONLY AS A RESOURCE.

FOLLOW SEALANT MANUFACTURERS' RECOMMENDATIONS FOR USE AND APPLICATION OF ALL STRUCTURAL SILICONE SEALANT AND WEATHER SEAL SILICONE SEALANT.

CUSTOMER / PROJECT QUALITY ASSURANCE PROCEDURES ARE SEPARATE DOCUMENTS AND ARE TO BE FOLLOWED IN CONJUNCTION WITH THIS MANUAL.

MSD-375/WSD-500 StormMax® Entrance Installation and Glazing Manual

Table of Contents

IMPORTANT NOTICE	4
GENERAL INFORMATION	4
INSTALLER QUALIFICATIONS	4
ENGINEERING DISCLAIMER	4
BUILDING CODES	4
STRUCTURAL SEALANTS	4
PERIMETER SEALANTS.....	5
MATERIAL AND WORK ACCEPTANCE.....	5
MATERIAL HANDLING.....	6
CLEANING.....	6
GENERAL CONSTRUCTION NOTES.....	6
WARRANTY	7
MAINTENANCE RECOMMENDATIONS	7
WARNING.....	7
Lubrication	7
Door Closer	7
Exit Device	7
PRODUCT OVERVIEW	8
Hardware Locations.....	8
Door Handing	8
MATERIAL INSPECTION	8
Inspect Door Materials Upon Receipt	8
SITE CONDITIONS	12
Review and Prepare Opening	12
Floor Slab Slope Guidelines	12
FRAME FABRICATION	13
1.0 Establish Material Size.....	13
1.1 MSD-375/WSD-500 StormMax® Entrance As Standalone.....	14
1.2 MSD-375/WSD-500 StormMax® Entrance in StormMax® Storefronts	16
1.3 MSD-375/WSD-500 StormMax® Entrance in Curtain Walls.....	17
1.4 Door Stop Lengths	18
2.0 Preparation of Door Frame for Installation.....	19
2.1 Preparation of Door Frame with FG-5700 StormMax® Framing.....	19
2.2 Preparation of Door Frame with FG-5750 or FG-5750T StormMax® Framing.....	20
2.3 Preparation of Curtain Wall Header Subframes.....	21
2.4 Preparation of Storefront Frame or Curtain Wall Subframe for Threshold.....	21
2.5 Reinforcement Fabrication and Attachment for FG-5713 Door Jamb.....	21
FRAME ASSEMBLY	22
3.0 Assembling Door Frame with FG-5700 StormMax® Storefront.....	22
4.0 Assembling Door Frame with FG-5750 or FG-5750T StormMax® Storefront Framing.....	26
5.0 Assembling Door Subframes for StormMax® Curtain Walls	28
6.0 Attaching Threshold to Frames/Subframes	29
FRAME INSTALLATION	30
7.0 Installing Door Frame at FG-5700/FG-5750 StormMax® without Sidelite	30
8.0 Installing Door Frame in FG-5700/FG-5750/FG-5750T StormMax® with Sidelite.....	33
9.0 Installing Door Subframe at StormMax® Curtain Walls	34
10.0 Installing Door Stops.....	37
10.1 FG-5163 Door Stop	37
10.2 FG-5222 with FG-5223 Two-Piece Door Stop	38
10.3 DS-104 with SC-1 Spring Clip.....	40
11.0 Installing Transom Sash	41

MSD-375/WSD-500 StormMax® Entrance Installation and Glazing Manual

GLAZING	42
12.0 Glass Sizing	42
12.1 Door Glass Sizing	42
12.2 Transom Glass Sizing	43
13.0 Glazing the Door	45
13.1 Glazing Practices	45
13.2 Preparing Door for Glazing	46
13.3 Cut Gasket to Length	47
13.4 Setting Glass	47
13.5 Application of Structural Sealant	48
14.0 Transom Glazing	49
14.1 Preparing and Installing Interior Gasket	50
14.2 Setting Glass and Installing Exterior FG-5730 Gaskets	51
14.3 Application of Interior Structural Sealant	54
HANGING THE DOOR	55
15.0 Hanging Butt Hinge Door	55
16.0 Hanging Offset Pivot Door	56
17.0 Hanging Gear Hinge Door	57
18.0 Installing Hardware	58
18.1 Closers	58
18.2 Panics	58
18.3 Other Hardware	58
Final Adjustments to Door	59
PARTS LIST	60
FG-5700 StormMax® Framing	60
FG-5750 StormMax® and FG-5750T StormMax® Framing	60
Common Framing Members	61
StormMax® Curtain Wall Subframe Members	62
Door and Door Extrusions	62
Gaskets	62
Accessories	63
Fasteners	64

MSD-375/WSD-500 StormMax® Entrance Installation and Glazing Manual

IMPORTANT NOTICE

Completely read these instructions prior to beginning work. These recommendations are for general erection/installation procedures only. For actual job conditions, see shop drawings if applicable. For perimeter anchor types and spacing, refer to the approved shop drawings or consult structural engineer/project design professional.

GENERAL INFORMATION

Oldcastle BuildingEnvelope®'s MSD-375/WSD-500 StormMax® impact resistant entrance system represents the latest in product development technology. This system was especially designed to meet the stringent requirements of the Florida Building Code in the High Velocity Hurricane Zone (HVHZ) as well as the International Building Code for glass and glazing systems. The MSD-375/WSD-500 StormMax® entrance and framing passed a series of large missile impact and cyclic wind tests with a variety of impact-resistant glass.

INSTALLER QUALIFICATIONS

These architectural framing systems are intended for fabrication, assembly, sealing, installation and glazing by professionals with appropriate knowledge and experience of the system(s) and their incorporation into various building conditions.

ENGINEERING DISCLAIMER

Each customer, whether directly or through the professional engineering expertise of its own engineer or that of the engineer of record, assumes all liability for determining the applicability of the appropriate state building code for each project.

BUILDING CODES

Oldcastle BuildingEnvelope® does not control the application nor selection of its product configurations, sealant, or glazing materials, and assumes no responsibility thereof. It is the responsibility of the owner, architect, and installer to make these selections in strict compliance with applicable laws and building codes.

STRUCTURAL SEALANTS

DOWSIL™ 995 Silicone Structural Sealant was used on the MSD-375/WSD-500 StormMax® entrance and framing test specimens for glass to metal adhesion. **Tremco® Proglaze® II** is approved for use as an alternate. To comply with the Florida Building Code protocols, one of these two sealant products must be used for glass to metal adhesion.

The fabrication and installation of a structural silicone-glazed (SSG) or wet glazed system requires more technical knowledge and experience than is required for a conventional pressure-glazed or dry glazed system. The glazing contractor should take all steps as outlined and required by the structural silicone sealant manufacturer, glass fabricator, framing manufacturer, and the project professional engineer of record as well as follow local building code requirements and industry best practices to ensure the proper installation and safe performance of the SSG system.

The glazing contractor for each project needs to ensure compliance with each step, including, but not limited to, design reviews, formal adhesion testing, formal compatibility testing, project specification compliance, validating procedures, field testing, and quality control validation of installed product and surrounding conditions.

Testing of component materials for use in a SSG or wet glazed system is mandatory to fulfill project specifications and warranty requirements and must be submitted by the glazing contractor to the structural silicone manufacturer. All materials that comprise the structural silicone joint, such as the framing system (with the job-specific finish) and job-specific glass must be tested by the structural silicone manufacturer for compatibility and adhesion. All other accessory materials in contact with the structural silicone, such as setting blocks, spacers, gaskets, sweeps, air seals and expansion joints, must also be submitted to the silicone sealant manufacturer for compatibility testing.

1-866-OLDCASTLE (653-2278)

OBE.com

Version: 2024-0805

Copyright © 2022 Oldcastle BuildingEnvelope®
All rights reserved.

™ ® Trademarks of Oldcastle BuildingEnvelope and its affiliated companies or respective owners.

MSD-375/WSD-500 StormMax® Entrance Installation and Glazing Manual

To ensure that nothing has changed in formulation or chemistry since the initial tests, subsequent testing during periodic time frames of the project is to be conducted to confirm continued acceptance of the material for use on the project.

To ensure the structural performance and integrity of the insulating glass unit (IGU), the glazing contractor must submit the project shop drawings to the glass fabricator to obtain approval for use of their product(s) in any 2, 3 or 4-sided SSG applications.

Quality control procedures for field glazing are to be increased beyond those required for shop glazing. Job conditions will normally have dust, dirt, and other construction debris on the surfaces where structural silicone is to be applied. Great care should be exercised in cleaning and preparing these surfaces for silicone application. The recommendations of the silicone sealant manufacturer are to be strictly enforced and followed. The fabrication and installation of the SSG system and its components, whether shop or field glazed, should be governed by a quality control program, and all steps, procedures, and test reports should be documented throughout the project.

Prior to installation of any SSG system, refer to industry documents (e.g., AAMA Curtain Wall Design Guide Manual, ASTM C1401-14, and AAMA SSGDG-17) for detailed instructions and recommendations.

THE GLAZING CONTRACTOR ASSUMES FULL RESPONSIBILITY FOR ENSURING COMPLIANCE WITH THE ABOVE AND ASSUMES FULL LIABILITY FOR ANY ISSUES ARISING FROM NONCOMPLIANCE.

PERIMETER SEALANTS

Due to varying job conditions, all perimeter and weather sealants used should be approved by the sealant manufacturer to ensure the sealant will function for the conditions shown on these instructions and shop drawings. Sealants must be compatible with all surfaces where adhesion is required, including other sealant surfaces. Use primers where directed by sealant manufacturer. Be sure to properly store sealants at recommended temperature and check container for remainder of shelf life before using. Either **DOWSIL™ 795** or **Tremco® Dymonic® 100** is recommended for non-structural seals.

MATERIAL AND WORK ACCEPTANCE

OLDCASTLE BUILDINGENVELOPE® MATERIALS

Check all material upon arrival for quality and to assure against shipping damage. Any visible damage must be noted on the freight bill at the time of receipt. If a claim is required, then the receiving party must process a claim with the freight company.

OTHER TRADES WORK

Completely check construction that will receive your materials against contract documents. Notify general contractor by letter of any discrepancies before proceeding with work. Failure to do so constitutes acceptance of work by other trades.

MSD-375/WSD-500 StormMax® Entrance Installation and Glazing Manual

MATERIAL HANDLING

Handle the material carefully. Do not drop from the truck. Stack with adequate separation so that the material will not rub together. Store material off the ground. Protect against the elements and other construction hazards by using a well-ventilated covering away from other trades. Remove material from package if it is wet or located in a damp area.

SHOP

- Cardboard wrapped or paper interleaved material must be kept dry. Immediately remove aluminum from cardboard or paper interleaved materials should it get wet to prevent staining or etching the aluminum finish.
- Check arriving materials for quantity and keep record of where various materials are stored.

JOB SITE

- Material at job site must be stored in a safe place well removed from possible damage by other trades.
- Cardboard wrapped or paper interleaved materials must be kept dry.
- Keep record of where various materials are stored.
- Protect materials after erection. Cement, plaster, and other alkaline solutions are very harmful to the finish.

EXPANSION JOINTS

Expansion joints and perimeter seals shown in these instructions and in the shop drawings are shown at standard size. Actual dimensions may vary due to perimeter conditions and/or differences in metal temperature between the time of fabrication and time of installation. For example, a 12-foot unrestrained length of aluminum extrusion can expand or contract 3/32 of an inch over a 50-degree Fahrenheit change. Any movement potential should be accounted for at time of the installation.

GLASS

Glazing gaskets are designed for a compression fit against glass and can accommodate (+/- 1/32"). Be sure to check overall glass size and thickness.

CLEANING

Final cleaning of exposed aluminum surfaces should be done in accordance with AAMA 609.1 for anodized aluminum and AAMA 610.1 for painted aluminum. Cement, plaster, terrazzo, alkaline and acid-based materials used to clean masonry are very harmful to finishes and should be removed immediately or permanent staining will occur. A spot test is recommended before any cleaning agent is used. Aluminum shall be cleaned with plain water containing a mild detergent or a petroleum product, such as white gasoline, kerosene, or distillate. No abrasive agent shall be used.

GENERAL CONSTRUCTION NOTES

- A. Study these instructions, shop drawings, erection drawings, and architectural drawings before starting any work. Follow installation and glazing instructions.
- B. Completely check construction which will receive your materials against contract documents. Notify the general contractor by letter of any discrepancies before proceeding with your work since this constitutes acceptance of work by other trades.
- C. Coordinate protection of installed materials with general contractors and other trades.
- D. Do not install wall if there is a walkway with a downslope towards an entrance or a storefront.
- E. All materials are to be installed plumb and level.
- F. All work should start from an established benchmark and column centerlines established by the architect and the general contractor.
- G. Protect all aluminum to be placed directly in contact with uncured masonry or incompatible materials with a heavy coat of bituminous paint.

MSD-375/WSD-500 StormMax® Entrance Installation and Glazing Manual

WARRANTY

A standard limited warranty for the MSD-375/WSD-500 StormMax® entrance covers approved installation and standard product sizing. Obtain a copy of the product warranty for the approved jobsite from an Oldcastle BuildingEnvelope® sales representative. Warranty does not cover MSD-375/WSD-500 StormMax® entrances installed with unapproved or untested hardware.

MAINTENANCE RECOMMENDATIONS

Proper maintenance of the door and door hardware will ensure continued functionality. Failure to upkeep regular maintenance may result in loss of function and/or void warranty. Follow all maintenance guidelines provided.

WARNING

Chemicals used to melt ice should not make contact with aluminum Threshold, bottom of door Jambs or pivot hardware. These chemicals are very corrosive and may cause door failure and possible personal injury.

Lubrication

Every 3-4 weeks, the following items should be lubricated with STP Spray Silicone:

- Hinges
- Lock Cylinders

Reference manufacturer's lubrication guide for the following items:

- Exit Device
- Closer Arm

Door Closer

Refer to the maintenance guide included from the manufacturer with the Door Closer for complete maintenance schedule. In general, for proper Door Closer function, the Door Closer should be checked regularly and adjusted accordingly. Refer to the manufacturer's maintenance guide for more information.

- Adjust the Sweep Range as required. Adjustment is made by turning the "S" valve on the back of the closer.
- Adjust the Latch Range as required. Adjustment is made by turning the "L" valve on the back of the closer.
- Adjust the Back Check as required. Adjustment is made by turning the "BC" valve on the back of the closer.
- Tighten all screws as needed on the arm and main unit.

Exit Device

Proper clearances are essential for optimal operation of installed doors, which means the installed panic must be kept well maintained. Refer to the maintenance guide included from the manufacturer with the Exit Device for complete maintenance schedule.

MSD-375/WSD-500 StormMax® Entrance Installation and Glazing Manual

PRODUCT OVERVIEW

Hardware Locations

Hardware locations may change region to region and may be controlled by local codes. Entrances are factory-prepped for some hardware and all details should be verified with site-drawings and codes before ordering.

Door Handing

In order to simplify the entrance ordering process, Oldcastle BuildingEnvelope® utilizes a short identifier that relies on Hinged-Side and Swing Direction as opposed to general Door Handing® practices. To determine which entrance to order, stand on the outer side of the door and look toward the entrance. The outside of the door is the side that faces out of the building or is the weather-sealed side, if the door is not an exterior door. Take note of which side is the hinge side, which direction the door swings, and, for pairs, where the lock cylinder is located. Reference Figure 1 for a visual aid on determining door types and verify the correct MSD-375/WSD-500 StormMax® entrance has been ordered prior to fabricating framing members and installing the door.

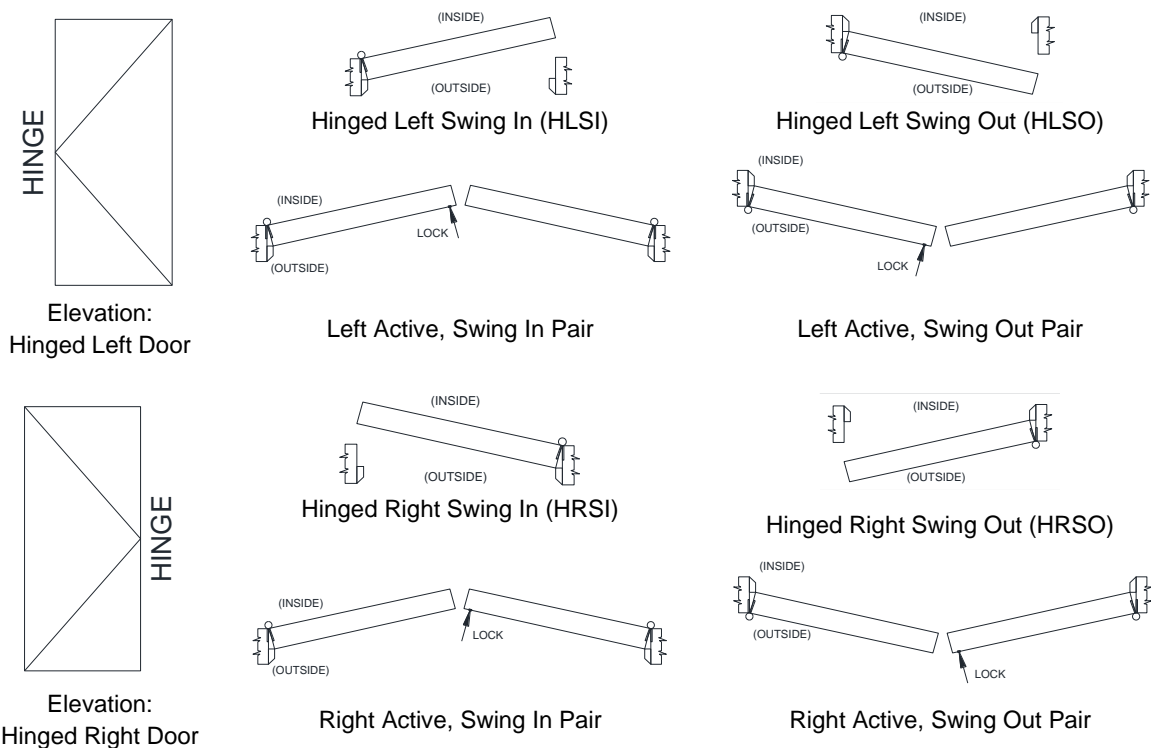

Figure 1: Door Identification Guide

MATERIAL INSPECTION

Inspect Door Materials Upon Receipt

Inspect all materials upon receipt to be sure that all items have been received and that no damage has occurred. If there is damage that is clearly due to improper handling or transit, it is up to the customer to settle claims with the freight company. If there is damage or missing/incorrect items due to Oldcastle BuildingEnvelope® error, notify your sales representative or Oldcastle BuildingEnvelope® within 7 days.

The following items are shipped in the **Door Box**:

- Assembled Door
 - Butt Hinges **or** Offset Pivots **or** Gear Hinges (installed on door)
 - Cylinder (installed in door)
 - Exit Device (installed on door **or** Door fabricated to customer provided template)
 - Glass Stops (taped in place)

MSD-375/WSD-500 StormMax® Entrance Installation and Glazing Manual

- A smaller box containing:
 - Pull Handle

The following items are shipped in the **Frame Box**:

- Door Jamb
 - FG-5700 StormMax®, FG-5750 StormMax® or FG-5750T StormMax® Storefront Framing:
 - FG-5713 Door Jamb
 - Reliance™ StormMax® or Reliance™ StormMax® High Performance Curtain Wall Subframe:
 - D-226 Jamb Subframe
- Door Header
 - FG-5700 StormMax® Storefront Framing:
 - FG-5766 Door Header (for Surface Closer with or without Transom, FG-5716 required without transom) **or**
 - FG-5765 Door Header (for Concealed Closer with or without Transom)
 - FG-5750 StormMax® or FG-5750T StormMax® Storefront Framing:
 - FG-5765 Door Header (for Concealed Closer with or without Transom) **or**
 - FG-5766 Door Header (for Surface Closer without Transom) **or**
 - FG-5767 Door Header (for Surface Closer with Transom)
 - Reliance™ StormMax® or Reliance™ StormMax® High Performance Curtain Wall Subframe:
 - D-231 Header Subframe (for Surface Closer) **or**
 - FG-5765 Header Subframe (for Concealed Closer)
- Door Stops
 - All StormMax® Storefront or Curtain Wall Products:
 - FG-5163 Stop (Typical) **or**
 - DS-104 Stop (for Concealed Closer Headers) **and/or**
 - FG-5222 Door Stop Base with FG-5223 Door Stop Cover (for Continuous Gear Hinge Jambs)
- Threshold
 - TH-57 Threshold
 - D134-3 Panic Stop
 - TH-60 Anchor or FG5000-FP-19 Anchors

MSD-375/WSD-500 StormMax® Entrance Installation and Glazing Manual

Frame Box *continued:*

- Transom Components
 - FG-5700 StormMax® Framing:
 - FG-5198 Sash
 - FG-5769 Sash Stop
 - HP-17 Setting Blocks (for Surface Closer) **or** FG-5229 Setting Blocks (for Concealed Closer)
 - FG-5700 Transom Head **or** FG-5701 Transom Head with FG-5710 Glass Stop
 - FG-5750 StormMax® and FG-5750T StormMax® Framing:
 - FG-5181 Transom Sash
 - FG-5769 Sash Stop
 - HP-92 Setting Blocks
 - FG-5750 Transom Head **or** FG-5751 Transom Head with FG-5760 Glass Stop
- Screws, Clips, and Gaskets
 - Various Fasteners
 - FG-1133 Entrance Glazing Gasket
 - FG-5188 Entrance Spacer Gasket
 - D-125 Weather Seal Gasket
 - Entrance Setting Blocks:
 - FG5000-PP-1 (for 9/16" infill)
 - D-123 (for 1" infill)

The following items are shipped in separate boxes:

- D-118 Sweep Retainer with D-120 Sweep (if required)
- Surface **or** Concealed Closer

Doors factory installed with the following devices:

- Butt Hinges (Frames factory prepped to match):
 - Regent 4001 Stainless Steel **or**
 - Hager BB1199 Stainless Steel **or**
 - McKinney RC TA2314 Stainless Steel
- Continuous Gear Hinges (Frames must be field prepped):
 - Ives 224 **or**
 - Roton 780-224HD **or**
 - Pemko CFM83SLI HD1
- Offset Pivots (Frames factory prepped to match):
 - Top Pivot
 - OBE OP-6 **or**
 - OBE OP-7
 - Intermediate Pivot
 - Rixson M19
 - Bottom Pivot
 - OBE OP-9 **or**
 - OBE OP-10

MSD-375/WSD-500 StormMax® Entrance Installation and Glazing Manual

MSD-375/WSD-500 StormMax® entrances are compatible with the following Exit Devices (refer to Product Approvals for hardware limitations):

- Rim Panics:
 - Von Duprin 99 with 425-SNB, 9954 Removable Mullion, 299 Strike and 154 Mullion Stabilizer (Wide Stile Entrance only)
 - Sargent AD8500 with HC L980 Removable Mullion and 649 Strike
 - Corbin Russwin ED4200S with WS708AKM Removable Mullion and ED4200S Strike
- Surface Vertical Rod Panics:
 - Von Duprin 9927
- Concealed Vertical Rod Panics:
 - First Choice FL3690
 - Jackson 1285
 - Jackson 2086
 - Regent 5770
 - Sargent AD8410 (optional 106 Aux. Control)
 - Von Duprin 9947

MSD-375/WSD-500 StormMax® entrance may be installed with the following hardware:

- Deadlocks and Flush Bolts:
 - Adams Rite MS 1850 Deadlock (3 point)
 - Adams Rite MS 1850S with 4015 Threshold Bolt, 4016 Header Bolt (3 point) and 41-028 Lock Rod Bracket
 - Adams Rite 2180 Auto Release Flush Bolt (2 point)
 - OBE FB-1201-VRM Flush Bolt
- Adams Rite AR-4089 Lock Indicator (optional)
- Various Surface or Concealed Closers
- Various Push Bars & Pull Handles, including OBE PH-20 and PB-21
- Cylinder (when required)

MSD-375/WSD-500 StormMax® Entrance Installation and Glazing Manual

SITE CONDITIONS

Review and Prepare Opening

Prior to installation of a door and frame, it is important to consider the surrounding construction. If any of the following items are incorrect, contact the appropriate trade or the general contractor (in writing) and request a correction.

- Verify that the opening for the entrance is in the correct location.
- Make sure the opening is large enough to handle the door and frame that was ordered.
- Allow a minimum 1/4" and maximum 1/2" shim space all around the perimeter of the frame.
- Remove any obstructions in the opening.
- Verify there is sufficient structure to anchor the frame.
- Verify the support is properly positioned.
- Verify whether the entrance will be installed with or without a sidelite.
 - If the entrance includes a sidelite condition, review all installation instructions for both the sidelite framing system and the entrance.
- Consult with an engineer or determine if floor anchors are required.
- Verify that the slab is level or sloped away from the building.
- Verify that there is proper clearance to install the Threshold. The MSD-375/WSD-500 StormMax® entrance utilizes a Threshold 5 5/8" wide and 1/2" tall.

If all conditions are acceptable, the MSD-375/WSD-500 StormMax® entrance may be installed.

Floor Slab Slope Guidelines

To ensure proper operation and drainage of water from the face of door, the substrate at the exterior of the door must slope a minimum of 1-degree away from the building. If the substrate slopes towards the building, an outward-swinging door will not open and water will flow into the building.

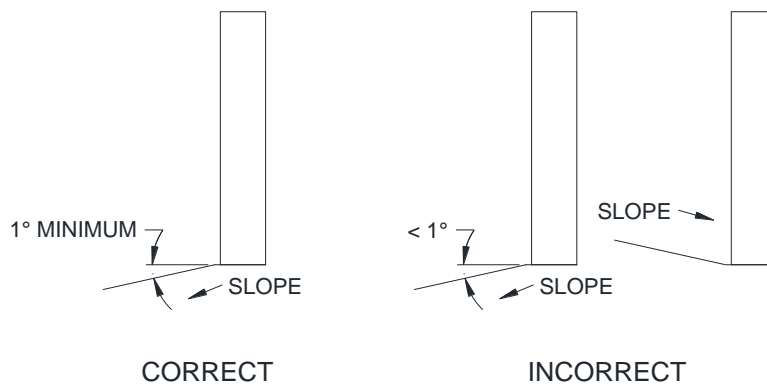

Figure 2: Floor Slab Slope Guide

MSD-375/WSD-500 StormMax® Entrance Installation and Glazing Manual

FRAME FABRICATION

1.0 Establish Material Size

MSD-375/WSD-500 StormMax® entrance can be installed in a variety of configurations. It may be installed as a standalone product, with and without transom and/or sidelites comprised of StormMax® storefront framing or curtain wall Subframe. Though the prep work for each application is similar, follow the fabrication guide for the appropriate situation to ensure the proper fit and function of the entrance.

NOTE: No matter the installation type, the entrance opening must be square and plumb.

For all installation types, when measuring the rough opening, take multiple measurements and use the smallest dimension. This assures a proper fit of the MSD-375/WSD-500 StormMax® entrance system. For the rough opening's width, measure the top, middle, and bottom of the opening. For the rough opening's height, measure the left, center, and right side of the opening.

Measure width of rough opening.

- A. Measure opening at bottom.
- B. Measure opening at center.
- C. Measure opening at top.

Measure height of rough opening.

- A. Measure opening from top to bottom of left side.
- B. Measure opening from top to bottom of middle.
- C. Measure opening from top to bottom of right side.

When determining the Frame Width, allow a minimum of 1/4" and maximum of 1/2" for shimming and caulking at the Jambs, head, and sidelite sill for StormMax® storefronts. For StormMax® curtain wall installations, use recommended joint size for each given system and include a minimum 1/4" shim space at the door Header subframe to horizontal connection and a minimum 1/8" shim space at the Jamb subframe to vertical connection on both sides of entrance. A quick reference guide is below. For job specific installations, reference the shop drawings and approved site drawings.

For all installations, the door Jamb framing and curtain wall mullion and Subframe should continue to the slab. Review all measurement guides carefully as some include a spacing for a joint between the slab and the Sill or Subsill and this space should not be allowed at Door Jamb framing.

MSD-375/WSD-500 StormMax® Entrance Installation and Glazing Manual

1.1 MSD-375/WSD-500 StormMax® Entrance As Standalone

For standalone installations where the MSD-375/WSD-500 StormMax® entrance is to be installed directly against other substrate and not within a storefront or curtain wall elevation, the entrance installation is straight-forward. Measure the rough opening and use the smallest width and smallest height dimension to verify the entrance system will fit.

Doors are provided at standard single or standard pair sizes, though the Door Jamb members may be provided long in the event a transom is required. For entrances with transoms, use the smallest rough opening height dimension to fabricate the Door Jamb members. For a visual aid, reference Figure 3 and Figure 4.

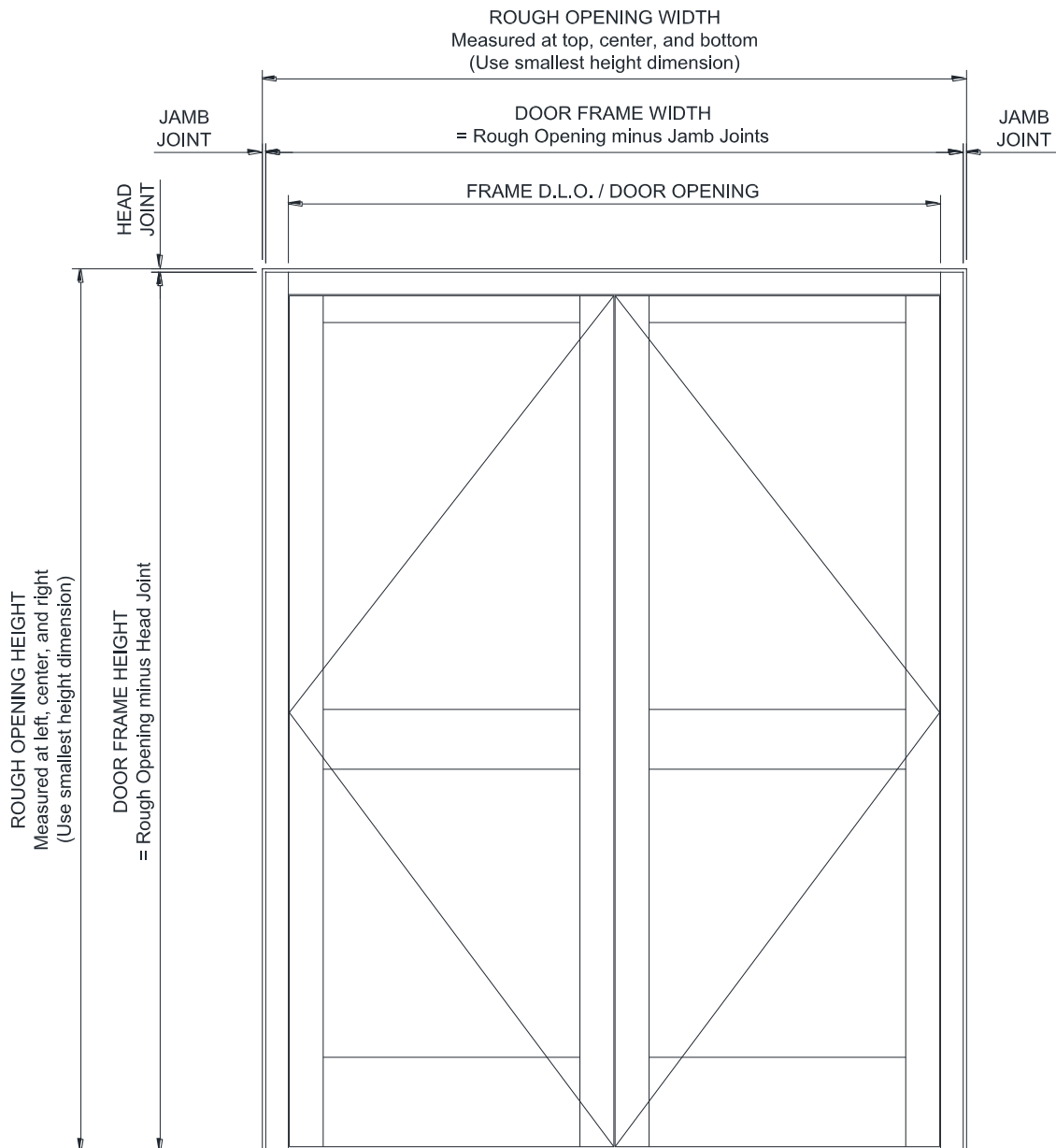

Figure 3: MSD-375/WSD-500 StormMax® Entrance as Standalone without Transom

MSD-375/WSD-500 StormMax® Entrance Installation and Glazing Manual

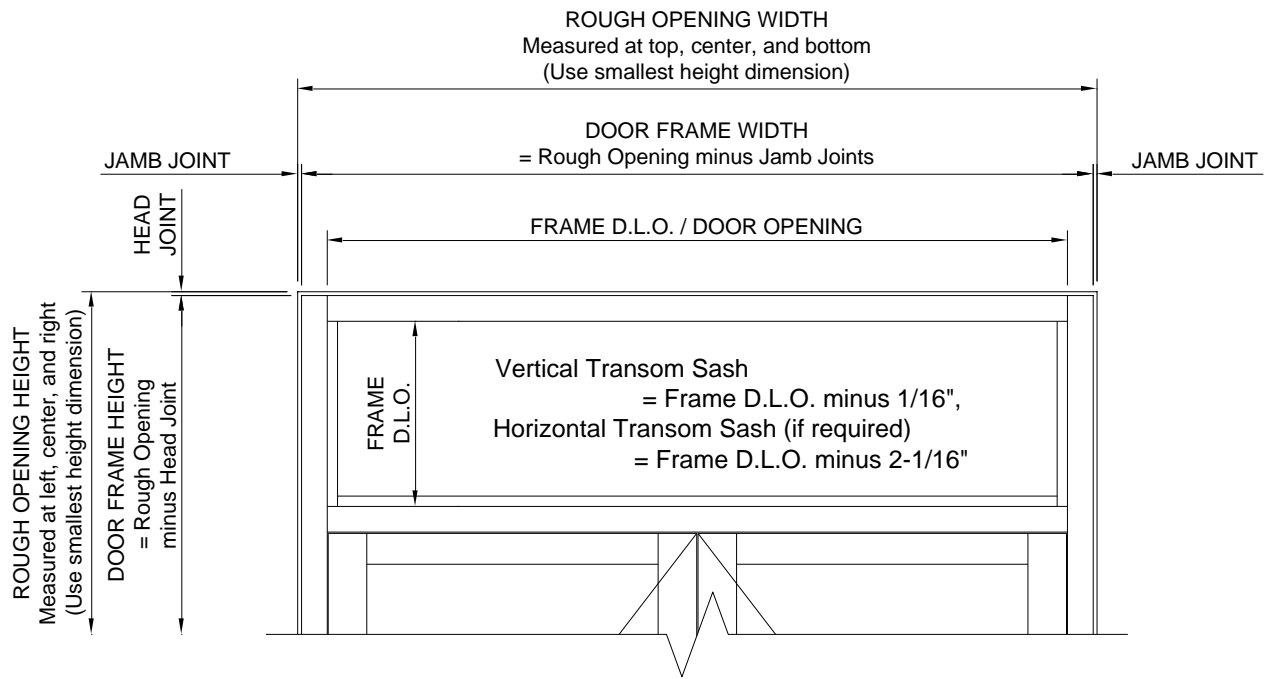

Figure 4: MSD-375/WSD-500 StormMax® Entrance as Standalone with Transom

MSD-375/WSD-500 StormMax® Entrance Installation and Glazing Manual

1.2 MSD-375/WSD-500 StormMax® Entrance in StormMax® Storefronts

For installations where the MSD-375/WSD-500 StormMax® entrance is to be installed alongside an FG-5700/FG-5750/FG-5750T StormMax® storefront, the rough opening will determine overall storefront frame size and the Door Jamb will be sized and fabricated to the Vertical at Door measurement. Typically, the Door Jamb extends past Subsill to the slab or lower substrate. Verify the measurement with the associated storefront installation manual. For a typical visual, reference *Figure 5* below.

Note: Subsill Height varies:

Subsill	Subsill Height
FG-5180	1/8"
FG-5712 / FGT-5712	5/8"
FGT-5726 / FGT-5726	5/8"

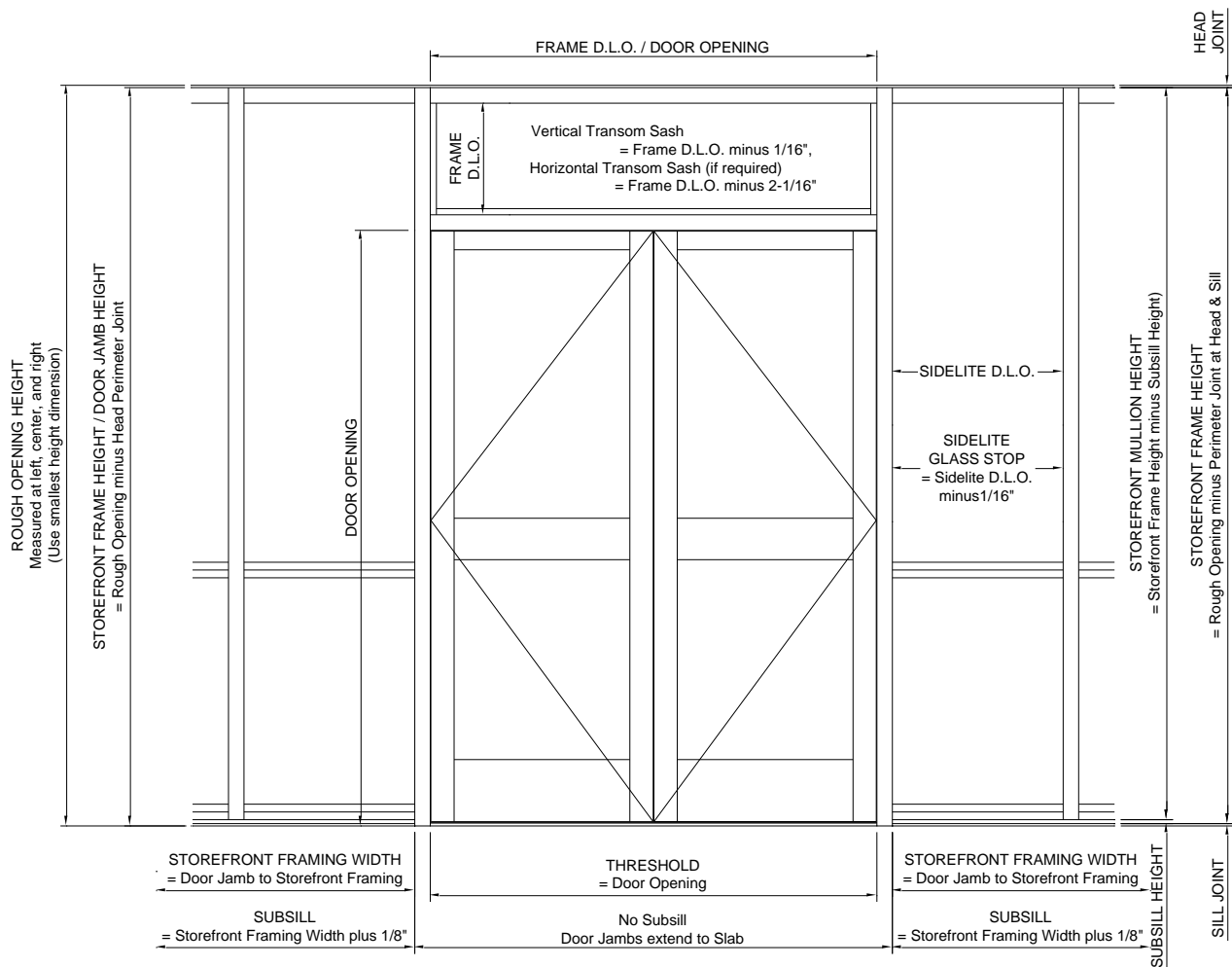

Figure 5: MSD-375/WSD-500 StormMax® Entrance in FG-5700/FG-5750/FG-5750T StormMax® Storefront

MSD-375/WSD-500 StormMax® Entrance Installation and Glazing Manual

1.3 MSD-375/WSD-500 StormMax® Entrance in Curtain Walls

The MSD-375/WSD-500 StormMax® Entrance can be installed in Oldcastle BuildingEnvelope®'s hurricane-resistant curtain wall solutions. The procedure requires a low profile Subframe within the curtain wall opening to receive the door and associated hardware. A 1/4" shim space is recommended at the attachment of Header Subframe to Horizontal to allow Subframe to clear Threshold anchor plate, while Jambs require a 1/8" shim space. Overall Frame Height will be determined by the curtain wall system's standard joint widths, though the Subframe Jambs and the abutting curtain wall Verticals will extend to the slab without a Sill joint. See *Figure 6* for visual reference.

Note: Subframe Header Height varies:

Closer Type	Subframe Header Height
Surface Closer	1"
Concealed Closer	2 1/2"

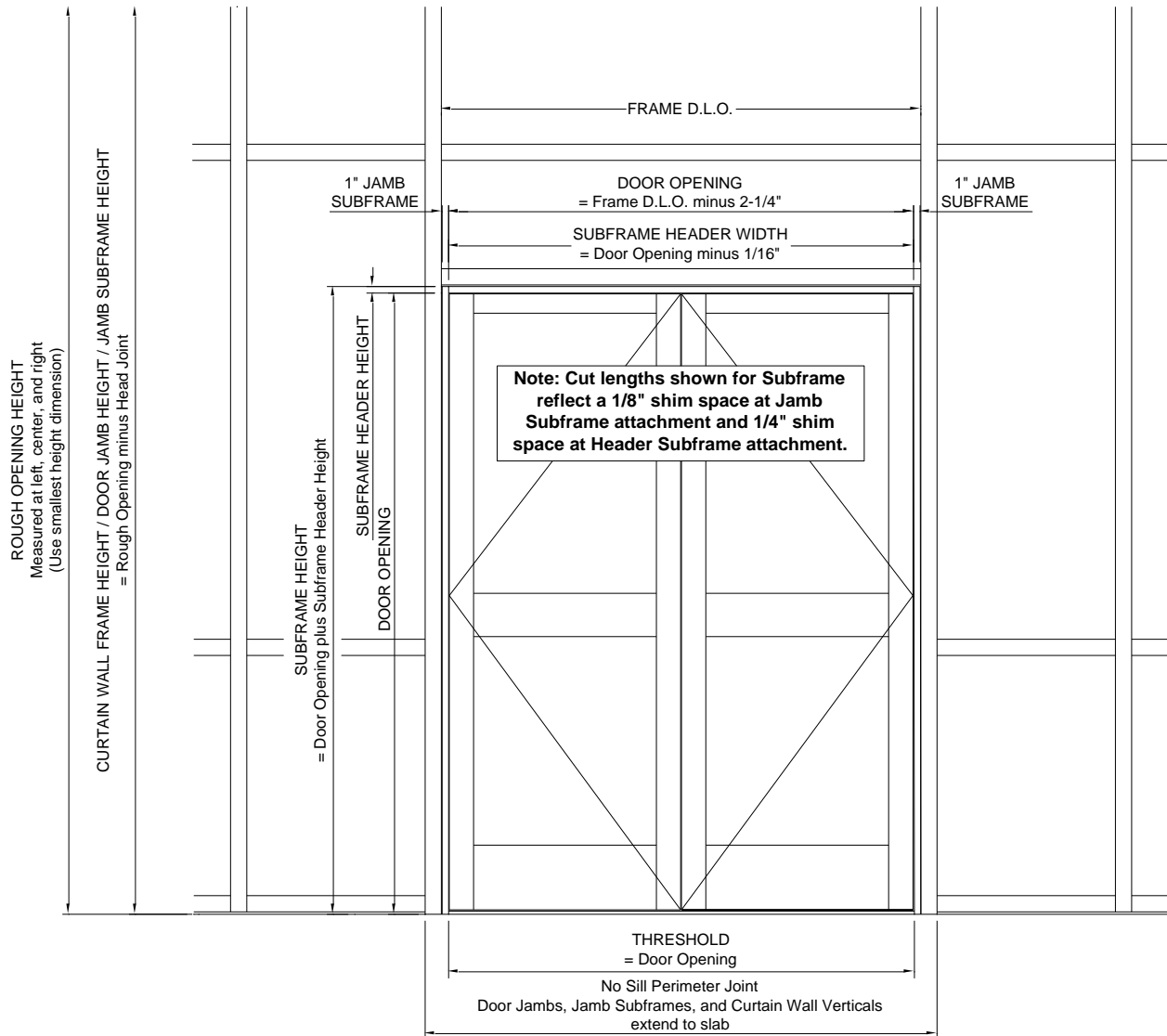

Figure 6: MSD-375/WSD-500 StormMax® Entrance in StormMax® Curtain Walls

MSD-375/WSD-500 StormMax® Entrance Installation and Glazing Manual

1.4 Door Stop Lengths

The MSD-375/WSD-500 StormMax® Entrance Door Stops vary by installation instance. Use the following guide to ensure the material is cut to the appropriate length for the installation.

FG-5163

- At Surface Closer:
 - Vertical Stops:
Door Opening minus 9/16"
 - Horizontal Stops:
 - Offset Pivot and Butt Hinge Door:
Door Opening minus 1-1/16"
 - Gear Hinge Door:
Door Opening minus 1-5/16"
- At Concealed Closer:
This Stop only used vertically with Concealed Closer.
 - Vertical Stops:
Door Opening minus 1-5/8"

FG-5222 / FG-5223

- Surface Closer:
 - Vertical Stops:
Door Opening minus 9/16"
- Concealed Closer:
This Stop is only used vertically with Concealed Closer.
 - Vertical Stops:
Door Opening minus 1-5/8"

DS-104

- Concealed Closer:
This Stop is only used horizontally with Concealed Closer.
 - Horizontal Stops:
Door Opening minus 1/16"

MSD-375/WSD-500 StormMax® Entrance Installation and Glazing Manual

2.0 Preparation of Door Frame for Installation

2.1 Preparation of Door Frame with FG-5700 StormMax® Framing

- All hardware backup plates are installed in the frame at the factory.
 - Door Stops and Transom Sash are cut to length and prepped at the factory.
- 2.1.1 Review the frame anchor charts in the product approvals or approved shop drawings for configuration and substrate for which the frame will be attached. Drill anchor holes into **FG-5713** Door Jamb and **FG-5715** Flat Filler per StormMax® storefront manual. If anchor holes in Threshold are factory drilled, verify layout, quantity, and spacing per structural review. When installing FG-5700 without transom and using a **FG-5766** Header it will require installing a **FG-5716** filler for anchor support.
- 2.1.2 Stock transom frames are fabricated for a vertical frame size of 120". If the intended opening is smaller, cut the verticals and sash down to the appropriate length; leave a minimum 1/4" and a maximum of 1/2" caulk joint at the Head. Reference *Figure 5*.
- 2.1.3 Prep Door Jamb for the Door Header and/or Transom Head horizontal. This should be made using either **DJ-5700** drill fixture or EZ-Punch die set. Reference *Figure 7* for visual prep detail.
- 2.1.4 For Butt Hinge or Offset Pivot assembly, the frame will be factory prepped with back-up plates. For Continuous Gear Hinge, the Door Jamb will be sent "blank". Installation guide provided in *Section 17.0 Hanging Gear Hinge Door*.

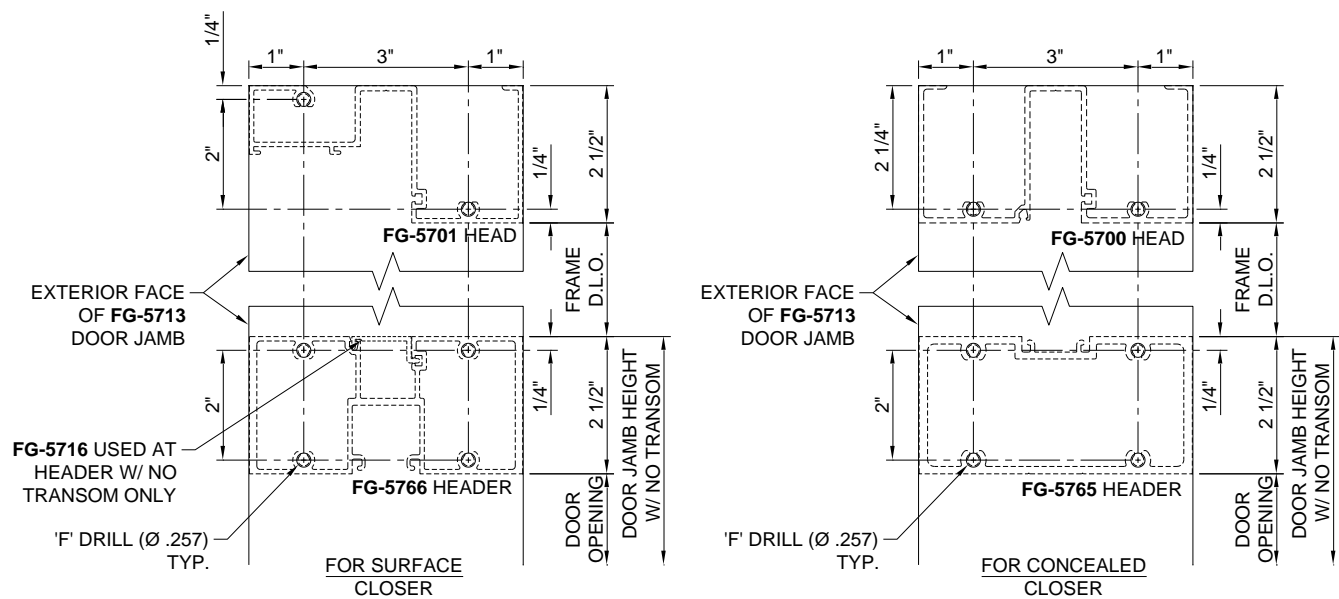

Figure 7: Fabrication for FG-5700 StormMax® Framing at Transom Head and Door Header

MSD-375/WSD-500 StormMax® Entrance Installation and Glazing Manual

2.2 Preparation of Door Frame with FG-5750 or FG-5750T StormMax® Framing

NOTES:

- All hardware backup plates are installed in the frame at the factory.
- Door Stops and Transom Sash are cut to length and prepped at the factory.

- 2.2.1 Review the frame anchor charts in the approved shop drawings for configuration and substrate for which the frame will be attached. Drill anchor holes into **FG-5713** Door Jamb and **FG-5715/FG-5719** Flat Filler per FG-5750 or FG-5750T StormMax® storefront manual.
- 2.2.2 If anchor holes in Threshold are factory drilled, verify layout, quantity, and spacing per structural review.
- 2.2.3 Stock transom frames are fabricated for a vertical frame size of 120". If the intended opening is smaller, cut the verticals and the sash down to the appropriate length; leave a minimum 1/4" and a maximum of 1/2" caulk joint at the Head. Reference Figure 5.
- 2.2.4 Prep Door Jamb for the Door Header and/or Transom Head Horizontal. This should be made using either **DJ-5700** or **DJ-5750** drill fixture or EZ-Punch die set. Reference *Figure 8* for visual detail. For entrances with Surface Closer and without Transom, **FG-5766** Door Header should be used. Reference Figure 7 for prep.
- 2.2.5 For Butt Hinge or Offset Pivot assembly, the frame will be factory prepped with back-up plates. For Continuous Gear Hinge, the Door Jamb will be sent "blank". Installation guide provided in *Section 17.0 Hanging Gear Hinge Door*.

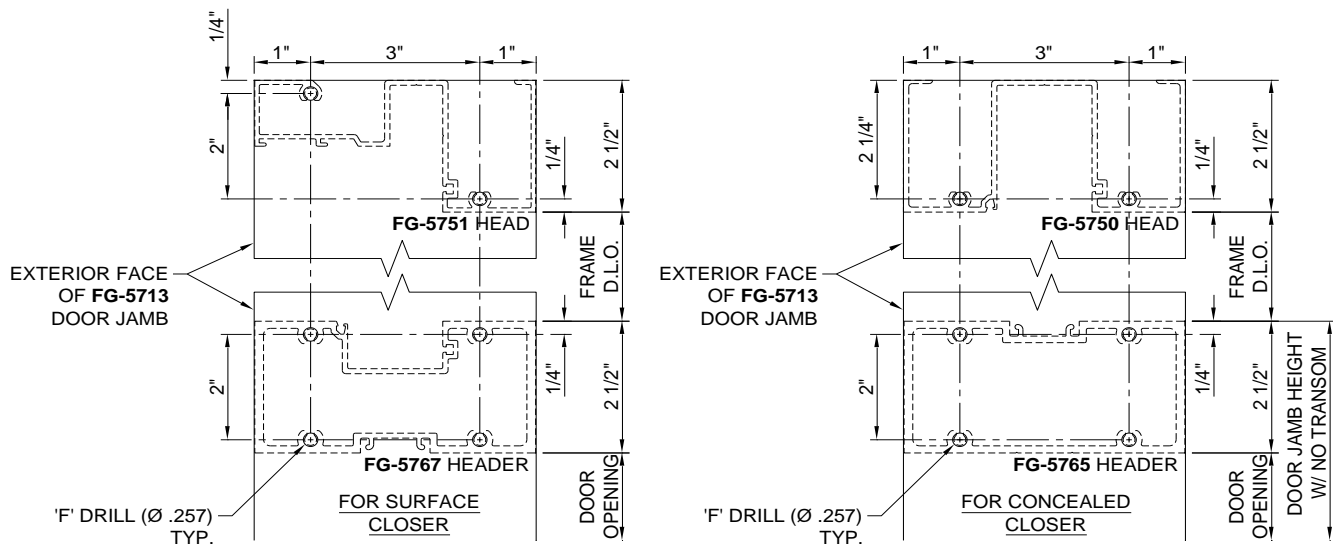

Figure 8: Fabrication for FG-5750 StormMax® Framing at Transom Head and Door Head

MSD-375/WSD-500 StormMax® Entrance Installation and Glazing Manual

2.3 Preparation of Curtain Wall Header Subframes

Note: Prep for Header Subframe is unique.

2.3.1 Fabricate per Figure 9.

2.3.2 Concealed Overhead Closers will use the **FG-5765** Subframe while Overhead Surface Closers will use **D-231**.

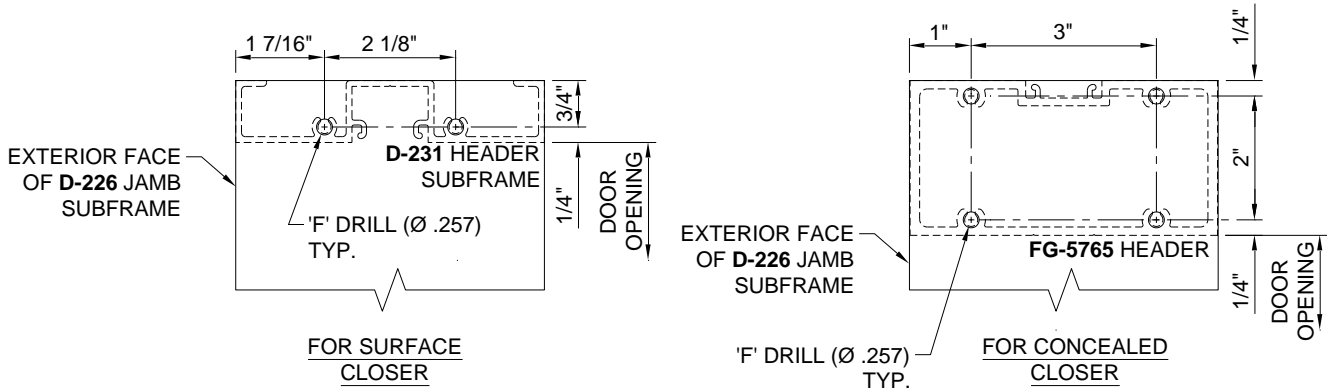

Figure 9: Fabrication for Curtain Wall Subframe at Headers

2.4 Preparation of Storefront Frame or Curtain Wall Subframe for Threshold

2.4.1 Cut Threshold to Door Opening dimension

2.4.2 Fabricate Frame/Subframe per Figure 10.

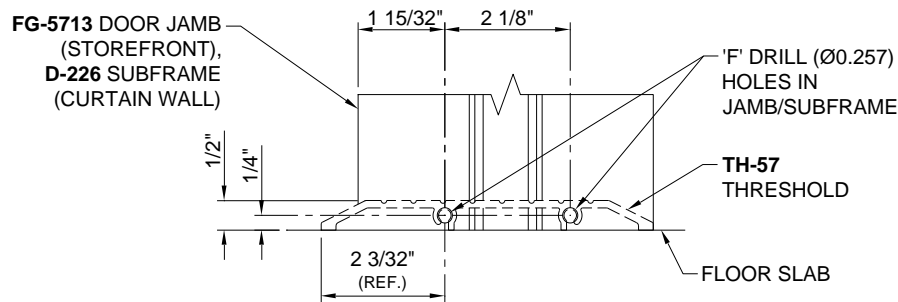

Figure 10: Fabrication for TH-57 Threshold

2.5 Reinforcement Fabrication and Attachment for FG-5713 Door Jamb

NOTES:

- **FG5000-PP-8** Steel Reinforcement must be used in Sidelite Door Jambs to satisfy structural requirements.
- If reinforcement is attached prior to assembling door frames, access holes will need to be fabricated in steel to enable installation of frame assembly fasteners.

2.5.1 Drill clear holes in Door Jamb as shown in Figure 11 using 'H' bit (Ø 0.266).

2.5.2 Center Reinforcement inside the Door Jamb and match drill attachment holes for 1/4"-20 fasteners. Holes in Reinforcement should be 3/4" from each end.

2.5.3 Attach Reinforcement to Door Jamb with **FS-354**.

MSD-375/WSD-500 StormMax® Entrance Installation and Glazing Manual

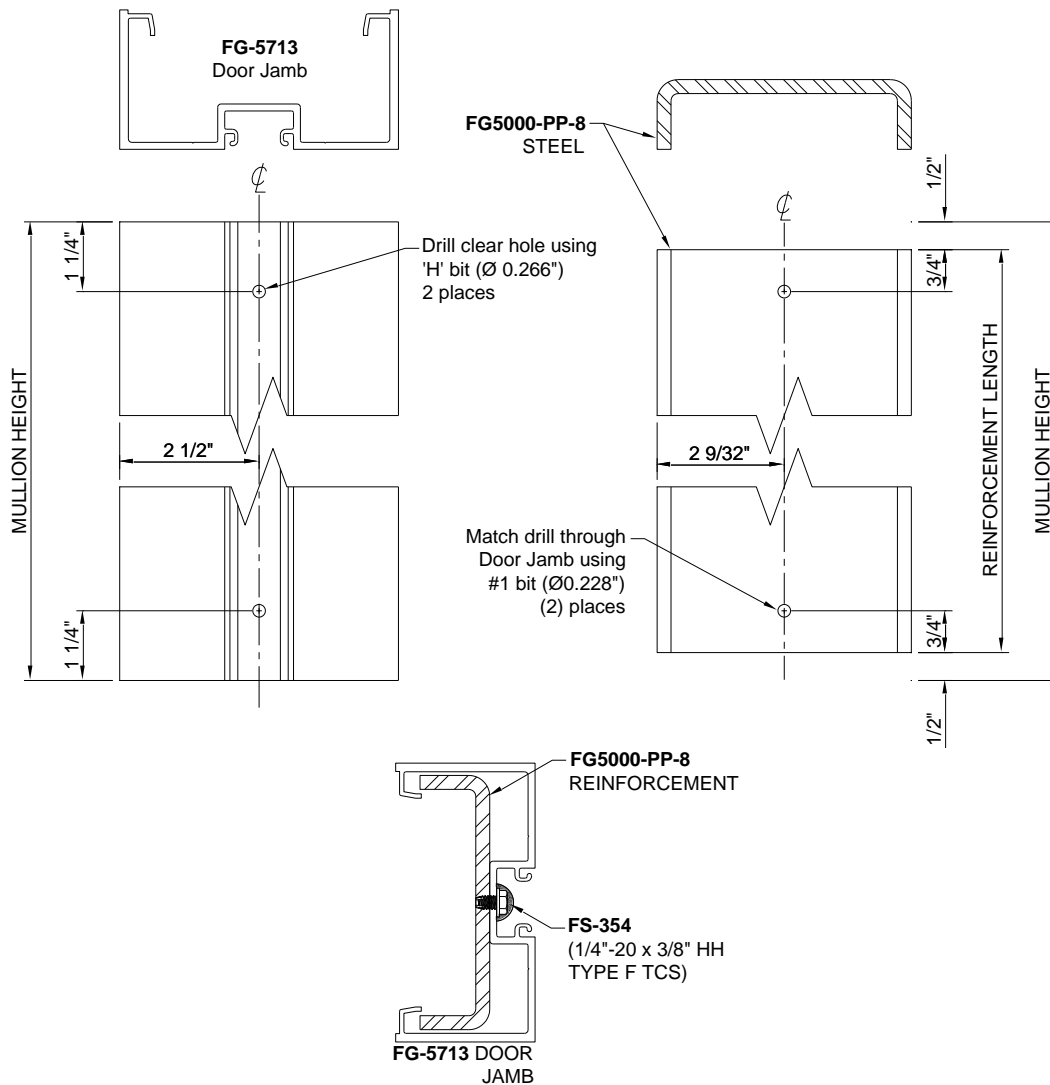

Figure 11: Hole Prep for Aluminum/Steel Reinforcement

FRAME ASSEMBLY

3.0 Assembling Door Frame with FG-5700 StormMax® Storefront

- 3.1 Reference Figure 12 and Figure 13 to attach Door Jamb to Door Header and Transom Head (if applicable).
- 3.2 Just prior to assembly, apply silicone weather sealant to Door Jamb and butter end of Door Header and Transom Head (if applicable) as shown below.
- 3.3 Assemble with **FS-8** fasteners.

MSD-375/WSD-500 StormMax® Entrance Installation and Glazing Manual

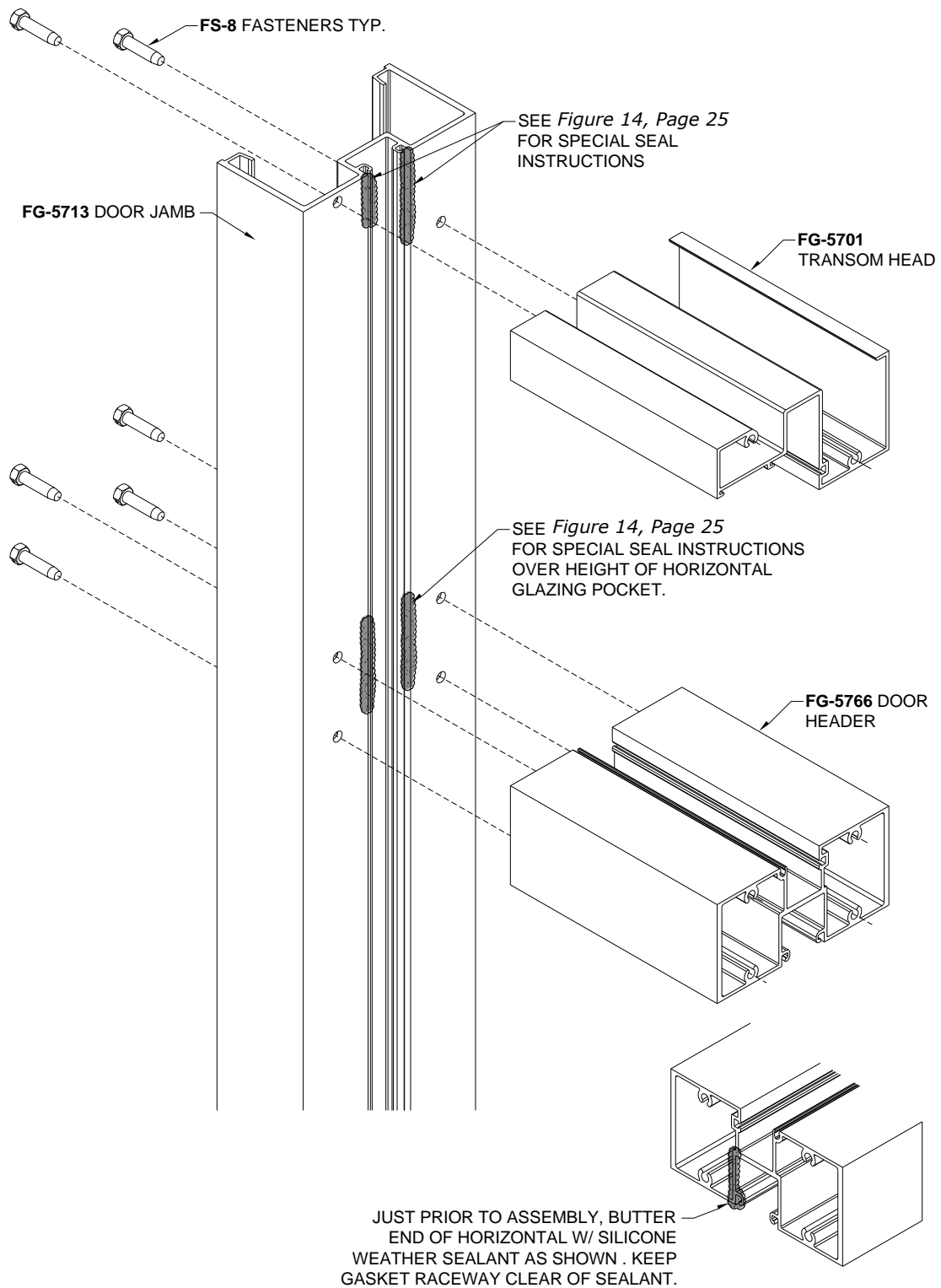

Figure 12: FG-5700 StormMax® Door Frame Assembly Option 1

MSD-375/WSD-500 StormMax® Entrance Installation and Glazing Manual

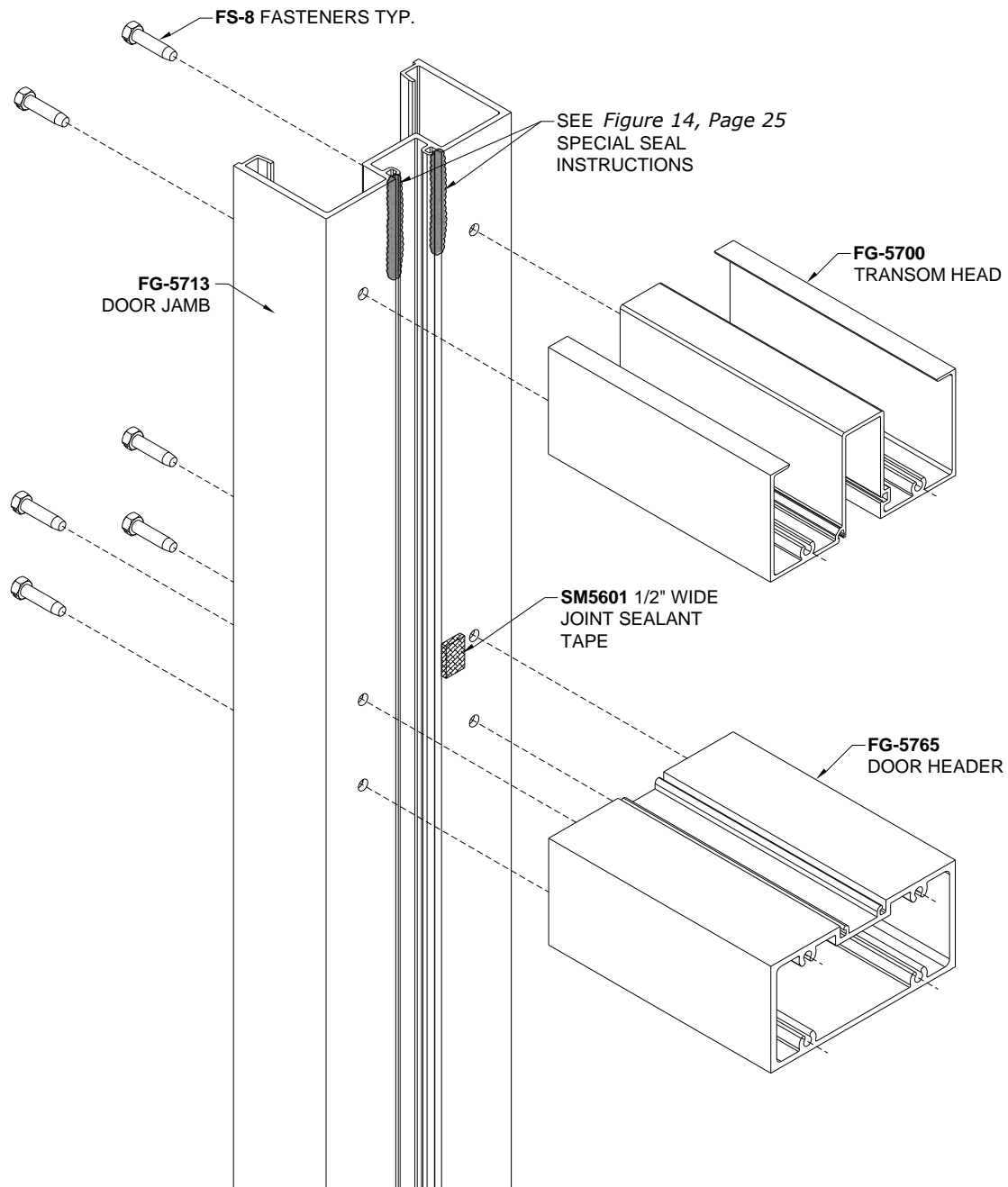

Figure 13: FG-5700 StormMax® Door Frame Assembly Option 2

- 3.4 When **FG-5713** Door Jamb is used with **FG-5700**, **FG-5701** and/or **FG-5766** Horizontals, the joinery at the door pocket of **FG-5713** to the Horizontal glazing pockets requires a special seal to be performed after frame is assembled but before installation. Reference Figure 14 to add a seal along vertical reglets of **FG-5713** at joinery. Tool so a continuous seal is made to the walls of the horizontal glazing pocket, terminating at horizontal D.L.O.'s.

MSD-375/WSD-500 StormMax® Entrance Installation and Glazing Manual

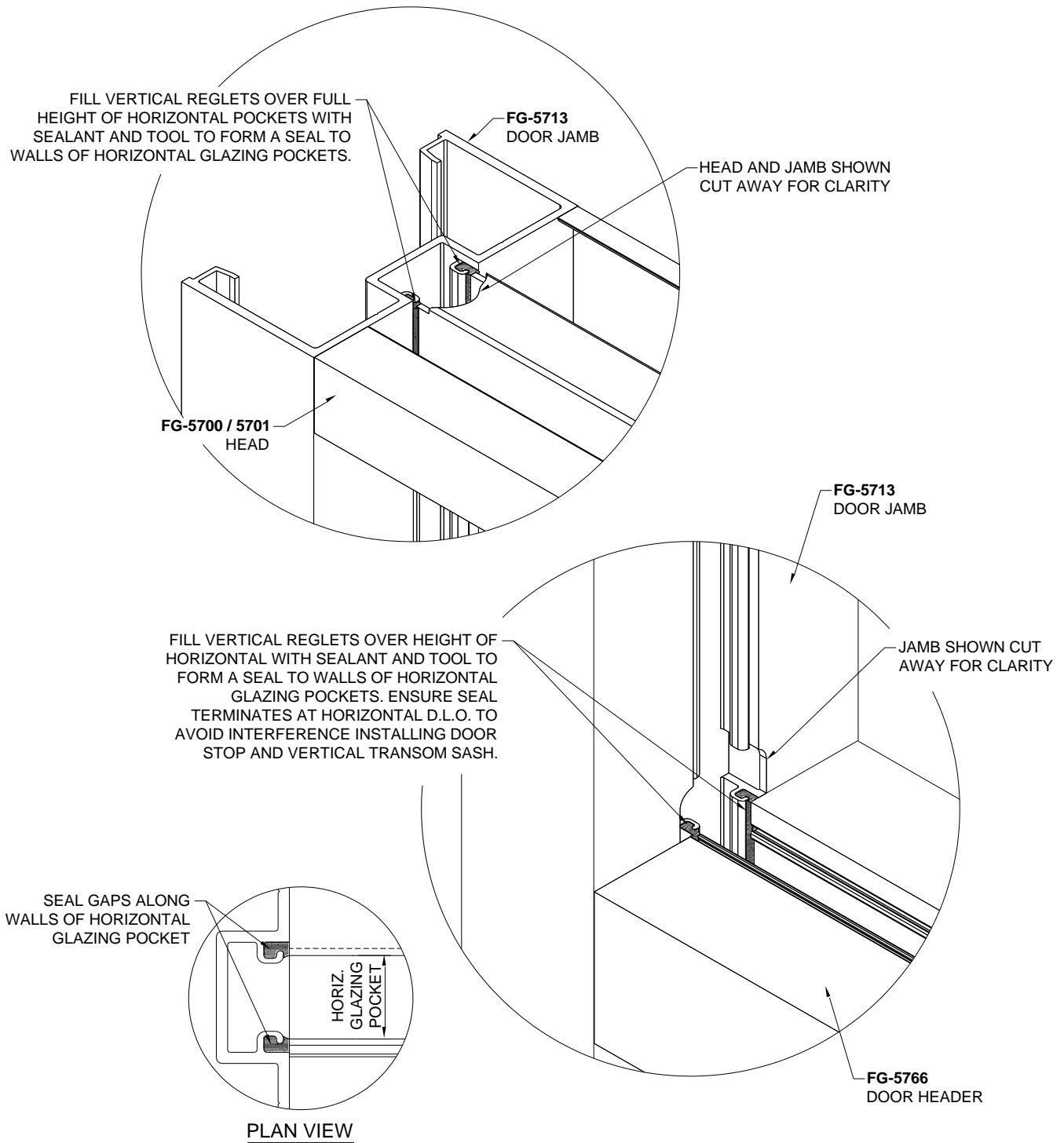

Figure 14: Special Seal at FG-5700, FG-5701, and FG-5766 Joinery with Door Jamb

MSD-375/WSD-500 StormMax® Entrance Installation and Glazing Manual

4.0 Assembling Door Frame with FG-5750 or FG-5750T StormMax® Storefront Framing

- 4.1 Reference Figure 15 and Figure 16 to assemble Door Jamb to Door Header and Transom Head (if applicable).
- 4.2 Apply **SM5601** 1/2" Joint Sealant Tape at joinery of Door Jamb and Horizontal members.
Note: Keep screw splines clear of tape.
- 4.3 Assemble with **FS-8** fasteners.

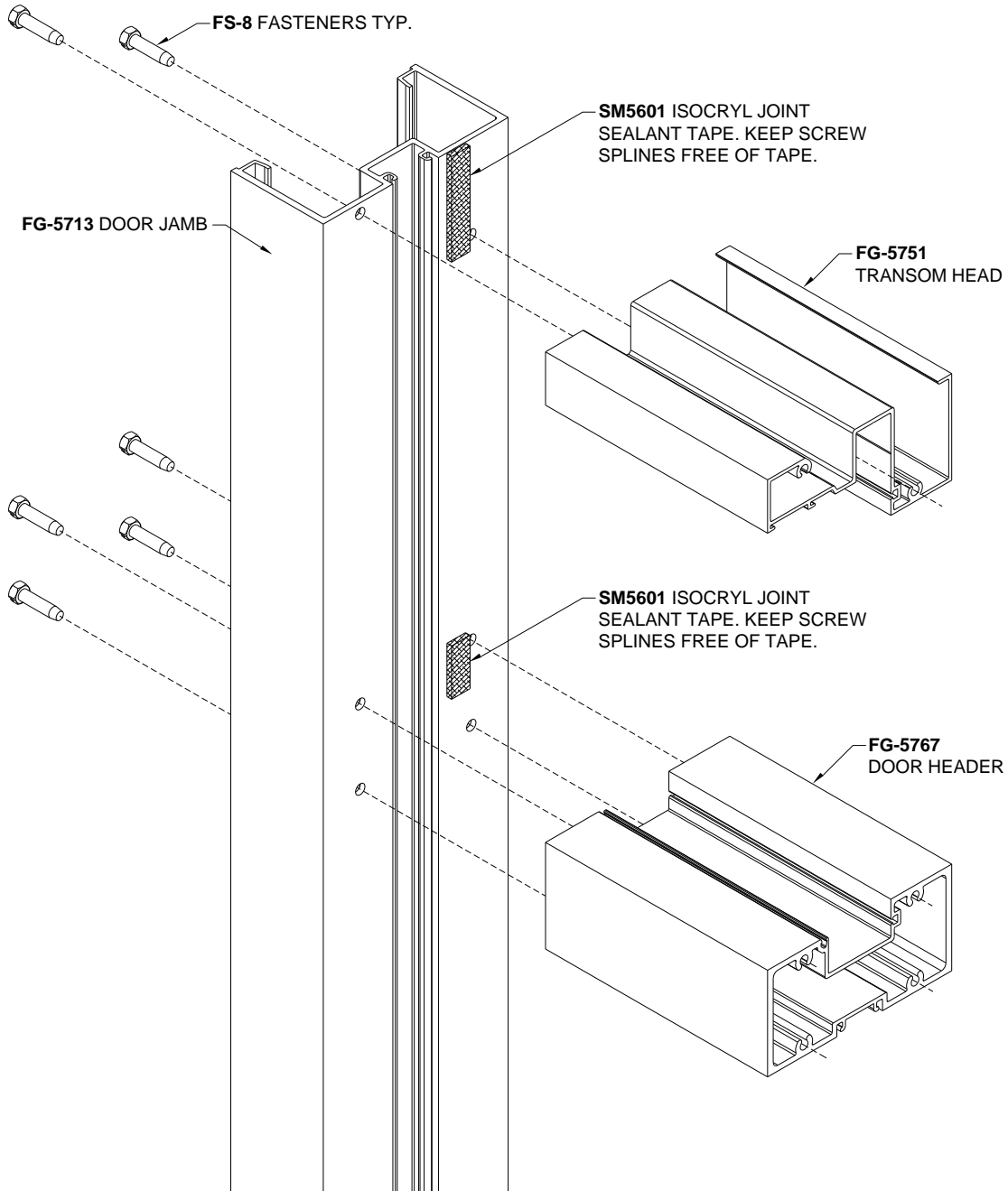

Figure 15: FG-5750 StormMax® Door Frame Assembly Option 1

MSD-375/WSD-500 StormMax® Entrance Installation and Glazing Manual

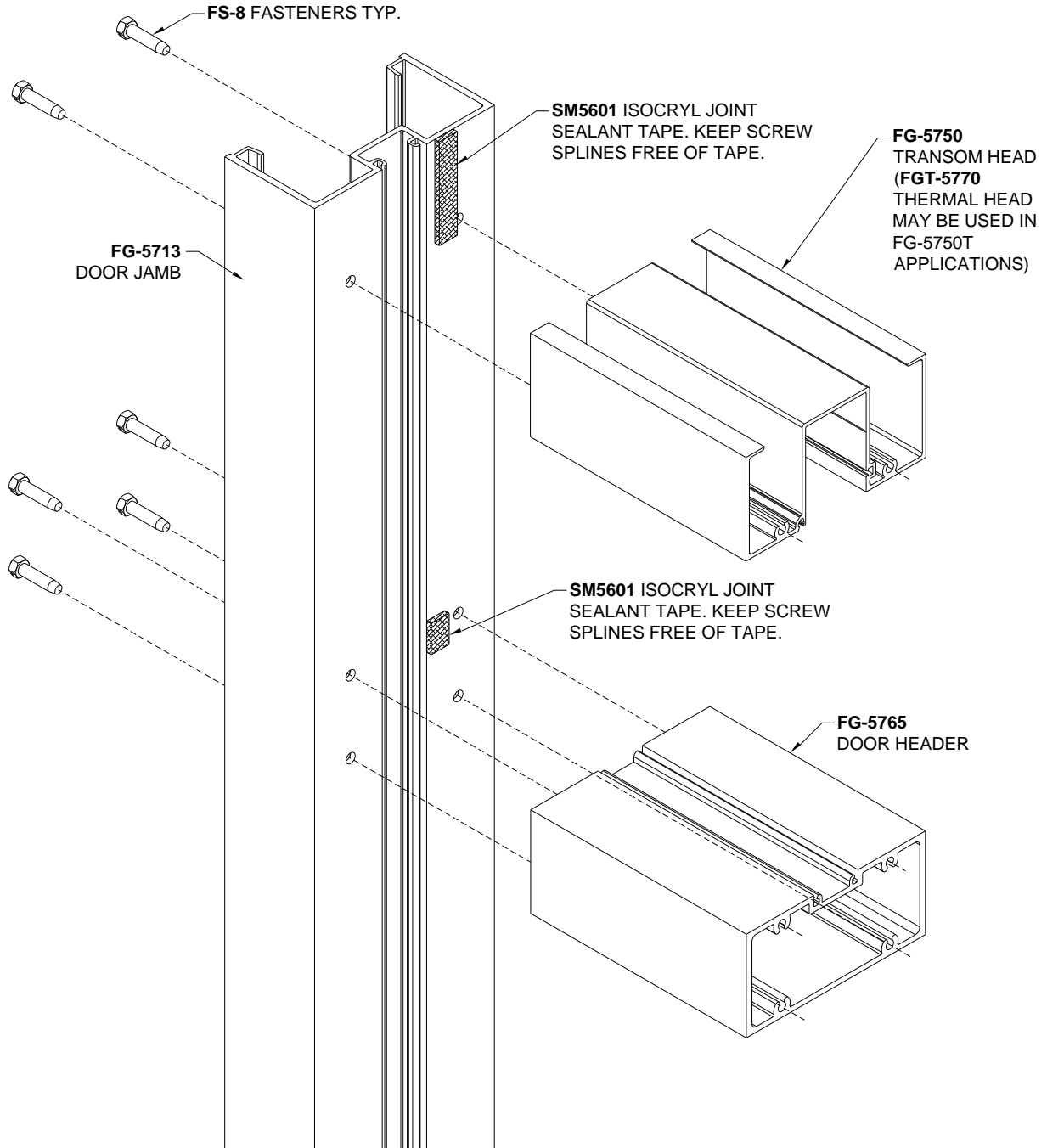

Figure 16: FG-5750 StormMax® Door Frame Assembly Option 2

MSD-375/WSD-500 StormMax® Entrance Installation and Glazing Manual

5.0 Assembling Door Subframes for StormMax® Curtain Walls

- 5.1 Reference Figure 17 and Figure 18 to attach Door Jamb Subframe to Door Header Subframe using **FS-8** fasteners.
- 5.2 Seal interior joinery as shown.
Note: See Section 9.5 for information pertaining to shim space.

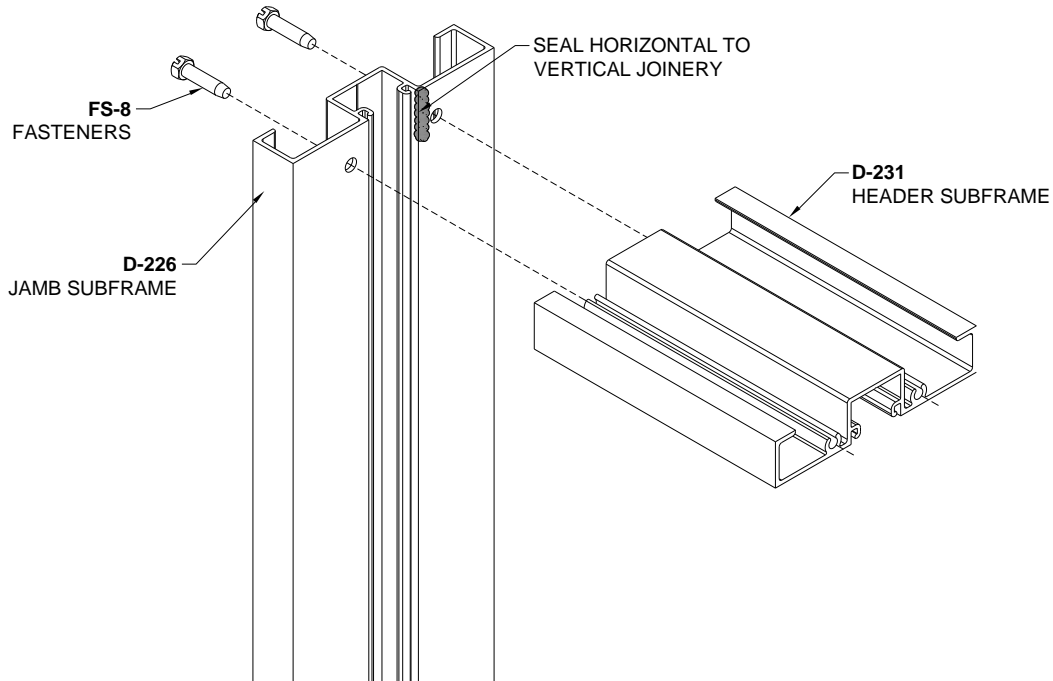

Figure 17: Curtain Wall Subframe Assembly at Header for Surface Closer

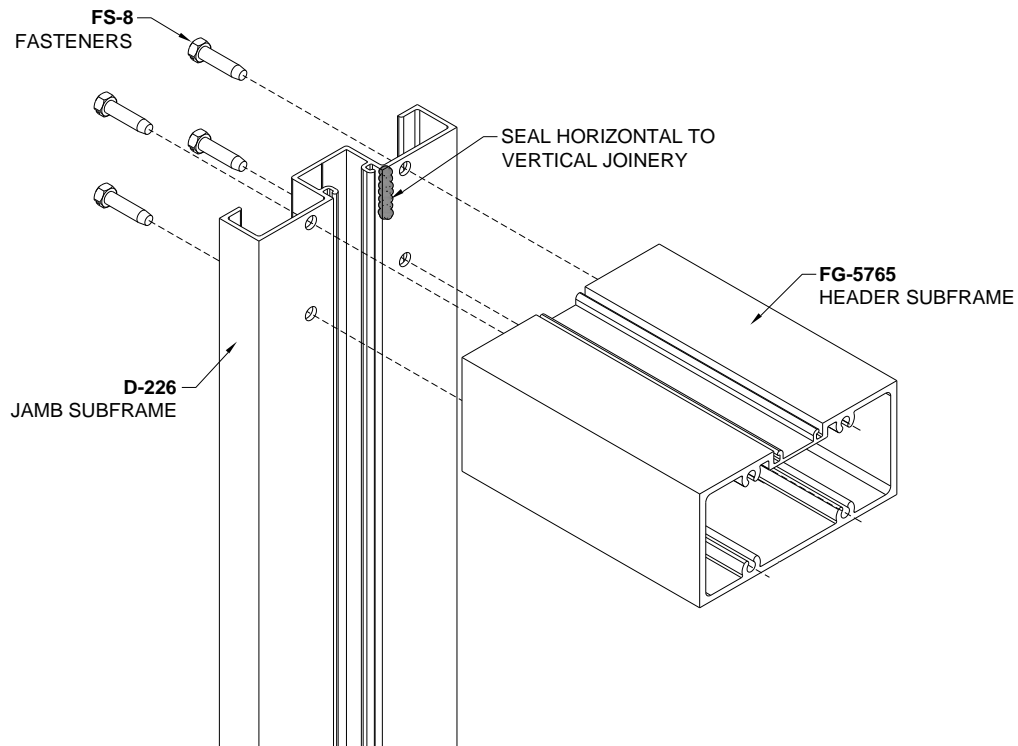

Figure 18: Curtain Wall Subframe Assembly at Header for Concealed Closer

MSD-375/WSD-500 StormMax® Entrance Installation and Glazing Manual

6.0 Attaching Threshold to Frames/Subframes

Note: Threshold assembly is identical for storefront frames and curtain wall Subframes.

- 6.1 Apply **SM5601** Joint Sealant Tape to Door Jamb as shown below, notching Sealant Tape at fastener locations to prevent tape from interfering with Threshold screw splines.
- 6.2 Attach **TH-57** Threshold to Jambs with **FS-8** assembly fasteners, as shown in Figure 19.
*Note: **Threshold is a handed part**; ensure longer leg is to the exterior.*
- 6.3 Trim excess tape around contour of Threshold. Use a bladed tool; do not pull to trim.
- 6.4 Reference Figure 20 for fabrication and installation for **D134-3** Panic Stop.

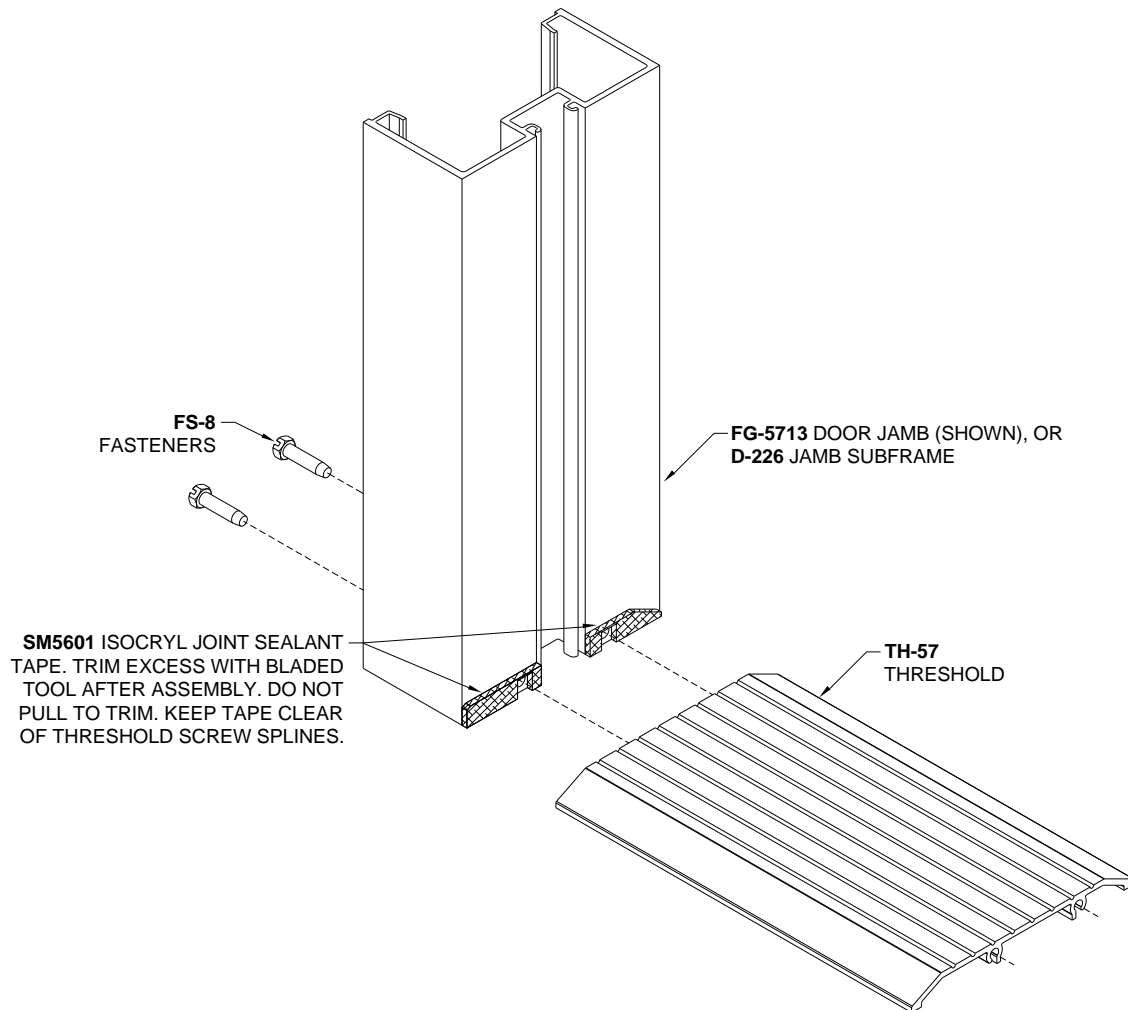

Figure 19: Threshold Attachment

MSD-375/WSD-500 StormMax® Entrance Installation and Glazing Manual

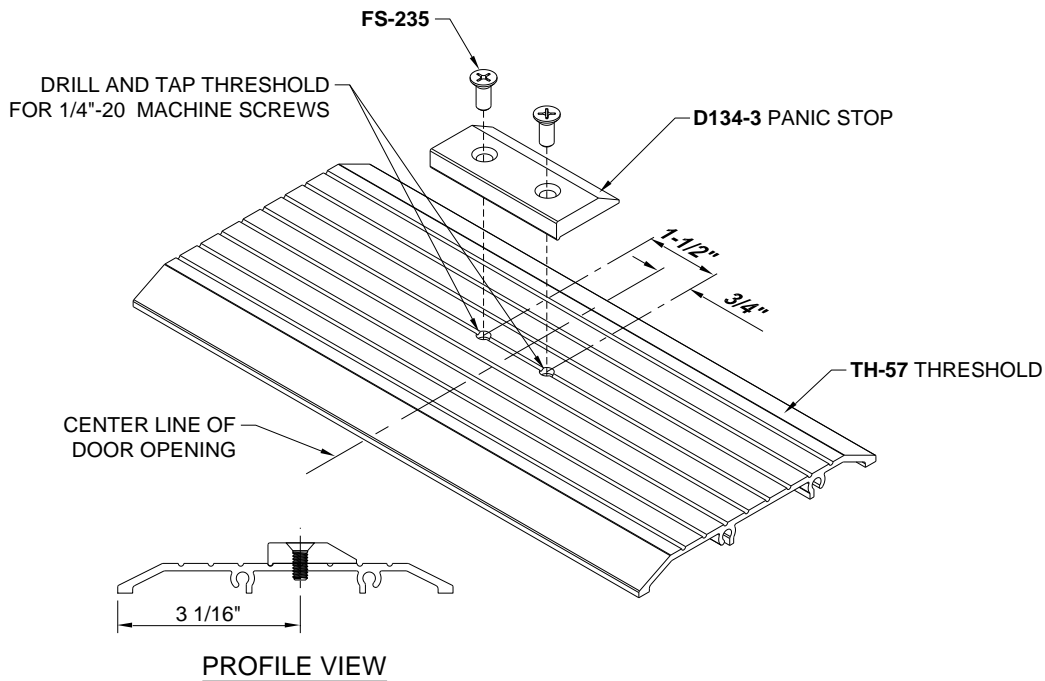

Figure 20: Panic Stop Attachment

FRAME INSTALLATION

NOTES:

- Thresholds are to be leveled at the high point in the slab. However, it is preferable to not have a high point in the slab where entrances occur. The door frame is designed to have the Jambs run to the slab.
- Storefront door frames are anchored by fasteners at Jambs, Threshold and door frame Header or Transom Head, if applicable. Refer to Anchor Charts in Product Approval or approved shop drawings for anchor size, quantity and layout.

7.0 Installing Door Frame at FG-5700/FG-5750 StormMax® without Sidelite

Door Frame and Threshold shall be completely assembled with joints neatly aligned and tight. Door Frame shall be installed square and plumb.

- 7.1 Measure frame diagonally from corner to corner on both sides to check frame squareness. Adjust as needed until frame is square.
- 7.2 The Threshold Anchor Plate may be used in pieces at anchor bolts locations only (as **FG5000-FP-19**), or it may be used continuously (as extrusion **TH-60**). The Plate, whether continuous or in pieces, does not attach to the floor substrate. The Anchor Plate is used to ensure anchor bolts do not bend under load. Plate(s) should be drilled for a clear hole at each anchor bolt location. The Plate(s) may be either pre-located on the floor substrate or taped in place or secured via silicone sealant to underside of Threshold to facilitate installation. If pre-located on floor substrate, the centerline of the Plate will be set back 2-17/32" from leading edge of Jamb. Reference Figure 22. Anchor bolt size, quantities, and layout to be determined via structural review. Refer to approved shop drawings.
- 7.3 Run line of silicone weather sealant 6" up interior snap engagement of Jambs starting from bottom. Reference Figure 21 for seal.
- 7.4 Snap **FG-5715** Flat Fillers into Jambs. As an option, the **FG-5719** vinyl Flat Filler may be used for improved thermal performance. Flat Fillers shall be prepped with clear holes at anchor bolt

MSD-375/WSD-500 StormMax® Entrance Installation and Glazing Manual

- locations to allow for anchoring of Jamb directly into substrate. **Do not anchor Jamb by attaching Flat Filler directly to substrate.**
- 7.5 Create dual beds of sealant on substrate along both the interior and exterior edges of Threshold location. Also, fill voids on the underside of Threshold front & rear with weather sealant. Do not allow sealant to skin over before proceeding to next step.
 - 7.6 Create bed of sealant where Jamb will contact substrate and butter bottom ends of Jambs with sealant. **Important: Leave front of Jamb free of sealant.** Do not allow sealant to skin over before installation.
 - 7.7 Install assembled frame. Reference Figure 22.
 - 7.8 Anchor Threshold through Anchor Plate(s) and into slab with flat head anchor bolts per anchor charts or approved shop drawings.
 - 7.9 Wipe away excess sealant from Threshold and Jamb locations immediately after installing. Exposed front ends of Threshold must be sealed after frame installation to prevent water encroachment under the Threshold and into the building or substrate. Reference Figure 23 for pictorial representation of this seal.
 - 7.10 Shim and anchor Jambs and Header per anchor charts or approved shop drawings.
 - 7.11 For installation of Door Stops, reference guide in *10.0 Installing Door Stops*.
 - 7.12 For entrances with Transoms, install Transom Sashes per *11.0 Installing Transom Sash*.

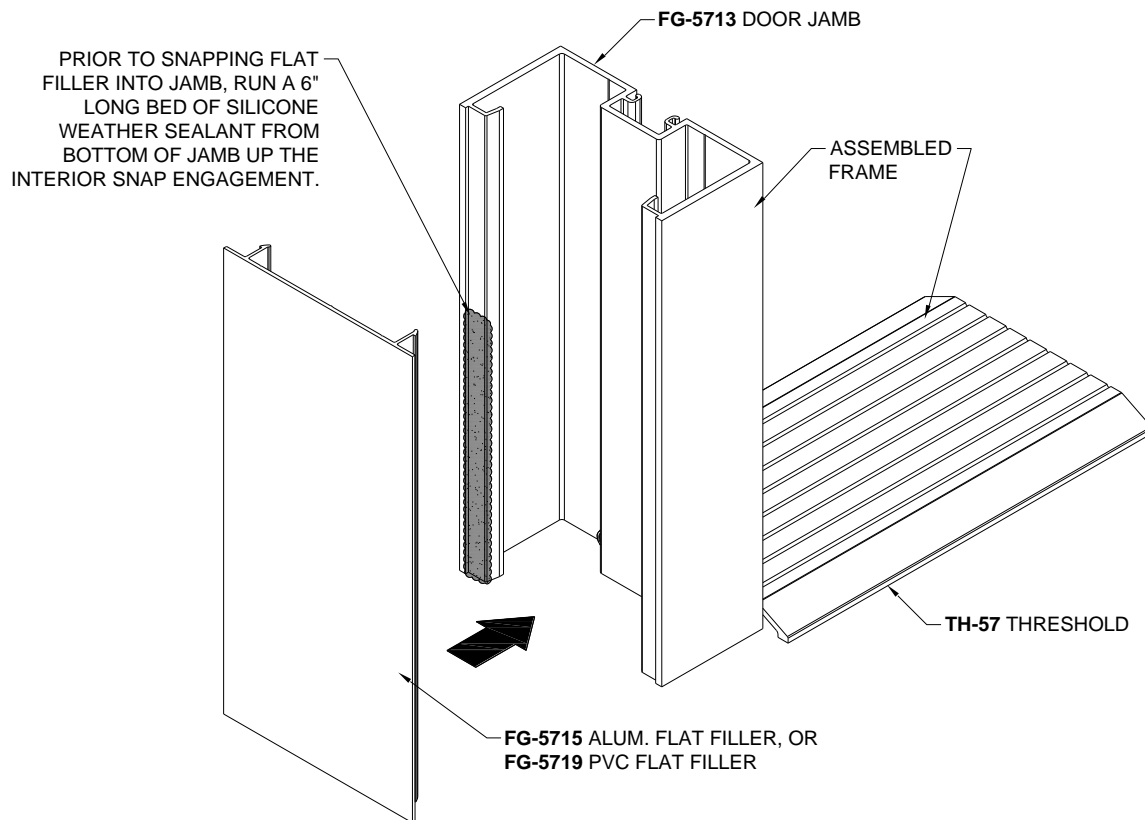

Figure 21: Flat Filler Installation

MSD-375/WSD-500 StormMax® Entrance Installation and Glazing Manual

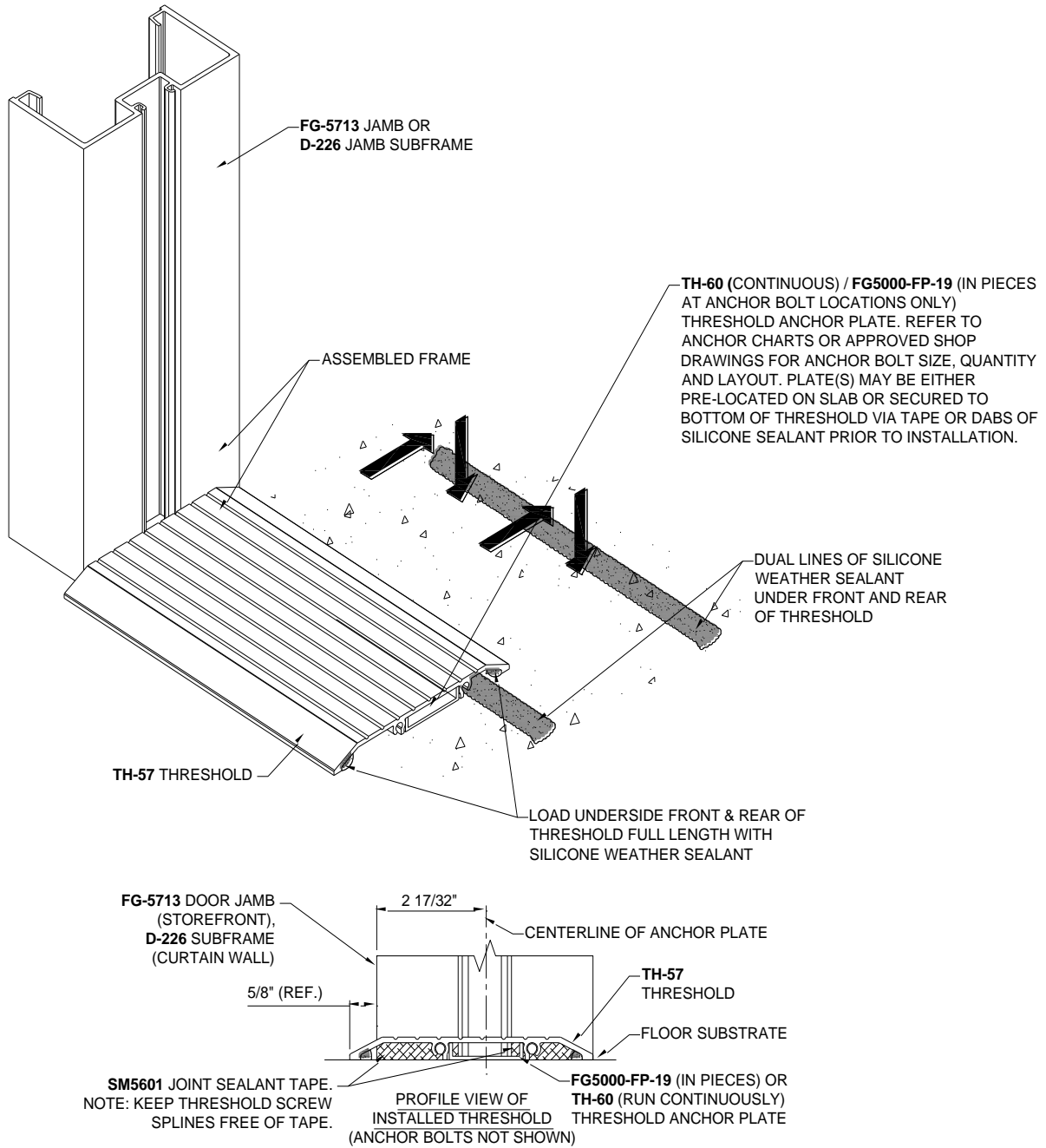

Figure 22: Frame Installation

MSD-375/WSD-500 StormMax® Entrance Installation and Glazing Manual

8.0 Installing Door Frame in FG-5700/FG-5750/FG-5750T StormMax® with Sidelite

NOTES:

- Door Frame must be installed prior to Subsill and Sidelite.
- Sidelite Door Jambs must use **FG5000-PP-8** Steel Reinforcement.

- 8.1 Attach Steel Reinforcement per procedure outlined in *Step 2.5* on *Page 21*.
- 8.2 Install Door Frame first per the instructions in *Section 7.0*, leaving out the installation of the Flat Filler described in *Step 7.3* and the Jamb anchoring step in *Step 7.9*.
- 8.3 Seal the inside of the Door Jamb to the substrate per *Figure 23*, leaving the front face unsealed for drainage. Door Jambs run to the slab.
- 8.4 Apply a minimum of 6" long bed of sealant to the interior snap engagement of the Door Jamb, starting from bottom of jamb.
- 8.5 Install Sidelite Filler into Jamb. For reference, FG-5700 StormMax® uses **FG-5711**, while FG-5750 and FG-5750T StormMax® use **FG-5761**.
- 8.6 If using the **FG-5712, FGT-5712, FG-5726 or FGT-5726** Subsill, fill cavities at end with backer rod and seal over end of Subsill completely. For fill reference, see *Figure 23*. If using the **FG-5180** Subsill, butter end of extrusion generously with sealant. Do not allow sealant to skin over before proceeding to the next step.
- 8.7 Apply sealant to the Door Jamb and Sidelite Filler where the Subsill will make contact. *NOTE: Do not install End Dam on Subsill at Door Jamb.*
- 8.8 Shim and set the Sidelite Subsill in a bed of sealant and butt tight to Door Jamb. Tool sealant at joinery to form a tight seal.
- 8.9 Anchor Subsill per anchor charts in product approval or per approved shop drawings and cap seal anchor bolts.
- 8.10 Perform related seals and continue storefront installation per procedure described in respective storefront manual.

MSD-375/WSD-500 StormMax® Entrance Installation and Glazing Manual

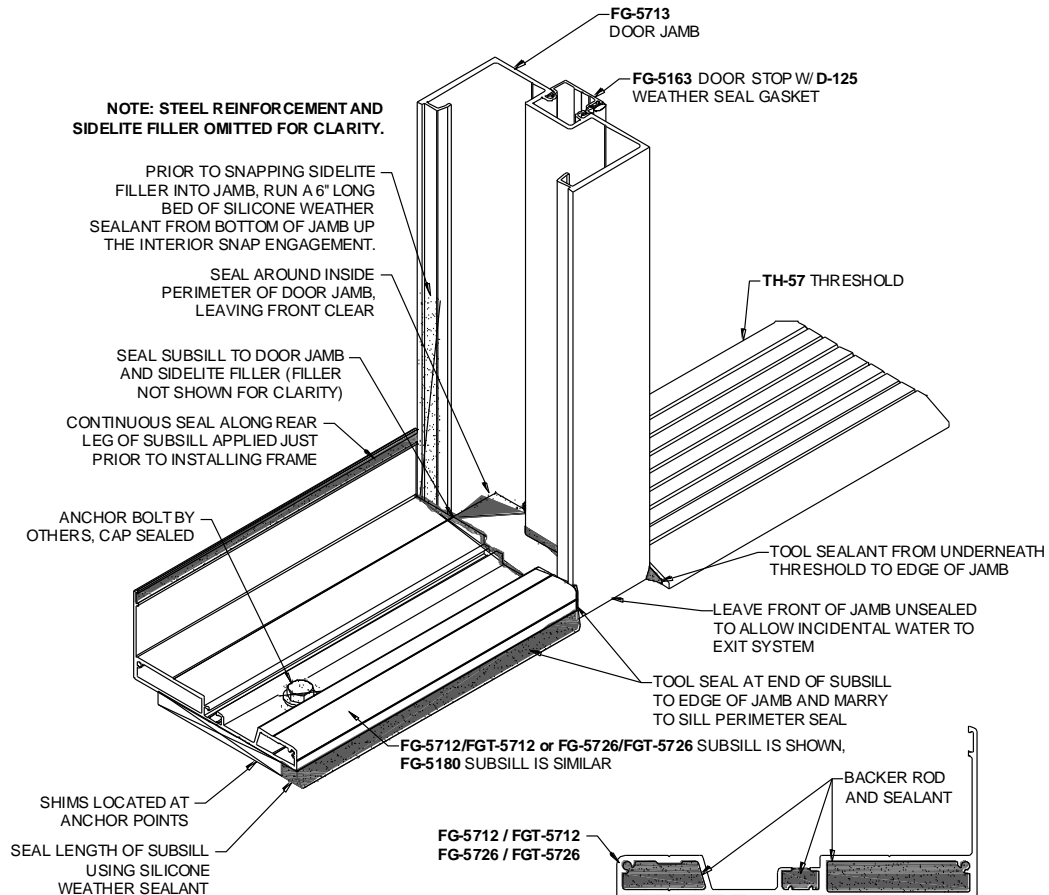

Figure 23: Sidelite Installation

9.0 Installing Door Subframe at StormMax® Curtain Walls

NOTE: All Door Subframe components are shipped factory fabricated. The main Curtain Wall framing may be erected prior to installing doors.

- 9.1 Curtain Wall Subframes are designed to anchor to Horizontals and Vertical Mullions. Both Jamb Subframes and abutting Curtain Wall Vertical Mullions run to the slab and Door Header Subframes run between. Assemble Subframe, including Threshold, per *Section 6.0*.
- 9.2 Measure assembled Subframe diagonally from corner to corner on both sides to check frame squareness. Adjust as needed until square.

MSD-375/WSD-500 StormMax® Entrance Installation and Glazing Manual

9.3 The Threshold Anchor Plate may be used in pieces at anchor bolt locations only (as **FG5000-FP-19**), or it may be used continuously (as extrusion **TH-60**). The Plate, whether continuous or in pieces, does not attach to the floor substrate. The Anchor Plate is used to ensure anchor bolts do not bend under load. Plate(s) should be drilled for a clear hole at each anchor bolt location. The Plate(s) may be either pre-located on the floor substrate or taped in place or secured via silicone sealant to underside of Threshold to facilitate installation. If pre-located on floor substrate, the centerline of the Plate will be set back 2-17/32" from leading edge of Jamb Subframe. Reference Figure 24. Anchor bolt size, quantities, and layout to be determined via structural review. Refer to approved shop drawings.

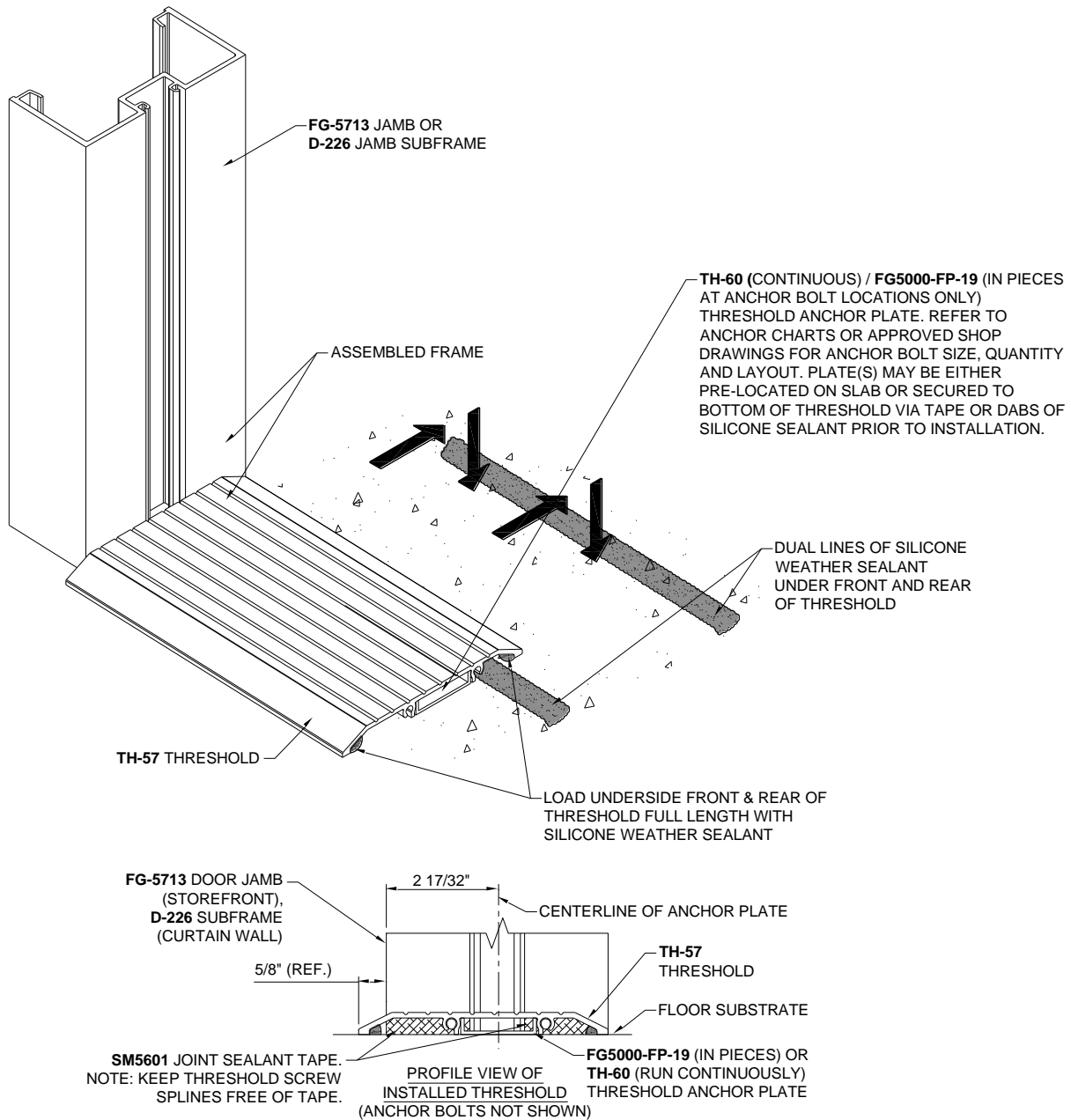

Figure 24: Subframe Installation

MSD-375/WSD-500 StormMax® Entrance Installation and Glazing Manual

- 9.4 Front of Jamb Subframe will be located flush with the leading edge of the framing system's Pocket Filler. Reference Figure 26 for alignment.
Note: A 1/8" shim space is required at Jamb Subframes while Header Subframes require 1/4" of shim space.
- 9.5 Create dual beds of sealant on substrate along both the interior and exterior edges of Threshold location. Also, fill voids on the underside of Threshold front & rear with weather sealant. Do not allow sealant to skin over before proceeding to next step.
- 9.6 Create bed of sealant where Vertical Mullion and Jamb Subframe will contact substrate and butter bottom ends with sealant. Do not allow sealant to skin over before installation.
- 9.7 Install assembled frame. Reference Figure 24.
- 9.8 Anchor Threshold through Anchor Plate(s) and into floor substrate with flat head anchor bolts per anchor charts or approved shop drawings.
- 9.9 Wipe away excess sealant from Threshold and Mullion/ Jamb Subframe locations immediately after installing. Exposed front ends of Threshold must be sealed after Subframe installation to prevent water encroachment under the Threshold and into the building or substrate. Reference Figure 25.

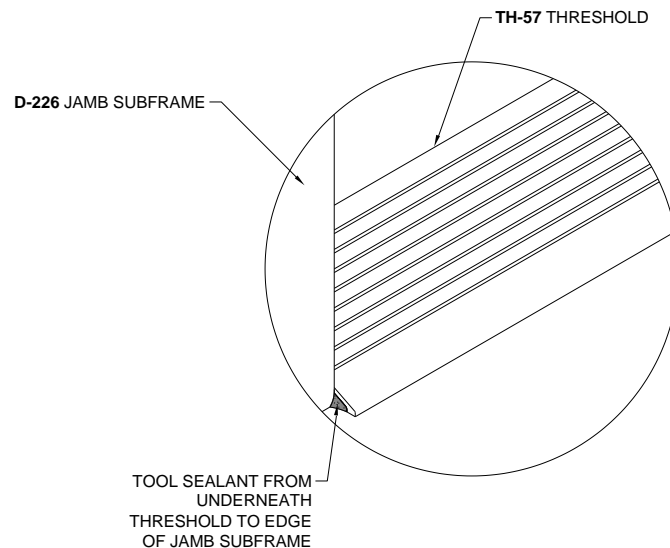

Figure 25: Seal at Front of Threshold

- 9.10 For installation of Door Stops, reference guide in *10.0 Installing Door Stops*.
- 9.11 Shim and attach assembled Subframe to Curtain Wall members per the following:
Note: Stagger screws as necessary to avoid interference with other fasteners.
- 9.11.1 Reliance™ StormMax® and Reliance™ StormMax® High Performance:
9.11.1.1 Attach Header and Jamb Subframes with **FS-325** at 18" on center or per engineering review.
- 9.12 Seal the shim space both interior and exterior per Figure 26.

MSD-375/WSD-500 StormMax® Entrance Installation and Glazing Manual

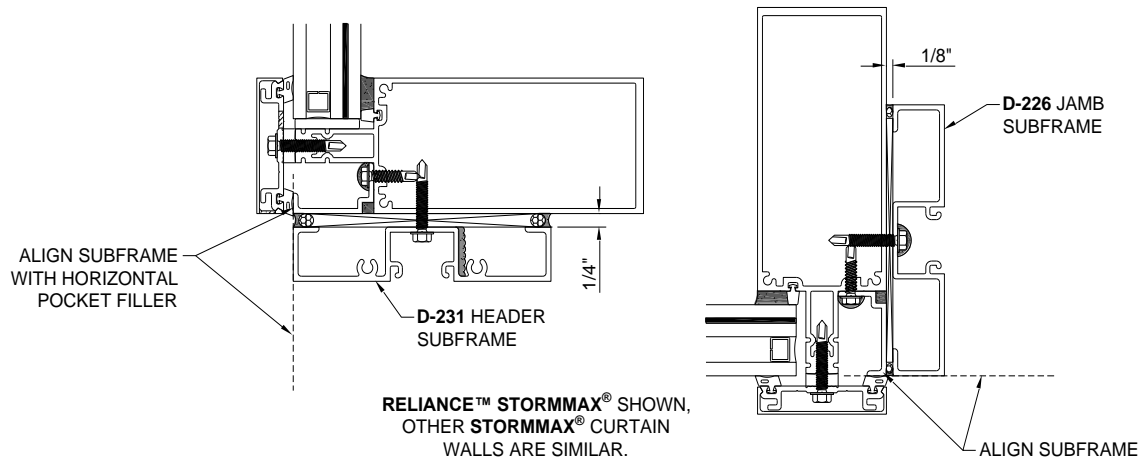

Figure 26: StormMax® Curtain Wall Subframe Alignment, Shimming and Sealing

10.0 Installing Door Stops

Door Stops are determined by the hinge type. Verify the Door Stop received matches with the hinge type of the door to be installed. Apart from the Concealed Closer Door Stop **DS-104**, vertical Door Stops run through and horizontal Door Stops run between; all vertical Door Stops butt into the Threshold. Reference 1.0 *Establish Material Size* to verify cut lengths of material before installation.

Hinge Type & Location	Door Stop Installation
Butt Hinge	FG-5163
Gear Hinge (Header, Lock Jamb)	FG-5163
Gear Hinge (Hinge Jamb)	FG-5222 + FG-5223
Offset Pivot	FG-5163
Concealed Closer Header	DS-104 + SC-1 Spring Clip

10.1 **FG-5163** Door Stop

- 10.1.1 Cut **D-125** Weather Seal Gasket to Door Stop Length. Slide into the gasket track of the Door Stop and stake at each end to secure.
- 10.1.2 Insert front leg of Door Stop into the front snap track and rotate back leg into the back snap.
- 10.1.3 Carefully, strike Door Stop with a dead-blow hammer to snap Stop into place.
- 10.1.4 Mask off Door Stop and Door Jamb with 1" wide (minimum) low-adhesion masking tape. Reference Figure 27 for masking tape application location.
- 10.1.5 Apply a thin bead of silicone weather sealant to the joint, taking care not to leave any voids or air bubbles. Immediately tool, creating a smooth and finished joint.
- 10.1.6 Remove masking tape before sealant skins, taking care not to damage tooled sealant.

MSD-375/WSD-500 StormMax® Entrance Installation and Glazing Manual

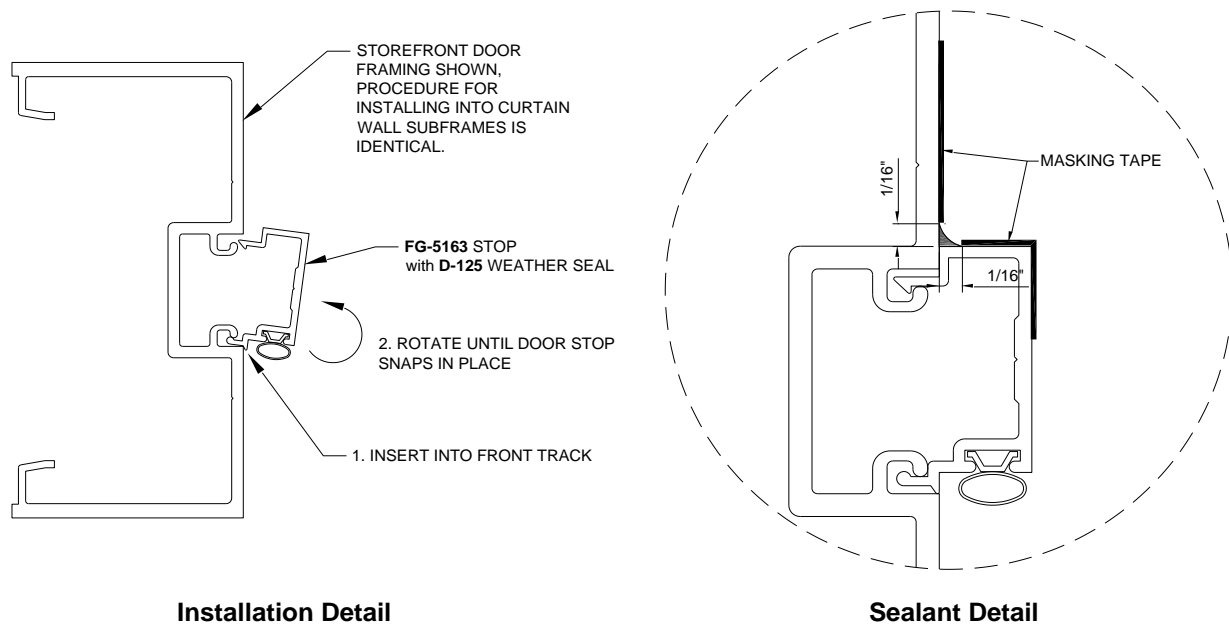

Figure 27: FG-5163 Door Stop Installation and Sealant

10.2 **FG-5222 with FG-5223 Two-Piece Door Stop**

When installing a Continuous Gear Hinge, a two-piece Door Stop is required at the hinge Jamb. The Door Stop is comprised of the **FG-5222** Door Stop Base and the **FG-5223** Door Stop Cover.

- 10.2.1 To install the **FG-5222** Door Stop Base, insert the front leg into the front snap track and rotate Door Stop Base into the back snap. See Figure 28 for visual.
- 10.2.2 Secure Door Stop Base to the **FG-5713** Door Jamb with **FS-115** at 18" on center intervals. Secure to **D-226** Curtain Wall Subframe with **FS-258** at 18" on center.
Note: It may be necessary to fabricate a clear hole in the side of the curtain wall Mullion to accommodate FS-258.
- 10.2.3 Cut **D-125** Weather Seal Gasket to Door Stop Length. Slide into the gasket track of the **FG-5223** Door Stop Cover and stake at each end to secure.
- 10.2.4 Slide the **FG-5223** Door Stop Cover over the Door Stop Base.
- 10.2.5 Secure Door Stop Cover to the Door Stop Base with **FS-57** at 12" on center intervals.
- 10.2.6 Mask off Door Stop and Door Jamb with 1" wide (minimum) low-adhesion masking tape. Reference Figure 27 for masking tape application location.
- 10.2.7 Apply a thin bead of silicone weather sealant to the joint, taking care not to leave any voids or air bubbles. Immediately tool, creating a smooth and finished joint.
- 10.2.8 Remove masking tape before sealant skins, taking care not to damage tooled sealant.

MSD-375/WSD-500 StormMax® Entrance Installation and Glazing Manual

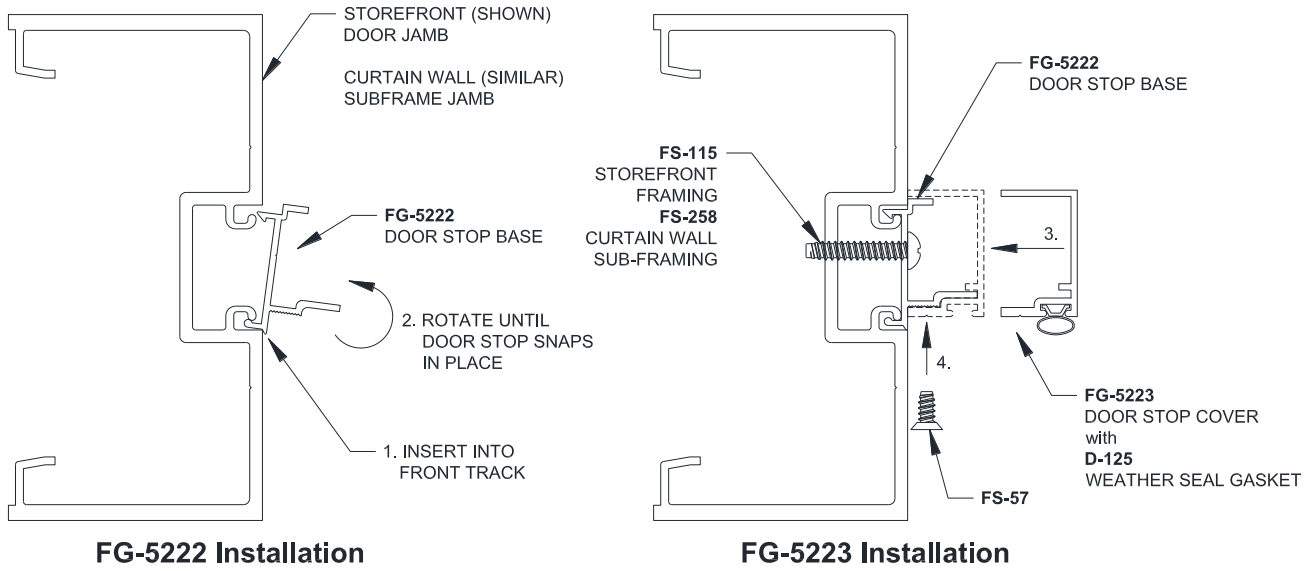

Figure 28: Attaching Two-Piece Door Stop to Door Jamb

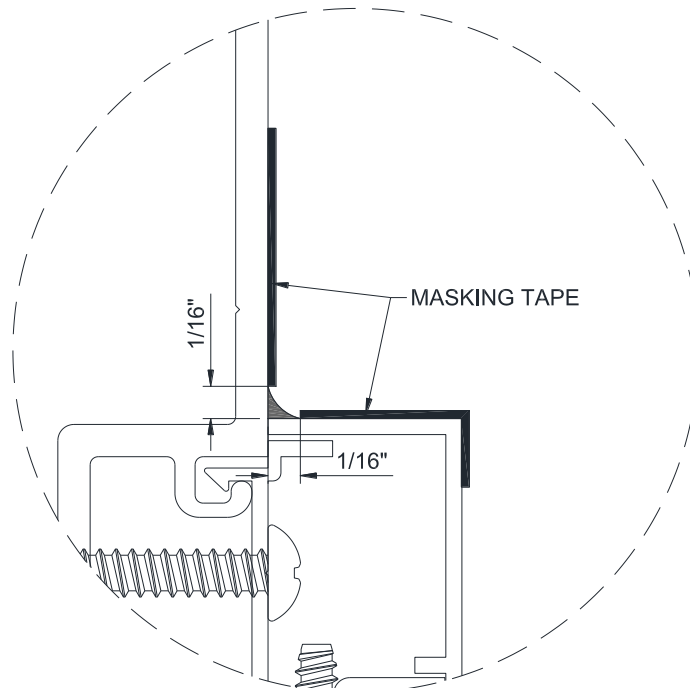

Figure 29: Sealing Two-Piece Door Stop and Door Jamb

MSD-375/WSD-500 StormMax® Entrance Installation and Glazing Manual

10.3 **DS-104** with **SC-1** Spring Clip

Reference *Figure 30* for procedures outlined below.

- 10.3.1 Cut **D-125** Weather Seal Gasket to door stop length. Pre-install by sliding into the gasket track of the Door Stop and staking at each end to secure.
- 10.3.2 Install **SC-1** Spring Clip to underside of the Concealed Overhead Closer Door Header. Use **FS-15** Drive Rivets to secure.
- 10.3.3 Using a dead blow hammer, gently snap the **DS-104** Door Stop over the Spring Clip.
- 10.3.4 At pairs, anchor the **DS-104** to the door Header with a single **FS-201** fastener located at centerline of door opening.
- 10.3.5 Mask off Door Stop and Door Jamb with 1" wide (minimum) low-adhesion masking tape.
- 10.3.6 Apply a thin bead of silicone weather sealant to the joint, taking care not to leave any voids or air bubbles. Immediately tool, creating a smooth and finished joint.
- 10.3.7 Remove masking tape before sealant skins, taking care not to damage tooled sealant.

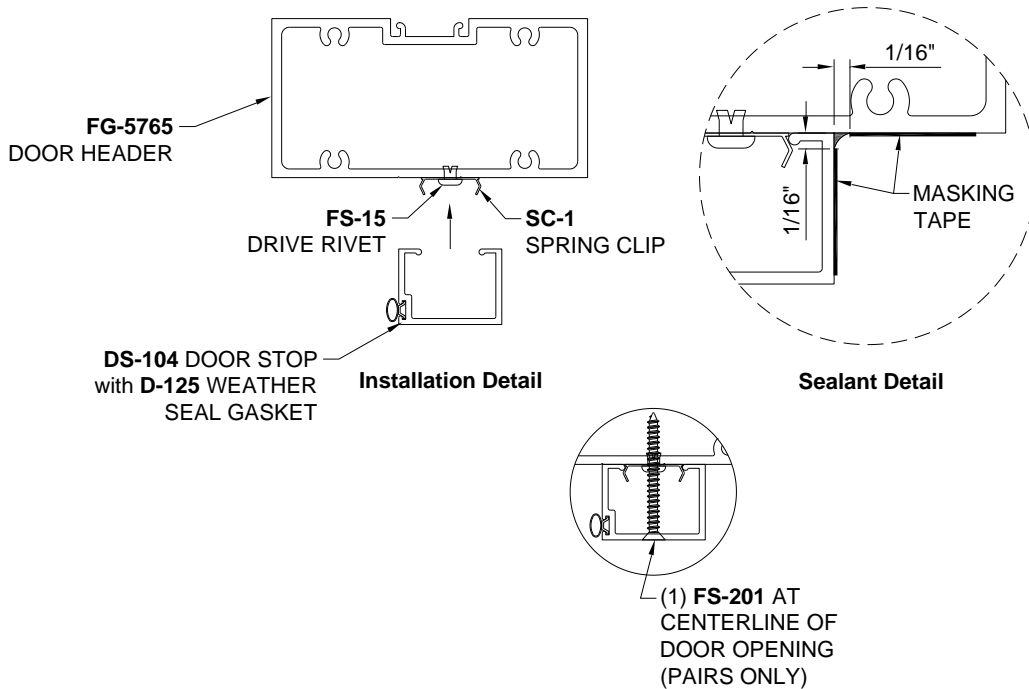

Figure 30: Attaching Door Stop to Concealed Closer Header and Sealing

MSD-375/WSD-500 StormMax® Entrance Installation and Glazing Manual

11.0 Installing Transom Sash

StormMax® Storefront entrance installations that require a Transom will need specific Sash inserts to accommodate Transom Glazing.

Transom Sash and Transom Sash Stops are cut to length and prepped at the factory. Verify the lengths required per *1.0 Establish Material Size*.

FG-5700 StormMax®

FG-5750 StormMax®

FG-5750T StormMax®

• FG-5198 Transom Sash

• FG-5181 Transom Sash

• FG-5181 Transom Sash

Note: When a transom head requiring a glass stop is used (**FG-5710** for FG-5700 and **FG-5760** for FG-5750/5750T), the vertical transom sashes require special fabrication at the top front corner to allow clearance for horizontal glass stop installation. A 1/2" x 1/2" 45 degree cut will be sufficient. This may be performed in the shop or in the field, so long as it is done before installing sash. Note that the sash stops do not require this prep. Reference Figure 31.

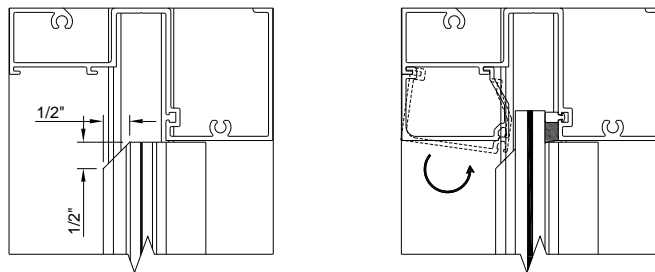

Figure 31: Special Fabrication at Vertical Transom Sashes

- 11.1 Snap Transom Sash into the Door Stop track of the Door Jamb or Concealed Closer Header.
- 11.2 Secure Transom Sash with **FS-6** fasteners at 12" intervals on center. Cap seal fasteners. Reference Figure 32.
- 11.3 Mask off Transom Sash and Door Jamb with 1" wide (minimum) low-adhesion masking tape. Reference Figure 33 for masking tape application location.
- 11.4 Apply a thin bead of silicone weather sealant to the joint, taking care not to leave any voids or air bubbles. Immediately tool, creating a smooth and finished joint, Figure 31.
- 11.5 Remove masking tape before sealant skins, taking care not to damage tooled sealant.

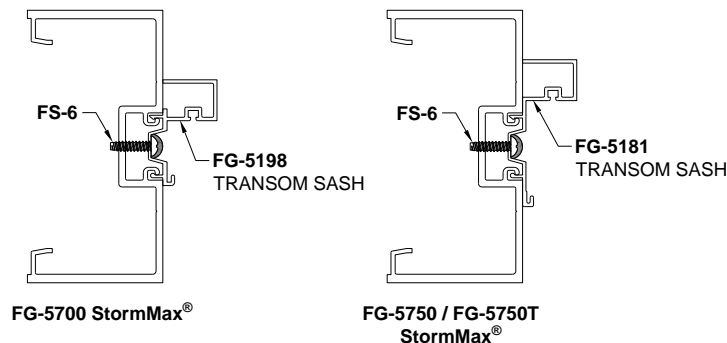

Figure 32: Attaching Transom Sash

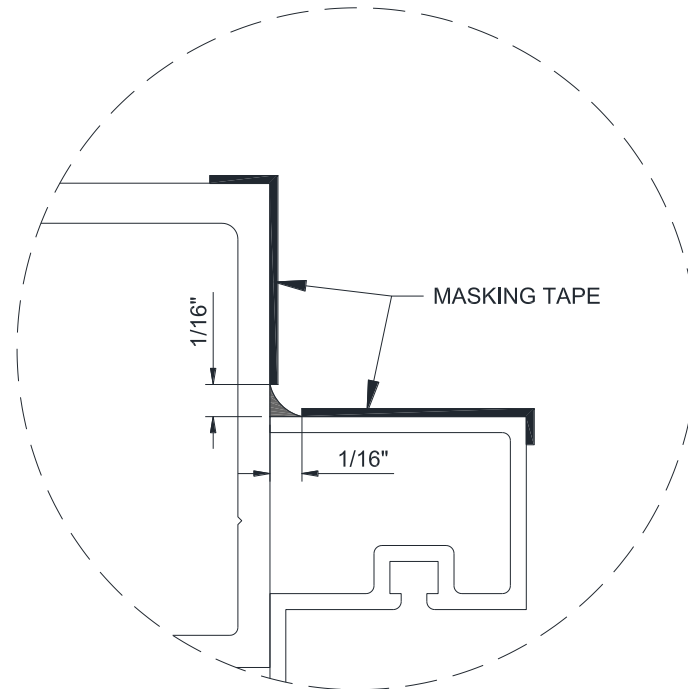

Figure 33: Interior Seal along Sashes

GLAZING

12.0 Glass Sizing

12.1 Door Glass Sizing

The MSD-375/WSD-500 StormMax® entrance is designed and tested for optimal performance using 9/16" monolithic laminated glazing and is also approved for use with 1" insulating laminated glazing.

When ordering the desired glass, reference Figure 34 and use the following formulas:

- GLASS WIDTH: Glass Opening minus (-) 7/16"
- GLASS HEIGHT: Glass Opening minus (-) 7/16"

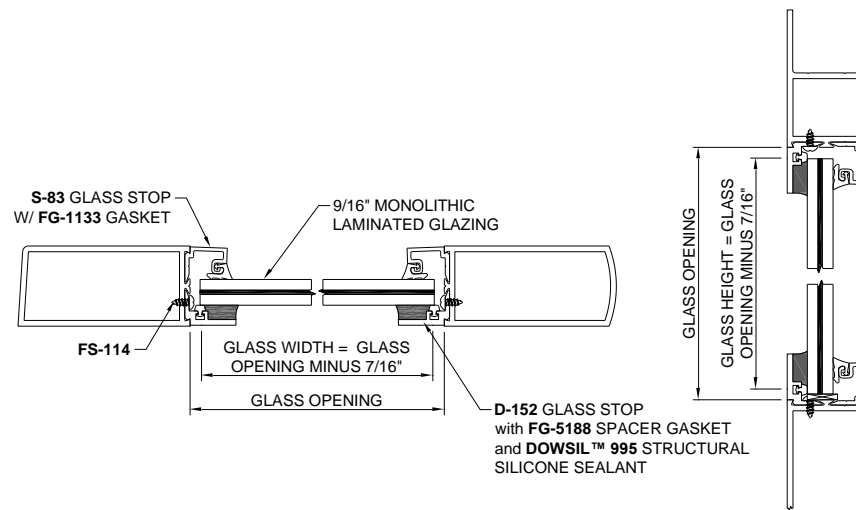

Figure 34: Determining Glass Size for Doors

MSD-375/WSD-500 StormMax® Entrance Installation and Glazing Manual

12.2 Transom Glass Sizing

Transom Glass Size varies depending on the system, condition and members used. See the below guide and reference Figure 35 and Figure 36 to determine sizing.

Note: Figures below show Transom in FG-5700 StormMax® Framing. Transom in FG-5750 StormMax® and FG-5750T StormMax® Framing is similar.

FG-5700 StormMax® Framing

- GLASS WIDTH: Transom D.L.O plus (+) 1-1/8"
- GLASS HEIGHT:
 - Surface Closer:
Frame D.L.O. plus (+) 1-3/16"
Note: 5/8" Glass Bite at Door Header
 - Concealed Closer:
Transom D.L.O. plus (+) 1-1/8"

FG-5750 StormMax® Framing or FG-5750T StormMax® Framing

- GLASS WIDTH: Transom D.L.O plus (+) 1-1/8"
- GLASS HEIGHT:
 - Surface Closer:
Frame D.L.O. plus (+) 1-1/8"
 - Concealed Closer:
Transom D.L.O. plus (+) 1-3/16"
Note: 5/8" Glass Bite at Door Header

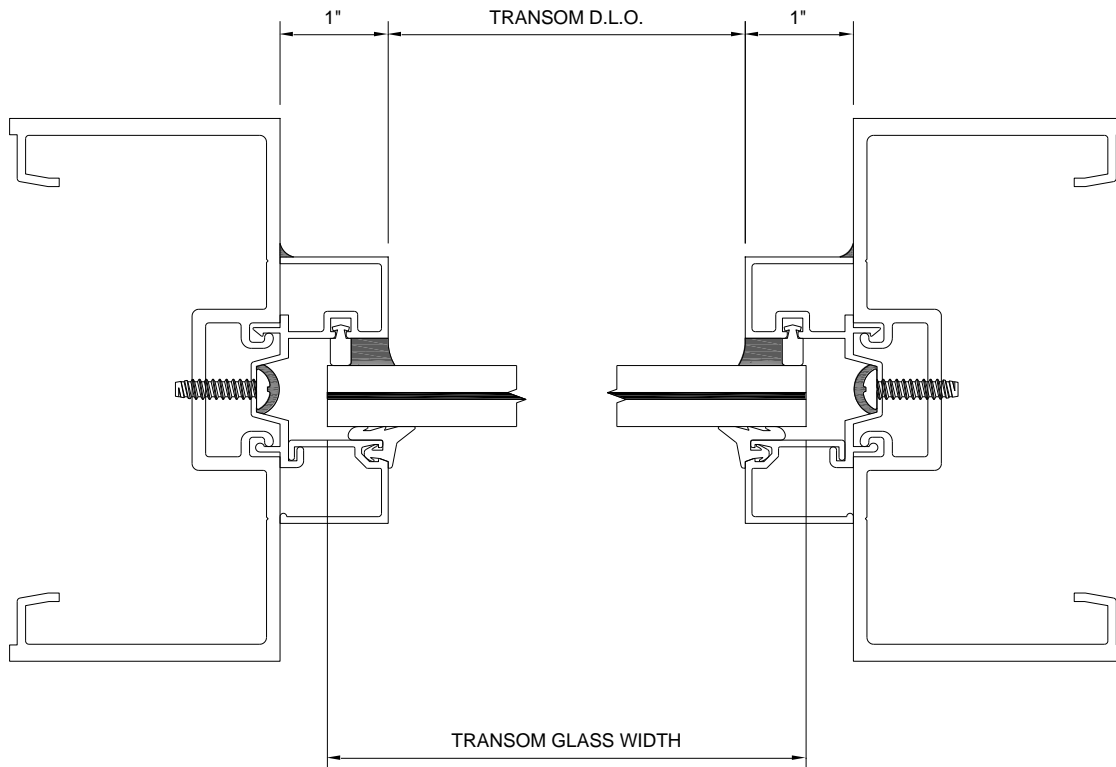

Figure 35: Horizontal Transom Glass Sizing

MSD-375/WSD-500 StormMax® Entrance Installation and Glazing Manual

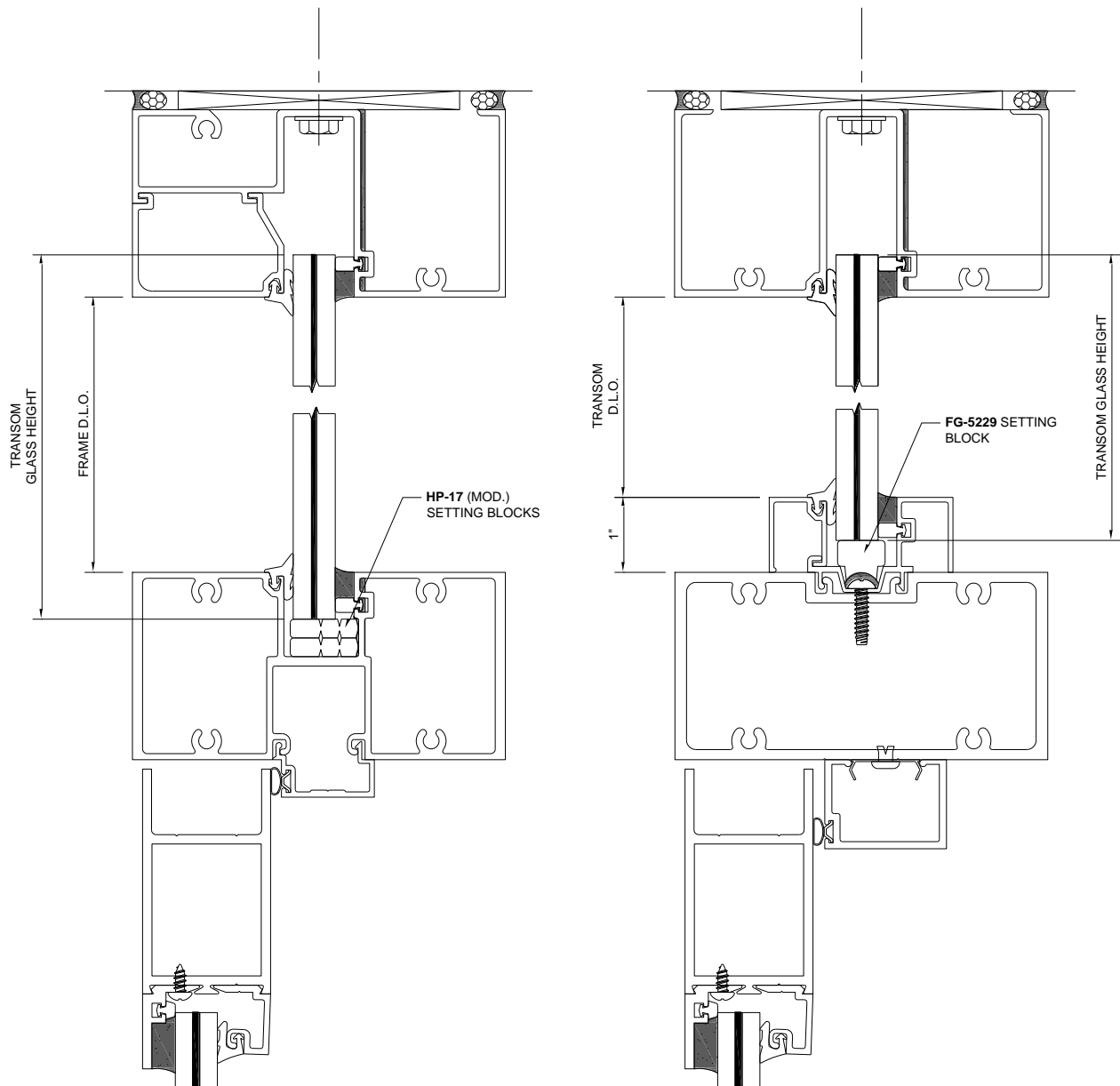

Figure 36: Vertical Transom Glass Sizing

MSD-375/WSD-500 StormMax® Entrance Installation and Glazing Manual

13.0 Glazing the Door

13.1 Glazing Practices

The air and water performance of the framing system is directly related to the completeness and integrity of the installation process, including but not limited to the assembly seals of the framing joinery, the installed glazing gaskets, and the alignment of the framing joinery glazing plane. Before glazing, verify the glazing pocket width and glazing infill thickness, as both must be in tolerance to assure adequate edge pressure and to achieve the desired air and water performance levels. (In general, framing systems utilizing 1" insulating glass are designed to accommodate a thickness variance of +/- 1/32"). Note: Excessive pressure can cause glass breakage and/or IGU failure. Consult the glass manufacturer for their recommended edge pressure per lineal inch.

To achieve the designed and tested air and water performance, best practices include:

- Glazing gaskets should be cut 1/4" longer per foot, and lay flat, preferably for 24 hours.
- Gaskets should be cut as single monolithic pieces and "crowded" during their installation to avoid corner gaps caused by post-installation relaxation.
- The interior glazing gasket should be installed so as to avoid stretching, buckles, or tears
- Corners must be cut square, and at a slight angle when required to conform to the bevel on the intersecting gasket; sealed and butted together.
- Gasket corner joinery must also be crowded, and sealant applied onto the gasket contact frame surface and into gasket reglet raceway where applicable.
- Gasket corner seals are to be done just prior to installing glass, while the sealant is still wet and uncured, and ensure exterior gaskets are installed so as to place the glass into it's final in service condition and allow the sealant to conform to optimum configuration. Note: If the sealant cures prior to glazing, the cured sealant could create excessive edge pressure onto the glass and has the potential to cause glass breakage.
- The glass must be checked for squareness, size dimension, and thickness along the edges paying attention to any variances from center edge to corner edge.
- Check the placement of the installed glass and verify there is proper edge bite into the pocket, and proper edge clearance from framing elements.

After sealant has set and a representative amount of the wall has been installed and glazed (250 square feet or more) run a water hose test in accordance with AAMA 501.2 specifications to check installation. On large projects the hose test should be repeated during the glazing operation. Consult and follow NGA's GANA Manual and FGMA Glazing Manual for proper glazing technique and procedure.

MSD-375/WSD-500 StormMax® Entrance Installation and Glazing Manual

13.2 Preparing Door for Glazing

All glazing materials are shipped separately in the Frame Box. Verify all required parts arrived. MSD-375/WSD-500 StormMax® entrance is designed to be glazed with the **D-152** Glass Stop installed for wet glazing on the exterior of the entrance. Optionally

13.2.1 Door may have **D-152** Glass Stop factory installed. If it is not, match-drill the rails of the door with the factory-created pilot holes in **D-152**, taking care not to damage the pre-installed **FG-5188** Spacer Gasket. Attach the **D-152** Glass Stop to the door with **FS-114** fasteners. Reference Figure 37.

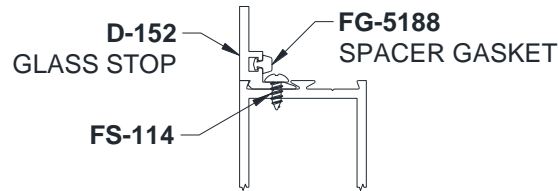

Figure 37: Installing D-152 Glass Stop

13.2.2 Install **FG5000-PP-1** or **D-123** Setting Blocks / Side Blocks per Figure 38. The blocks are adhesive backed for easy installation. Blocks may be doubled as required to compensate for glass tolerances.

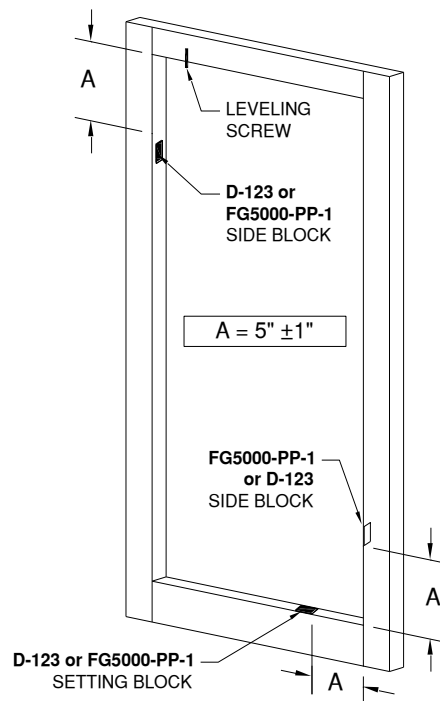

Figure 38: Locating Setting Blocks / Side Blocks

MSD-375/WSD-500 StormMax® Entrance Installation and Glazing Manual

13.3 Cut Gasket to Length

13.3.1 Cut the **FG-1133** Gasket to a minimum length of Glass Opening plus (+) 1/4" per foot.

13.3.2 Miter the horizontal Gaskets per Figure 39.

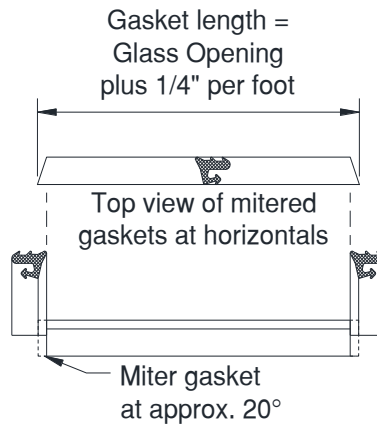

Figure 39: Gasket Cut Guide

13.4 Setting Glass

13.4.1 Center glass in the opening on the Setting Block, ensuring glass is pressed uniformly against the **FG-5188** Spacer Gasket.

13.4.2 Once the glass is in the correct position, tighten the Glass Leveling Screw down to the top of the glass just enough to hold the glass in place.

13.4.3 Square the door. Measure the Door Leaf in a diagonal corner-to-corner method and adjust the Glass Leveling Screw as needed until the door is square.

13.4.4 Install the **S-81** or **S-83** Glass Stop into the Door Rail. Hook the stop into the dovetail on the Rail and snap into place, as shown in Figure 40.

NOTE: The top rail Glass Stops are notched to clear the Leveling Screw.

13.4.5 After the horizontal Glass Stops are installed, install the vertical Stops using the same method.

13.4.6 Press the **FG-1133** Gasket into the reglets in **S-83**, installing vertical Gaskets first, then horizontal Gaskets, as shown in Figure 41. The **S-81** stop will have **V-28** gasket pre-installed.

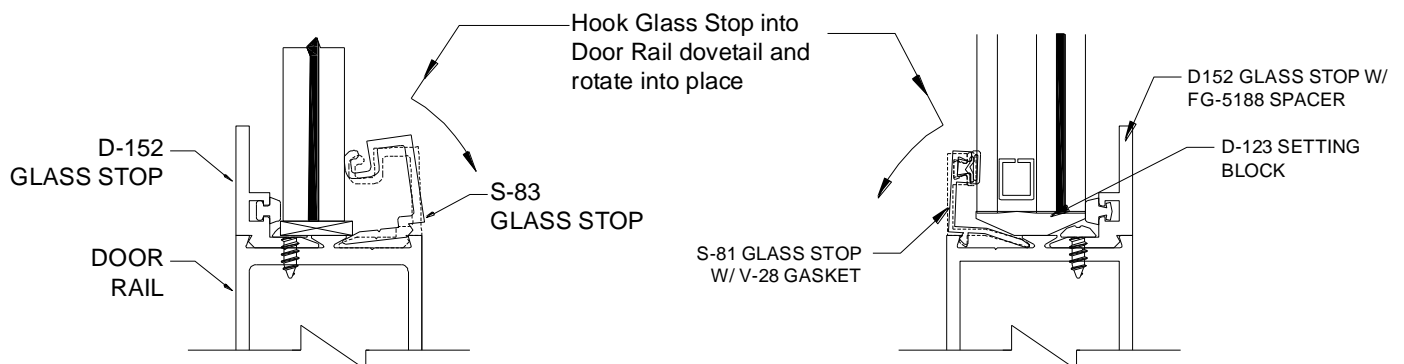

Figure 40: Installing S-81 and S-83 Glass Stop

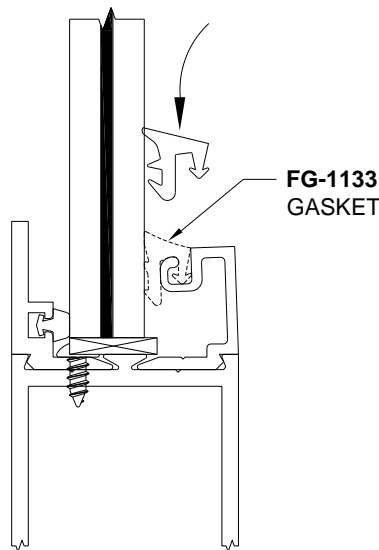

Figure 41: Installing FG-1133 Gasket

13.5 Application of Structural Sealant

- 13.5.1 Verify that the door is square. Measure the Door Leaf in a diagonal corner-to-corner method and adjust the Glass Leveling Screw as needed until the door is square.
- 13.5.2 Clean glass with isopropyl alcohol and mask off glass with 1" wide (minimum) low-adhesion masking tape. For masking tape application location, reference Figure 42.
- 13.5.3 Fill the cavity between the glass and the **D-152 Glass Stop** with **DOWSIL™ 995 Structural Silicone Sealant**, as shown in Figure 42 enlarged detail. Care should be taken not to leave any voids and to eliminate air bubbles in the sealant. Immediately tool, creating a finished joint with a slight beveled/curved joint surface.
- 13.5.4 Remove masking tape before sealant skins, taking care not to damage tooled sealant.

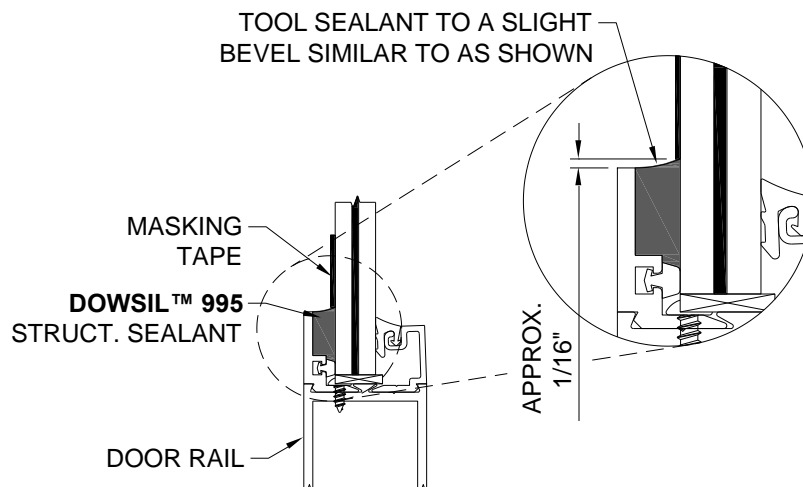

Figure 42: Wet Glazing Exterior of Door

MSD-375/WSD-500 StormMax® Entrance Installation and Glazing Manual

14.0 Transom Glazing

Note: Transoms are approved for wet glazed, exterior set installations only.

The procedure for installing the MSD-375/WSD-500 StormMax® entrance with a Transom in FG-5700 StormMax® storefront framing and in FG-5750 StormMax® storefront framing is the same. The two full assemblies are shown in Figure 43 and Figure 44, depicting the Concealed Closer and Surface Closer options. Reference the product web details, approved shop drawings, and job specific details when glazing transoms.

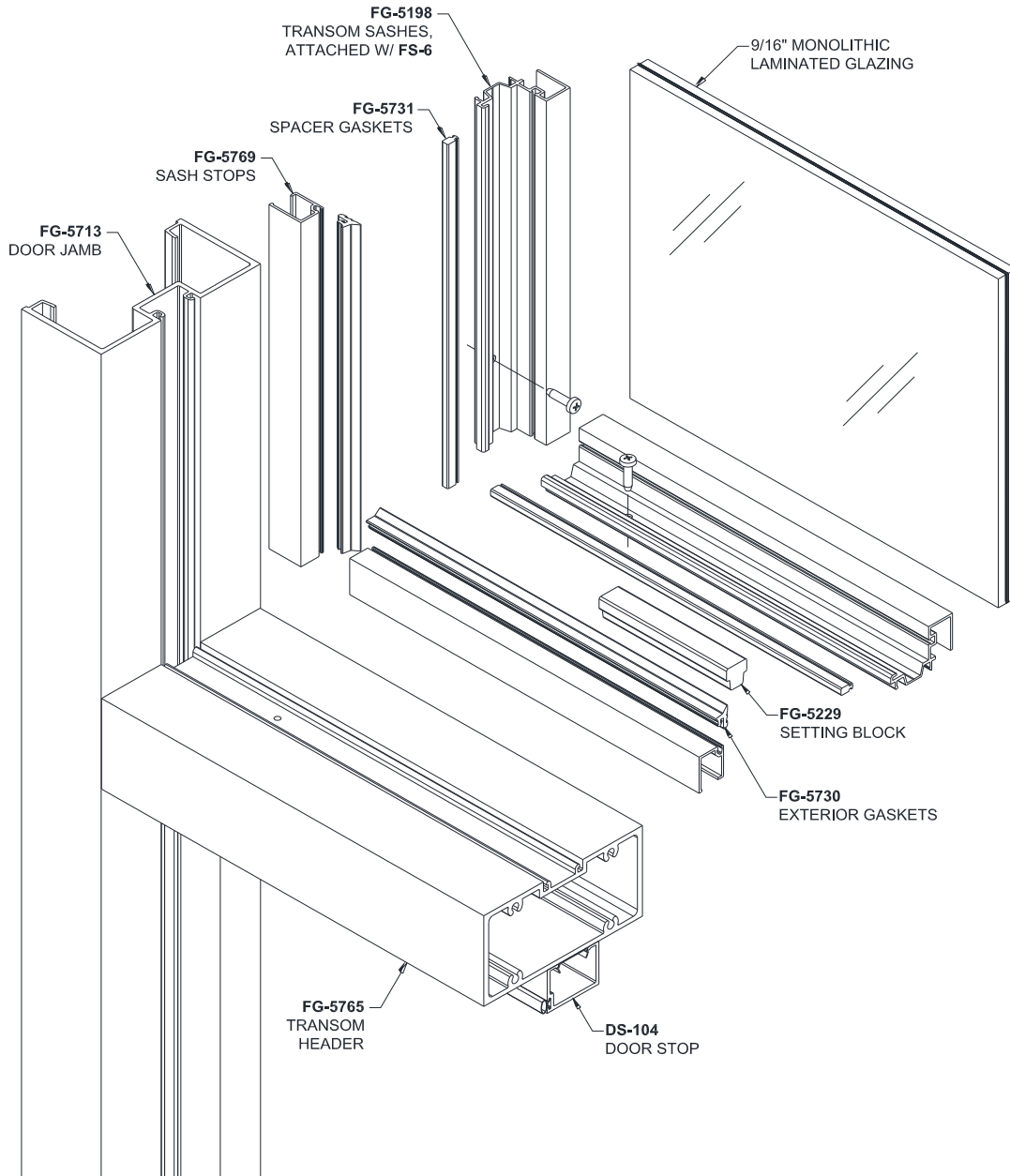

Figure 43: FG-5700 StormMax® Assembly at Transom for Concealed Closer (FG-5750 StormMax® Similar)

MSD-375/WSD-500 StormMax® Entrance Installation and Glazing Manual

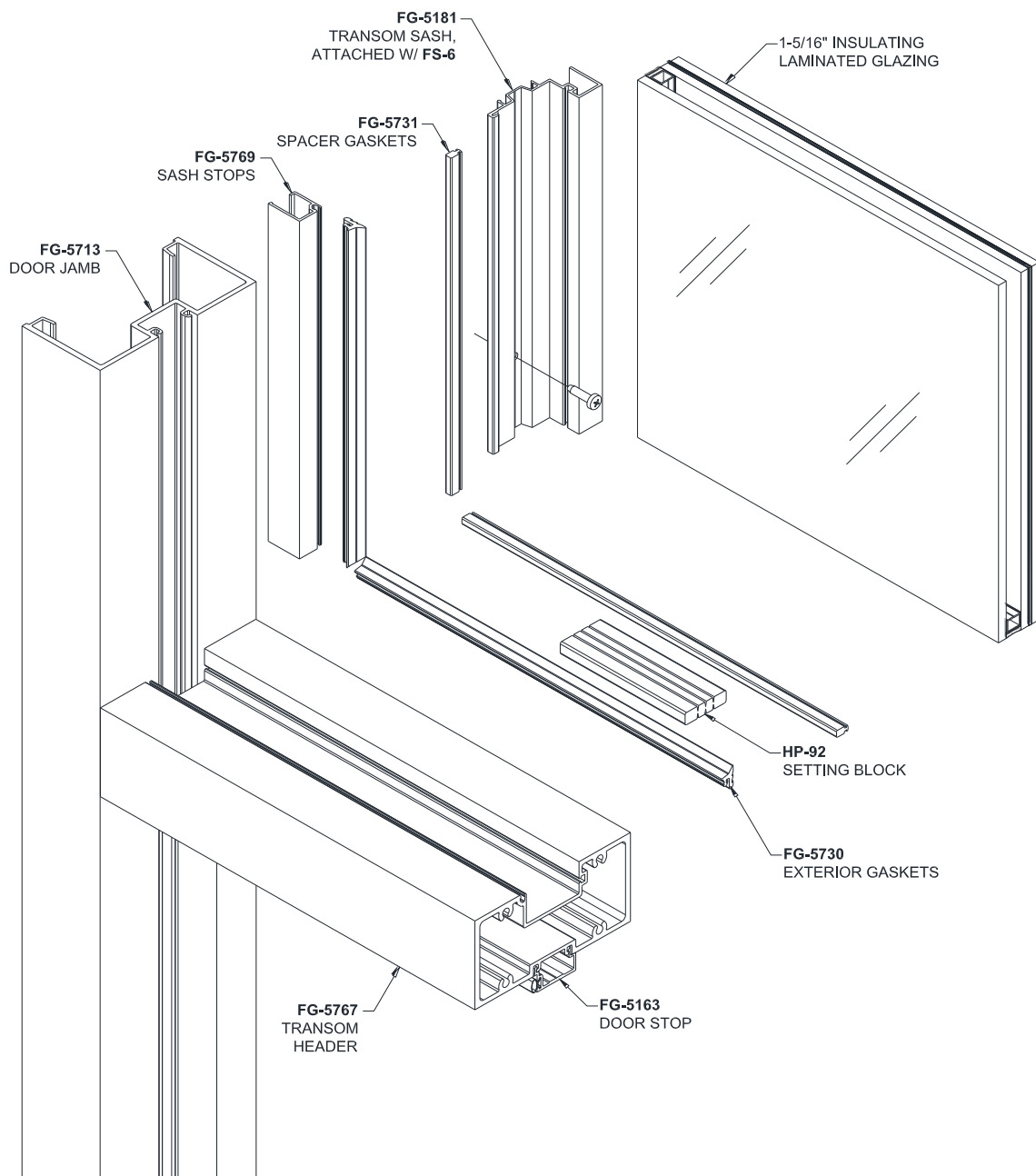

Figure 44: FG-5750 StormMax® Assembly at Transom for Surface Closer (FG-5700 StormMax® Similar)

14.1 Preparing and Installing Interior Gasket

- 14.1.1 Remove **FG-5731** Spacer Gasket from roll and allow to relax in a protected location overnight.
- 14.1.2 Cut Gasket to length of the Door Header, Transom Head and/or Transom Sashes plus 1/4" per foot.
- 14.1.3 Install Setting Blocks at quarter points of each lite of glass or as specified by glass manufacturer.
- 14.1.4 Remove all debris from glazing pockets to prevent blockage of weeps/drains.
- 14.1.5 Install **FG-5731** Spacer Gasket around the opening. Crowd gasket; do not stretch.

MSD-375/WSD-500 StormMax® Entrance Installation and Glazing Manual

14.2 Setting Glass and Installing Exterior FG-5730 Gaskets

FG-5730 Exterior Gasket Cut Lengths (Reference *Section 12.2* for pictorial definitions of D.L.O. measurements):

- **For Transoms at entrances with Surface Closers**

Glass Stop at Transom Head

Horizontal Gasket runs through

- Horizontal:

- Transom D.L.O. plus 1-1/2" plus 1/4" per foot

Note: Gasket ear may need to be trimmed to clear vertical Transom Sashes.

- Vertical:

- Frame D.L.O. plus 1/4" per foot

- **For Transoms at entrances with Concealed Closers**

Horizontal Transom Sash above Door Header and No Glass Stop at Transom Head

Horizontal Gasket at Transom Head runs through

Vertical gasket runs through at the Door Header

- Horizontal:

- Transom Sash Gasket: Transom D.L.O. plus 1/4" per foot.

- Transom Head Gasket: Transom D.L.O. plus 1-1/2" plus 1/4" per foot

Note: Gasket ear may need to be trimmed to clear vertical Transom Sashes.

- Vertical:

- Transom D.L.O. plus 3/4" plus 1/4" per foot.

14.2.1 Remove **FG-5730** Gasket from roll and allow to relax in a protected location overnight.

14.2.2 Install Glazing into framing and center in D.L.O. Once centered, lift glass and ensure Setting Blocks are located correctly and then lower, making sure glass is firmly and evenly seated against the **FG-5731** interior Spacer Gaskets.

14.2.3 Install Transom Sash Stops in the order listed below. Install by hooking the leg of the Stop over the mating leg of the Transom Sash, taking care to avoid damaging the glass. Then slide the Transom Stop back toward the exterior to lock in place. For a visual guide, reference Figure 45.

1. If Transom Head includes a Glass Stop, install Glass Stop at the Head first.

2. Install Sash Stops at the Jamb.

3. If Transom Door Header requires it, install horizontal Transom Sash.

14.2.4 Install Glass Stop per procedure outlined in the applicable storefront manual.

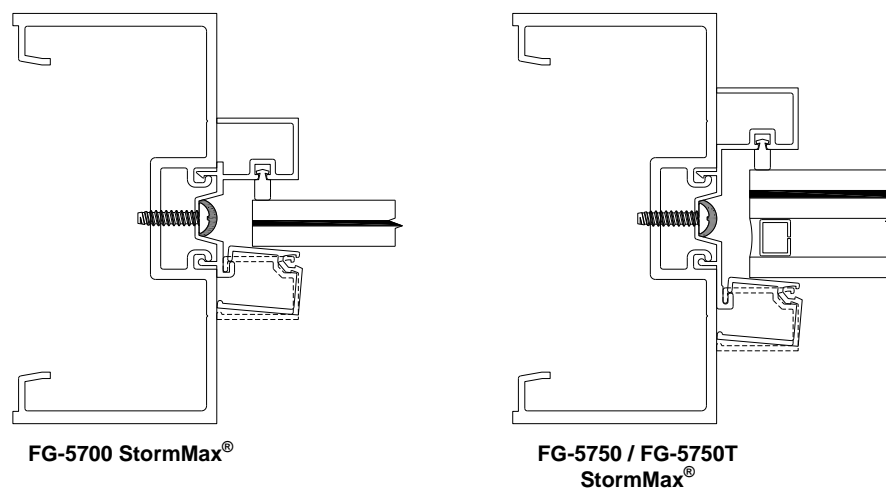

Figure 45: Transom Sash Stop Installation

MSD-375/WSD-500 StormMax® Entrance Installation and Glazing Manual

- 14.2.5 Cut the **FG-5730** Gasket a minimum of 1/4" per foot longer than the D.L.O. (see Gasket cut lengths at beginning of this section), to provide adequate compression, and miter the ends of the Gaskets at a 20° angle, as shown in Figure 46. Where horizontal Gaskets run through, miter the vertical Gasket instead of the horizontal.
- 14.2.6 Install exterior **FG-5730** Gaskets starting at the middle of the glass and working outward. Crowd Gasket; do not stretch.
- 14.2.7 After Gaskets are pressed into place, pull Gasket from pocket at corners as shown in Figure 47, *Detail A*. Clean glass and Gaskets a minimum of 2" from each end with isopropyl alcohol.
- 14.2.8 Apply silicone sealant and push Gasket back into reglet, compressing from the corner first. Reference Figure 47, *Detail B*. Clean squeeze out immediately.

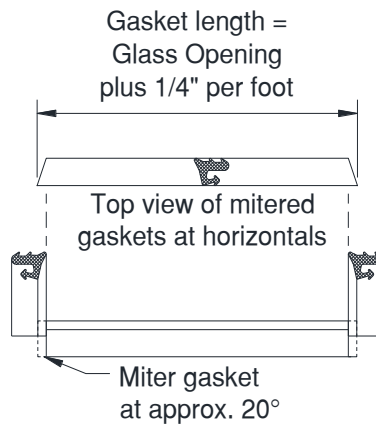
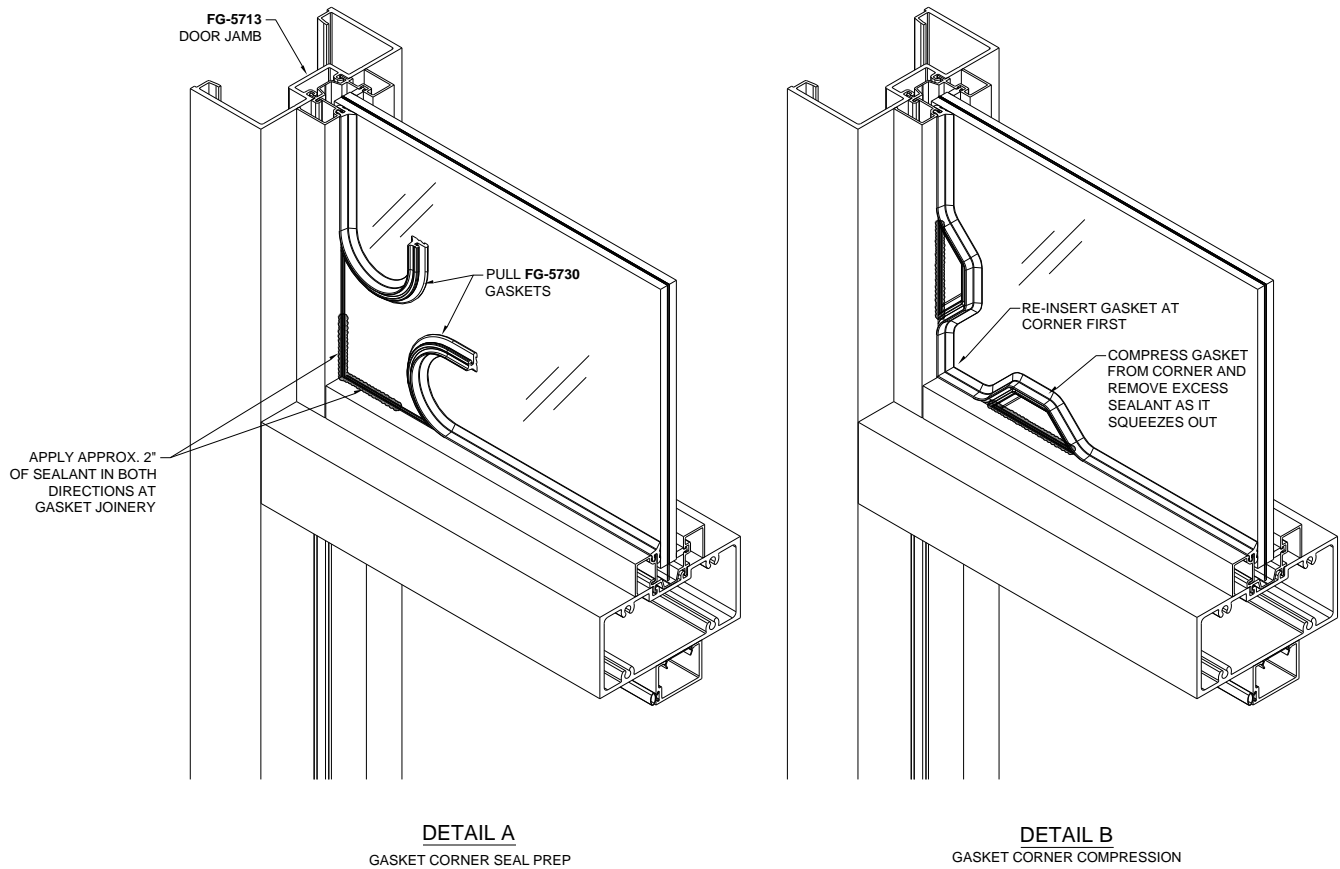

Figure 46: Gasket Cut Guide

MSD-375/WSD-500 StormMax® Entrance Installation and Glazing Manual



FG-5700 STORMMAX® WITH CONCEALED CLOSER HEADER SHOWN, BUT
PROCEDURE IS IDENTICAL REGARDLESS OF PRODUCT OR CONFIGURATION.

Figure 47: Exterior Gasket Installation

MSD-375/WSD-500 StormMax® Entrance Installation and Glazing Manual

14.3 Application of Interior Structural Sealant

- 14.3.1 Verify the glass bite is 9/16". If not, remove Exterior Gasket and return to the steps in Section 14.2.2 and adjust to attain proper glass bite.
- 14.3.2 Clean glass and Transom framing with isopropyl alcohol and mask off glass with 1" wide low-adhesion masking tape. Reference Figure 48, Detail A for masking tape application locations.
- 14.3.3 Fill cavity around full perimeter of D.L.O. with **DOWSIL™ 995** Structural Silicone Sealant, as shown in Figure 48; care should be taken not to leave any voids and eliminate air bubbles in sealant. Immediately tool, creating a finished joint with a beveled/curved joint surface as shown in Figure 48, Detail A.
- 14.3.4 Remove masking tape before sealant skins, taking care not to damage tooled sealant.

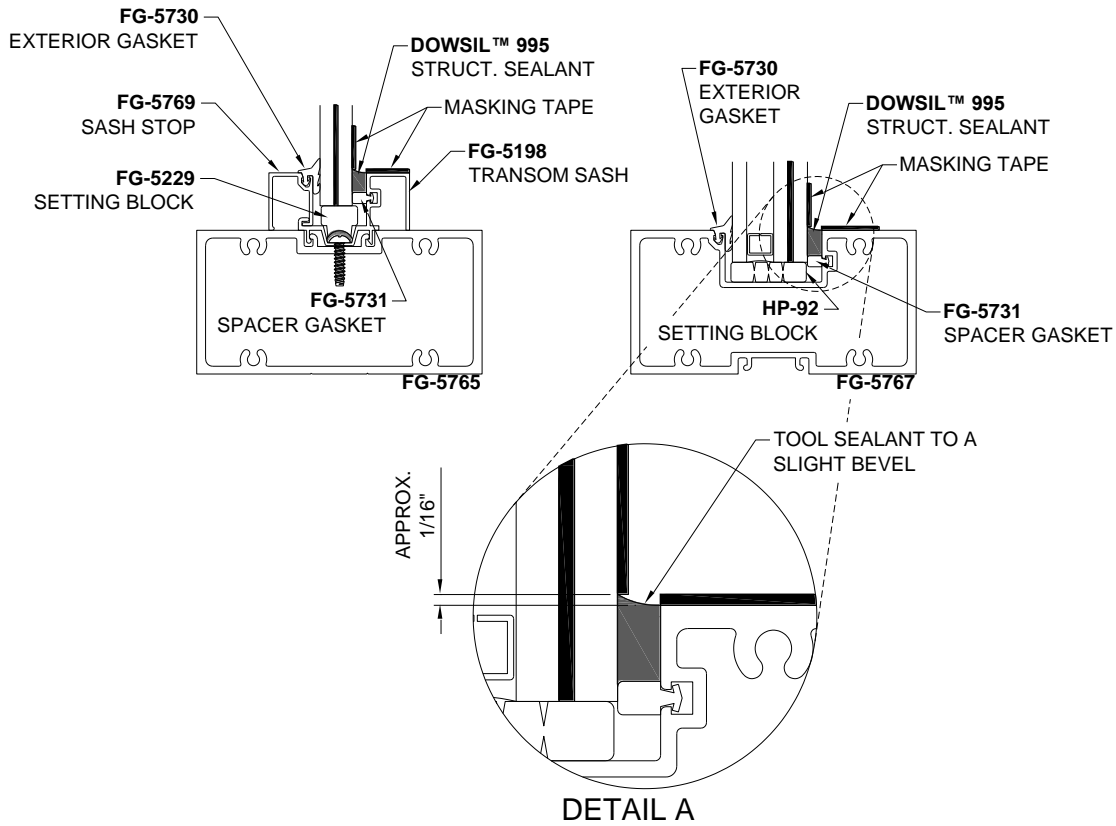

Figure 48: Wet Glazing Interior of Transom

MSD-375/WSD-500 StormMax® Entrance Installation and Glazing Manual

HANGING THE DOOR

NOTES:

- Some hardware may be factory installed for shipping purposes. Remove hardware as needed to facilitate glazing the door, taking care not to damage any parts or pieces. Re-install hardware once the door is glazed.
- Door may be glazed before or after attaching door to the frame. If the door is not pre-glazed, glaze the door before attaching hardware. It is recommended to have hardware installed before hanging.
- Back-up plates for Butt Hinges and Offset Pivots are factory installed in Frame and Hinges are factory installed to Door.
- Continuous Gear Hinge is factory installed on Door. Door Jamb is not factory-prepped to receive the Continuous Hinge.

15.0 Hanging Butt Hinge Door

- 15.1 Lift Door until Butt Hinges align with hinge cut-out in Door Jamb.
- 15.2 Block under Door when hinge aligns with cut-out.
- 15.3 Attach hinges to the back-up plates in frame using FS-22 (#12-24 x 1/2" UCPFH), as shown in Figure 49.
- 15.4 If the door mounted hinge and the frame slots are misaligned, back off the screws and re-adjust the door until it fits properly, then tighten down fasteners.
- 15.5 Continue on to 18.0 *Installing Hardware* to complete hardware installation or 19.0 *Final Adjustments to Door* to make final adjustments to the hardware.

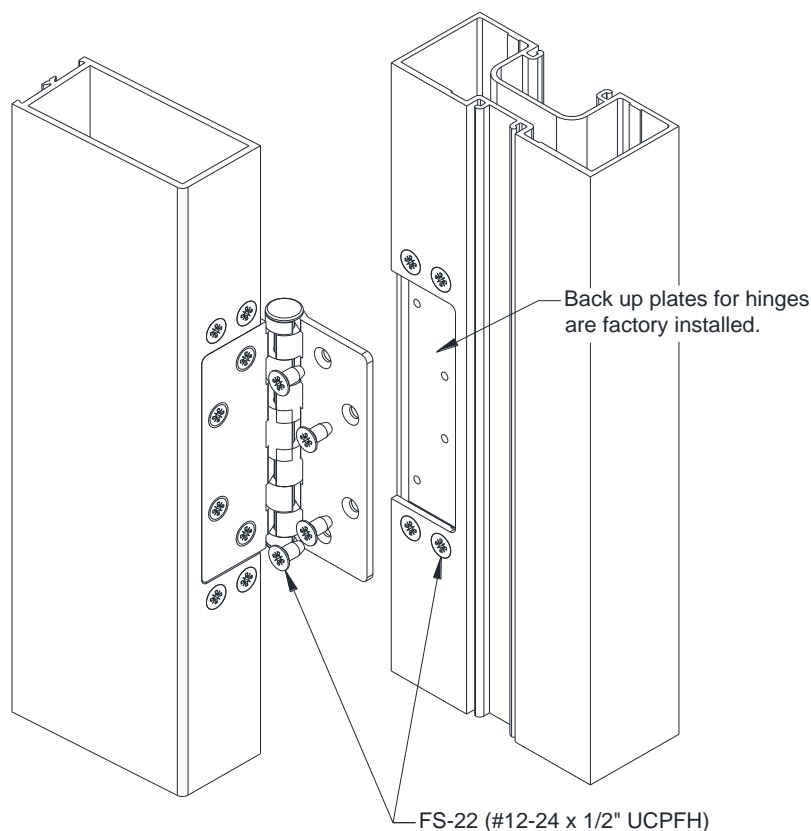

Figure 49: Hanging Door with Butt Hinges

MSD-375/WSD-500 StormMax® Entrance Installation and Glazing Manual

16.0 Hanging Offset Pivot Door

Reference Figure 50 for a visual guide to installing the pivots and hanging the door.

- 16.1 If not already pre-installed, attach bottom, intermediate, and top pivots to door leaf.
- 16.2 If not already pre-installed, attach bottom and top pivots to frame.
- 16.3 Lift door upward and tilt in open position. Set bottom pivot of door leaf over the bottom pivot pin of frame.
- 16.4 Depress pin of the top door pivot then rotate door up to plumb until door top pivot is under frame top pivot. Maneuver door into place and wiggle until door's pivot pin engages with frame's pivot.
- 16.5 Once door is engaged with top and bottom pivot, install the frame portion of the intermediate pivot. Insert pin upward to engage with door pivot and attach to backup plate with **FS-22** (#12-24 x 1/2" UCPFH).
- 16.6 Continue on to 18.0 *Installing Hardware* to complete hardware installation or 19.0 *Final Adjustments to Door* to make final adjustments to the hardware.

Note: If door needs to be uninstalled, remove the screws and uninstall the frame portion of the intermediate pivot first. Then the frame portion of the top pivot may be installed, letting the door drop. Door leaf can then be tilted out of the frame.

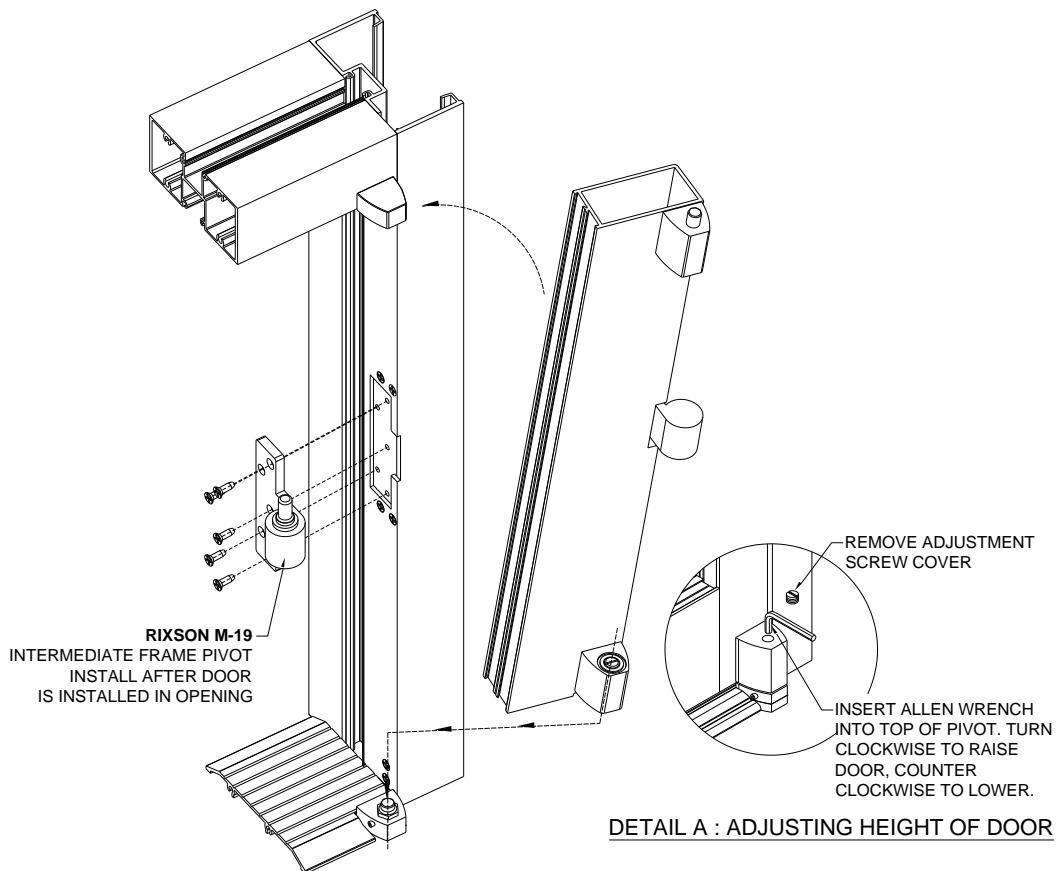

Figure 50: Hanging Door with Offset Pivots

MSD-375/WSD-500 StormMax® Entrance Installation and Glazing Manual

17.0 Hanging Gear Hinge Door

- 17.1 Place a 1/8" shim at the top of the Door Jamb at the Header to locate the top of Door.
- 17.2 Align Continuous Gear Hinge to Door Jamb by using the Locator Leg as a guide. Locator Leg is identified in Figure 51 Detail A.
- 17.3 Block under Door to help maintain alignment of Door and maintain the 1/8" clearance provided by the shim.
- 17.4 Attach Continuous Gear Hinge to the Door Jamb using the Tek fasteners provided by the gear hinge manufacturer.
NOTE: Take special care when attaching the hinge to the frame. No adjustments can be made once the hinge is attached.
- 17.5 Continue on to 18.0 *Installing Hardware* to complete hardware installation or 19.0 *Final Adjustments to Door* to make final adjustments to the hardware.

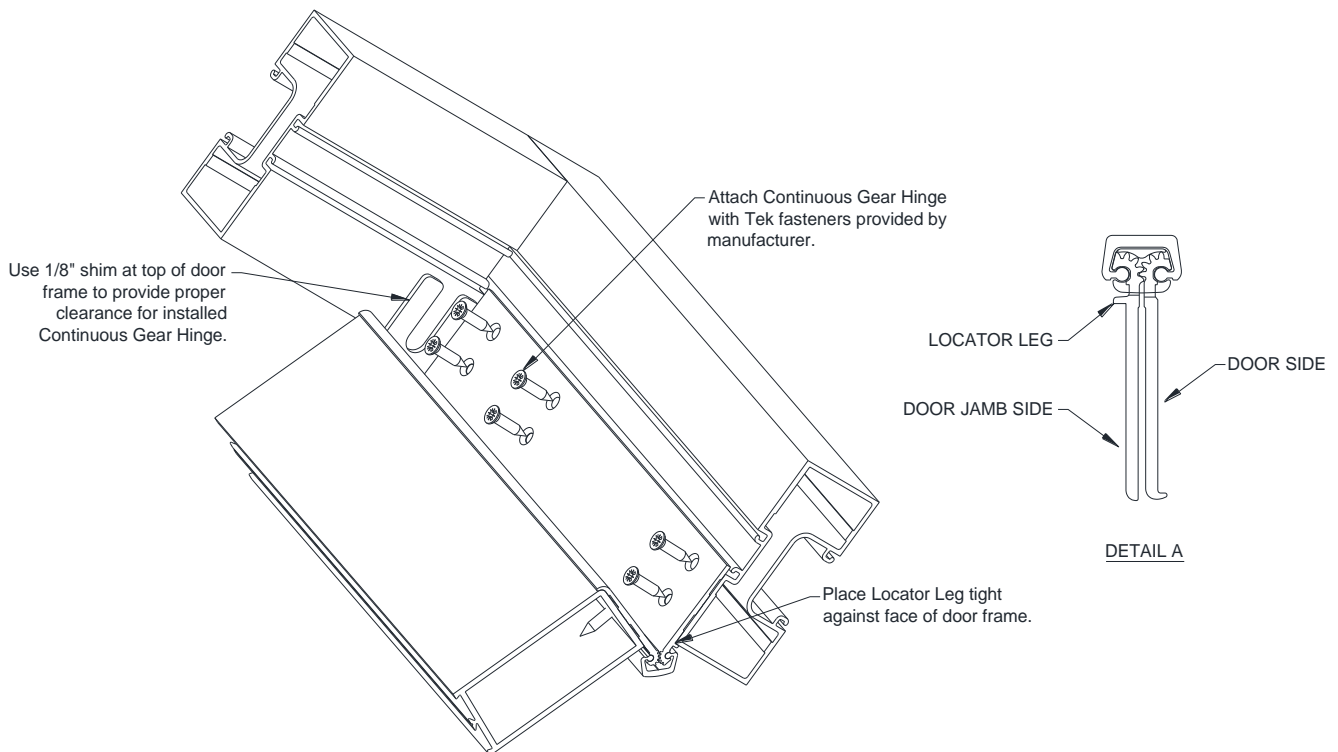

Figure 51: Hanging Door with Continuous Gear Hinge

MSD-375/WSD-500 StormMax® Entrance Installation and Glazing Manual

18.0 Installing Hardware

18.1 Closers

Refer to the instructions included from the manufacturer with the Door Closer.

18.2 Panics

Refer to the instructions included from the manufacturer with the Panic.

18.3 Other Hardware

18.3.1 Cylinder

Doors requiring cylinders have locking cylinders factory installed. If changing the locking cylinder is required, follow all instructions from the manufacturer of the customer-provided cylinder.

18.3.2 Door Pull Handle / Push Bars

14.1.1.1 Holes for Pull Handles and Push Bars are factory drilled in Door.

14.1.1.2 Verify Door Pull kit includes through-bolts and washers. Contact OBE Sales Rep if anything is missing.

14.1.1.3 Place Washers over the Through-Bolts.

14.1.1.4 Align Door Pull with holes in Door on the exterior of Door.

14.1.1.5 Insert Through-Bolts into Door and into Door Pull from interior of Door.

18.3.3 Door Sweep

18.3.3.1 The **D-118** sweep retainer is shipped prefabricated. Cut **D-118** and **D-120** sweep between stops. Maximum distance for attachment holes from edges is 1". If necessary, drill an additional clear hole into the **D-118** 1" from edge and countersink for #8 flat head fastener.

18.3.3.2 Align **D-118** so top edge is located 1-1/8" from bottom edge of door rail, then match drill rail for #8 fasteners.

18.3.3.3 Attach **D-118** to bottom rail with **FS-2** fasteners.

18.3.3.4 Slide **D-120** sweep into slot of **D-118** and stake at both ends to secure. Reference Figure 49.

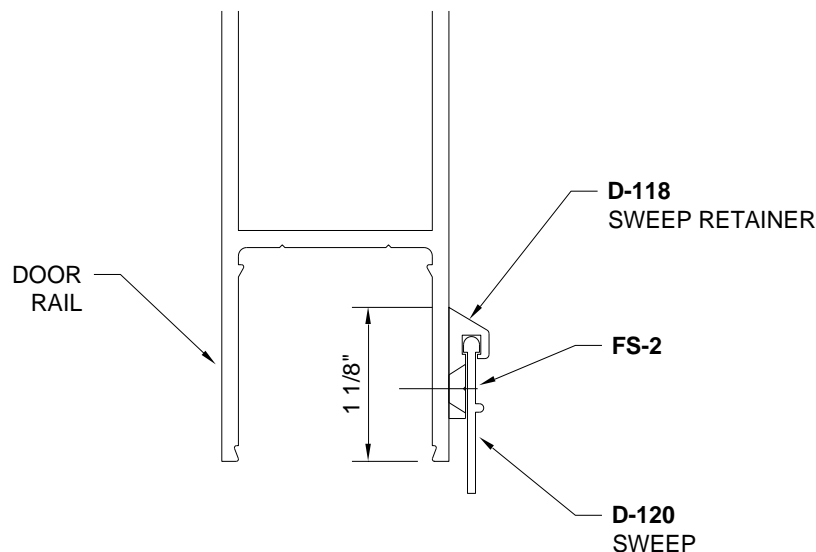

Figure 52: Installing the Door Sweep

MSD-375/WSD-500 StormMax® Entrance Installation and Glazing Manual

Final Adjustments to Door

After installation and hanging, the door needs to be checked and adjusted for proper clearances and functionality.

- 18.4 The top rail of Door should remain at 1/8" spacing below the Door Header. The bottom of Door should remain a consistent 3/16" above Threshold.
- If the gap is too large at the top rail, deglaze the door and verify Door is square before re-applying structural silicone sealant.
 - Offset Pivot doors may be adjusted vertically by removing the slotted set screw at the bottom pivot to access an internal hex head (Allen) adjustment socket. The procedure for this is shown in Figure 50, Detail A.

- 18.5 The hinge-side gap between Door and Door Frame should be as follows:

Butt Hinge/Offset Pivot: 3/32" at both stiles

Continuous Gear Hinge: 5/16" at the hinge stile
3/32" at the lock stile

The corrective action for doors out of compliance will vary by type:



- Butt Hinges may be shimmed out to adjust clearance when there is more than 3/32" at Lock Cylinder side of Door.
 - Offset Pivot Doors may not be adjusted inward or outward, only vertically. Doors out of alignment horizontally will need to be removed completely from the door frame and the pivots must be re-centered and re-installed. This will compromise the stability and strength of the Door Frame.
 - Continuous Gear Hinge Doors out of alignment will need to be removed completely from the door frame and re-installed. This will compromise the stability and strength of the Door Frame.
- 18.6 Door Pairs should have a consistent 1/8" gap between Doors.
- If the gap is not consistent or not 1/8", adjust the screws in the adjustable astragal until a 1/8" gap is attained.

MSD-375/WSD-500 StormMax® Entrance Installation and Glazing Manual



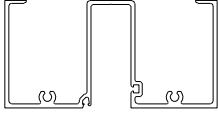
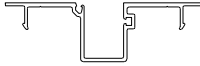
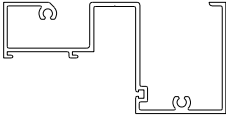
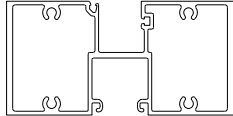

PARTS LIST

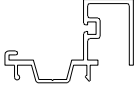
Parts not shown to scale.

FG-5700 StormMax® Framing

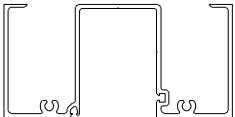
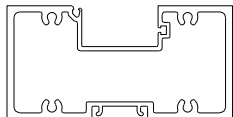
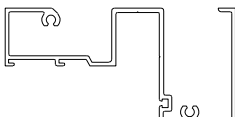

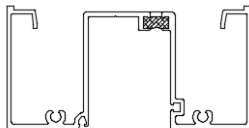



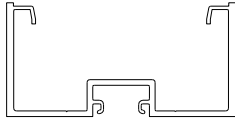
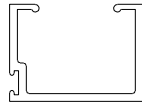

FG-5700 	TRANSOM HEAD	FG-5711 	SIDELITE FILLER
FG-5701 	TRANSOM HEAD	FG-5766 	DOOR HEADER (FOR SURFACE CLOSER)
FG-5710 	GLASS STOP	FG-5198 	TRANSOM SASH

FG-5750 StormMax® and FG-5750T StormMax® Framing

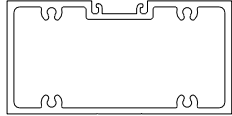
FG-5750 	TRANSOM HEAD	FG-5767 	DOOR HEADER (FOR SURFACE CLOSER)
FG-5751 	TRANSOM HEAD	FG-5181 	TRANSOM SASH
FG-5760 	GLASS STOP	FGT-5770 	THERMAL TRANSOM HEAD (FG-5750T ONLY)
FG-5761 	SIDELITE FILLER	FG-5719 	VINYL FLAT FILLER

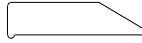
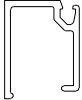
MSD-375/WSD-500 StormMax® Entrance Installation and Glazing Manual

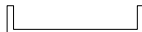
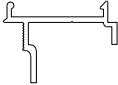
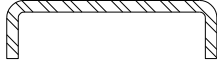
Common Framing Members

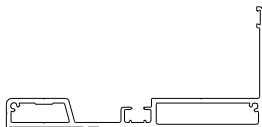
<p>FG-5713</p> 	<p>DOOR JAMB</p>	<p>DS-104</p> 	<p>DOOR STOP (FOR CONCEALED CLOSER DOOR HEADER)</p>
<p>FG-5715</p> 	<p>FLAT FILLER</p>	<p>SC-1</p> 	<p>SPRING CLIP (ATTACHES DS-104 TO FG-5765)</p>
<p>FG-5765</p> 	<p>DOOR HEADER (FOR CONCEALED CLOSER)</p>	<p>TH-57</p> 	<p>THRESHOLD</p>
<p>FG-5223</p> 	<p>DOOR STOP COVER (FOR CONTINUOUS GEAR HINGE)</p>	<p>D134-3</p> 	<p>PANIC STOP (PAIRS ONLY, AS REQ'D BY HARDWARE)</p>
<p>FG-5769</p> 	<p>SASH GLAZING STOP</p>	<p>FG-5716</p> 	<p>ANCHOR SUPPORT AT HEAD (USED W/ FG-5766)</p>
<p>FG-5163</p> 	<p>TYPICAL DOOR STOP</p>	<p>TH-60 / FG5000-FP-19</p> 	<p>THRESHOLD ANCHOR PLATE</p>
<p>FG-5222</p> 	<p>DOOR STOP BASE (FOR CONTINUOUS GEAR HINGE)</p>	<p>FG5000-PP-8</p> 	<p>STEEL REINFORCEMENT</p>
<p>FG-5180</p> 	<p>SUBSILL FOR FG- 5700 OR FG-5750</p>	<p>FG-5712</p> 	<p>SUBSILL FOR FG-5750</p>



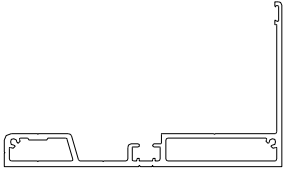
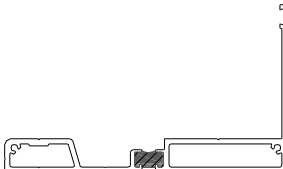
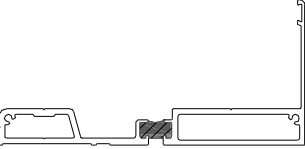

MSD-375/WSD-500 StormMax® Entrance Installation and Glazing Manual

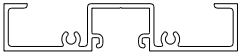
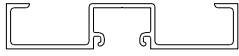
<p>FG-5726</p> 	<p>SUBSILL FOR FG-5750</p>	<p>FGT-5726</p> 	<p>SUBSILL FOR FGT-5750T</p>
<p>FGT-5712</p> 	<p>SUBSILL FOR FGT-5750T</p>		

StormMax® Curtain Wall Subframe Members

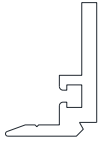
<p>D-231</p> 	<p>CURTAIN WALL HEADER SUBFRAME <i>(FOR SURFACE CLOSER)</i></p>	<p>D-226</p> 	<p>CURTAIN WALL JAMB SUBFRAME</p>
--	---	---	---------------------------------------

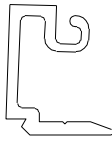
Door and Door Extrusions

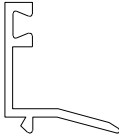
	<p>ASSEMBLED DOOR LEAF</p>	<p>D-152</p> 	<p>TYPICAL WET GLAZING STOP</p>
<p>D-118</p> 	<p>DOOR SWEEP RETAINER</p>	<p>S-83</p> 	<p>TYPICAL GLASS STOP</p>
<p>D-120</p> 	<p>DOOR SWEEP</p>	<p>S-81</p> 	<p>GLASS STOP <i>(FOR 1" DOOR INFILL)</i></p>

Gaskets

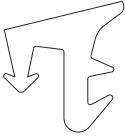
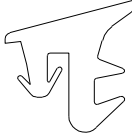

<p>FG-1133</p> 	<p>TYPICAL DOOR GLAZING GASKET</p>	<p>FG-5730</p> 	<p>SIDELITE/TRANSOM FRAMING EXTERIOR GASKET</p>
--	--	---	---

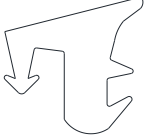
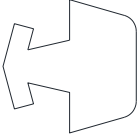
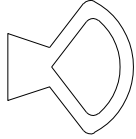

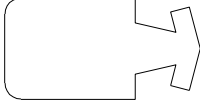
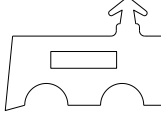
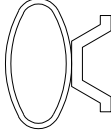

MSD-375/WSD-500 StormMax® Entrance Installation and Glazing Manual

<p>FG-1134</p> 	<p>LIGHT DOOR GLAZING GASKET <i>(PROVIDED FOR USE IF GLASS THICKNESS COMES IN HEAVY)</i></p>
<p>FG-5125</p> 	<p>HEAVY DOOR GLAZING GASKET <i>(PROVIDED FOR USE IF GLASS THICKNESS COMES IN LIGHT)</i></p>
<p>FG-5188</p> 	<p>DOOR WET GLAZE SPACER GASKET</p>
<p>V-28</p> 	<p>DOOR GASKET <i>(FOR 1" INFILL)</i></p>

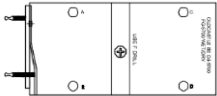
<p>FG-5731</p> 	<p>STOREFRONT FRAMING WET GLAZE SPACER GASKET</p>
<p>FG-5732</p> 	<p>DRY GLAZED FRAMING GASKET <i>(SIDELITE ONLY)</i></p>
<p>D-125</p> 	<p>DOOR WEATHER SEAL GASKET</p>



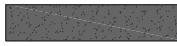

Accessories

<p>D-123</p> 	<p>SETTING BLOCK <i>(FOR 1" DOOR INFILL)</i></p>
<p>HP-17</p> 	<p>SETTING BLOCK <i>(AT FG-5766 TRANSOM DOOR HEADER)</i></p>
<p>FG5000-PP-1</p> 	<p>DOOR SETTING/SIDE BLOCK</p>
<p>DJ-5700</p> 	<p>DRILL JIG FOR FG-5700 FRAMING</p>

<p>HP-92</p> 	<p>SETTING BLOCK <i>(AT FG-5767 TRANSOM DOOR HEADER)</i></p>
<p>FG-5229</p> 	<p>SETTING BLOCK <i>(AT FG-5198 TRANSOM SASH)</i></p>
<p>SM5601</p> 	<p>1/2" X 1/8" BUTYL JOINT SEALANT TAPE</p>
<p>DJ-5750</p> 	<p>DRILL JIG FOR FG-5750 FRAMING</p>

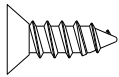
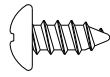
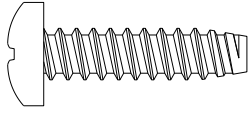
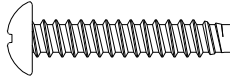
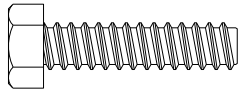
MSD-375/WSD-500 StormMax® Entrance Installation and Glazing Manual

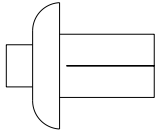
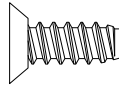
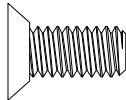
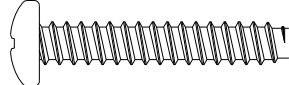
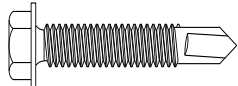
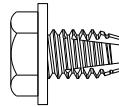
Fasteners

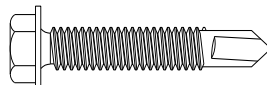
FS-2 	#8 x 1/2" PHILLIPS FLAT HEAD A PT. (ATTACHES D-118 SWEEP RETAINER)	FS-114 	#8 X 3/8" PHILLIPS PAN HEAD A PT. (ATTACHES D-152 GLASS STOP)
FS-6 	#10 x 3/4" PHILLIPS ROUND HEAD B PT. (ATTACHES TRANSOM SASHES)	FS-115 	#10 x 1" PHILLIPS PAN HEAD B PT. (ATTACHES FG-5222 DOOR STOP BASE)
FS-8 	1/4 x 1" HEX HEAD B PT. (TYPICAL FRAME ASSEMBLY FASTENER)	FS-201 	#10 x 2" PHILLIPS FLAT HEAD A PT. (ATTACHES DS-104 DOOR STOP, PAIRS ONLY)
FS-15 	3/16" X 1/4" DRIVE RIVET (ATTACHES SC-1 SPRING CLIP)	FS-235 	1/4"-20 X 5/8" PHILLIPS FLAT HEAD (ATTACHES D134-3 PANIC STOP)
FS-22 	#12-24 X 1/2" PHILLIPS FLAT HEAD UNDERCUT MACHINE SCREW (ATTACHES BUTT HINGES TO BACKUP PLATES)	FS-258 	#12 X 1-1/4" PHILLIPS PAN HEAD B PT. (ATTACHES FG-5222 TO CURTAIN WALL SUBFRAME)
FS-322 	#12-14 x 1" HEX WASHER HEAD DRILL FLEX (ATTACHES CURTAIN WALL POCKET FILLERS TO MULLIONS)	FS-354 	#10-24 X 3/8" HEX WASHER HEAD TYPE F (ATTACHES ALUM. & STEEL REINFORCEMENT)
FS-57 	#8 x 3/8" PHILLIPS FLAT HEAD UNDERCUT B PT. (ATTACHES FG-5223 DOOR STOP COVER)	FS-325 	#12-24 x 1-11/32" HEX WASHER HEAD DRILL FLEX (ATTACHES SUBFRAME TO MULLION (Reliance))