

**FRONT**

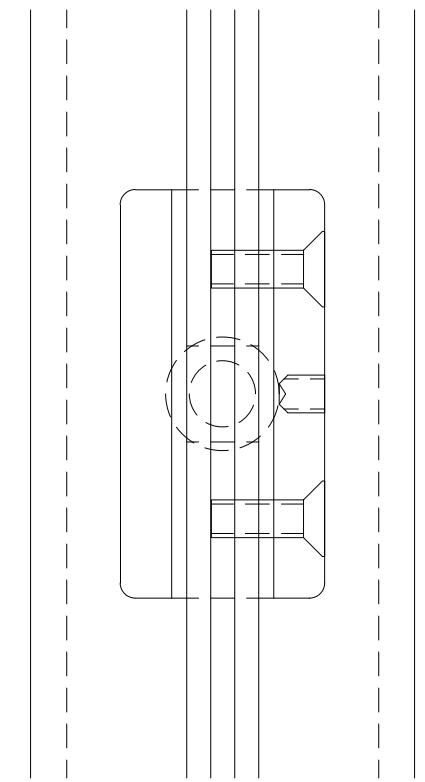

**SIDE**

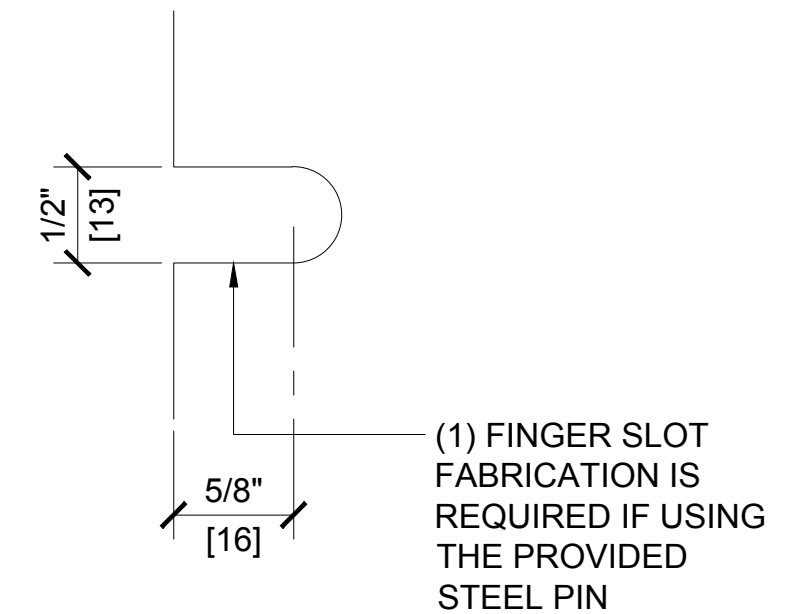

**GLASS PREP**

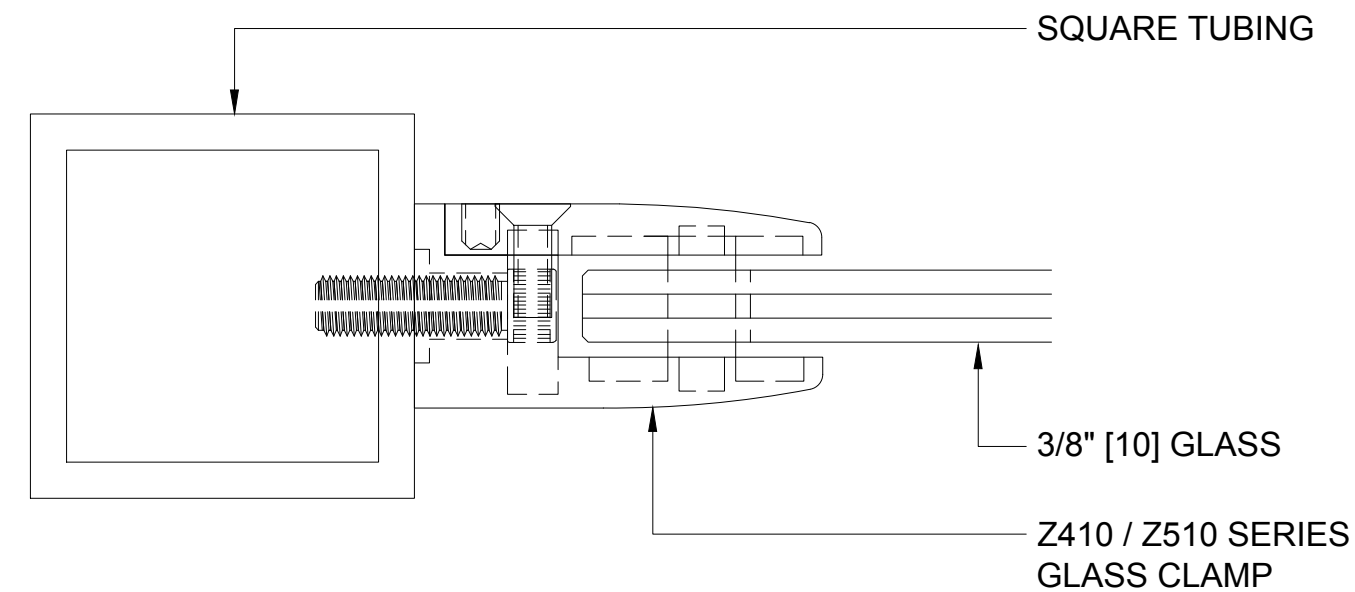

**TOP**

PART #	FINISH
Z410BR	BRASS
Z410CH	CHROME
Z410SC	SATIN CHROME
Z410BN	BRUSHED NICKEL
Z410GP	GOLD PLATED
Z410W	WHITE
Z510BS	BRUSHED STAINLESS
Z510PS	POLISHED STAINLESS

**CRL ALUMINUM**  
 C.R. LAURENCE CO. ARCHITECTURAL PRODUCTS  
 2503 E. Vernon Avenue, Los Angeles, C.A 90058-1897  
 PH (800)-421-6144 FX: 800-587-7501 www.crlaurence.com

DESCRIPTION: **Z410 & Z510 SERIES Z-CLAMPS**

DATE: 5/12/16  
 SCALE: 1'-0"=1'-0"  
 DRAWN BY: AAD