

USE OF GASKETS

FOR 1/4" (6mm) GLASS: USE ONE THICK GASKET ON EACH SIDE
 FOR 5/16" (8mm) GLASS: USE ONE THIN GASKET ON EACH SIDE

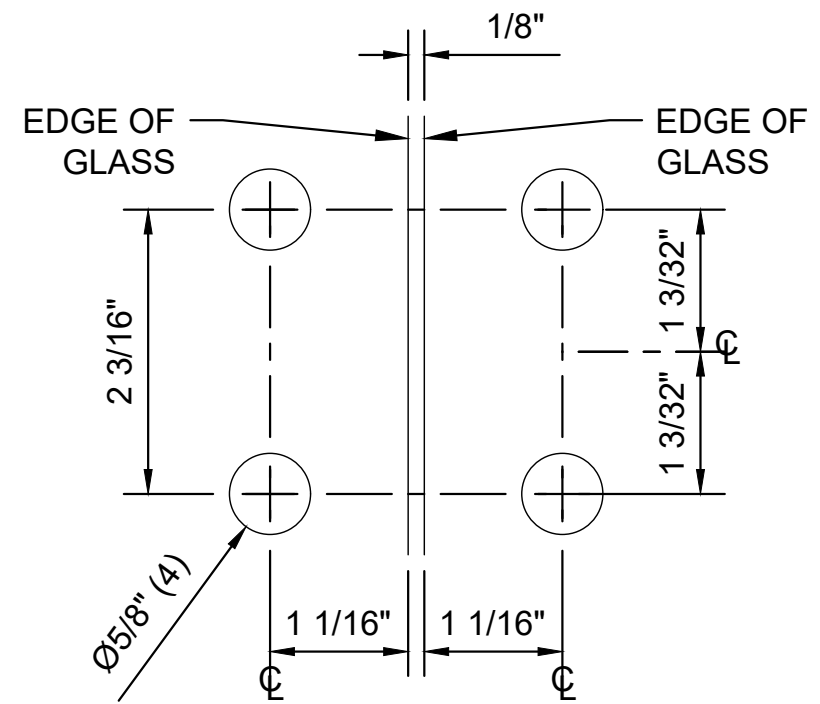

GLASS FABRICATION TEMPLATE

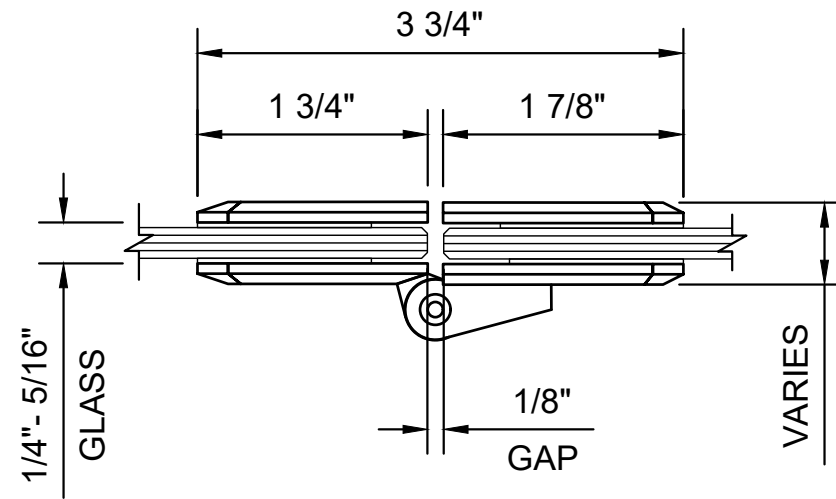
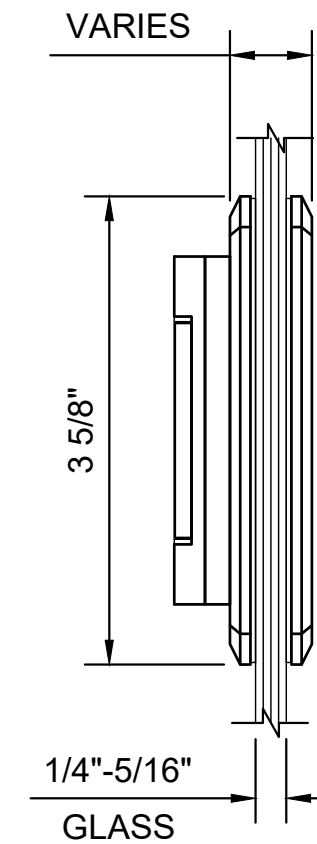
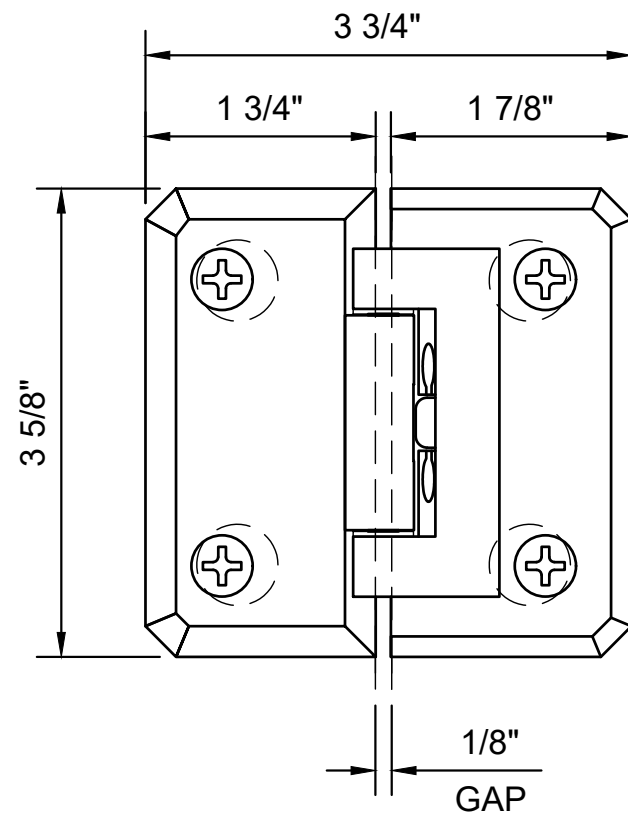

CATALOG NUMBER	FINISH
M0N181CH	POLISHED CHROME
M0N181BN	BRUSHED NICKEL
M0N181GP	GOLD PLATE
M0N181W	WHITE
M0N181WC	WHITE W/ CHROME ACCENT

M0N181XX - CRL MONACO SERIES 180 DEGREE GLASS TO GLASS HINGE

DATE: 3/1/19
 SCALE: 6"=1'-0"
 DRAWN BY: VM

DESCRIPTION: CRL MONACO SERIES HINGE
 CTS
 MON181 180° GLASS TO GLASS
 DOOR SWINGS 180° OUT ONLY
 www.crlaurence.com

C.R. LAURENCE CO. ARCHITECTURAL PRODUCTS
 2503 E. Vernon Avenue, Los Angeles, CA 90058-1897
 PH (800)-421-6144 FX: 800-587-7501 www.crlaurence.com

