

USE OF GASKETS

FOR 3/8" (10mm) GLASS: USE ONE THICK GASKET ON EACH SIDE  
 FOR 1/2" (12mm) GLASS: USE ONE THIN GASKET ON EACH SIDE

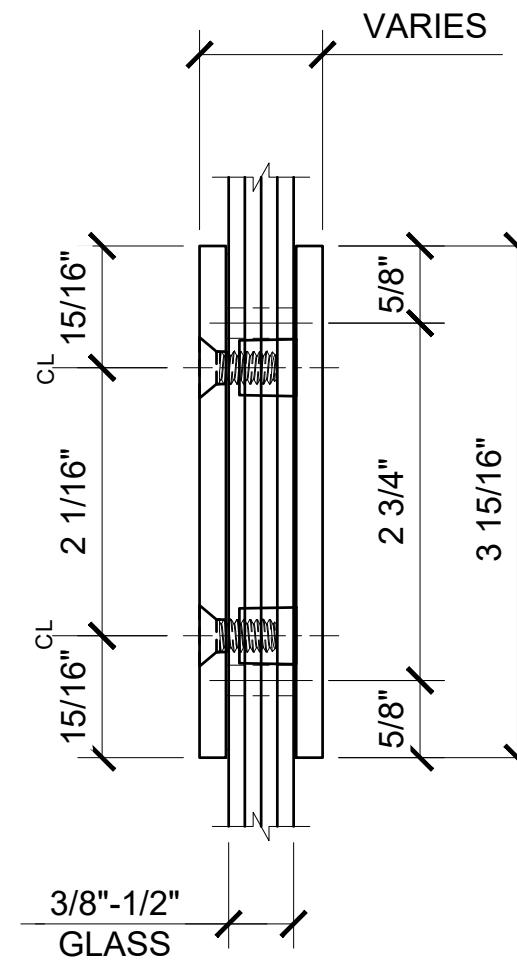
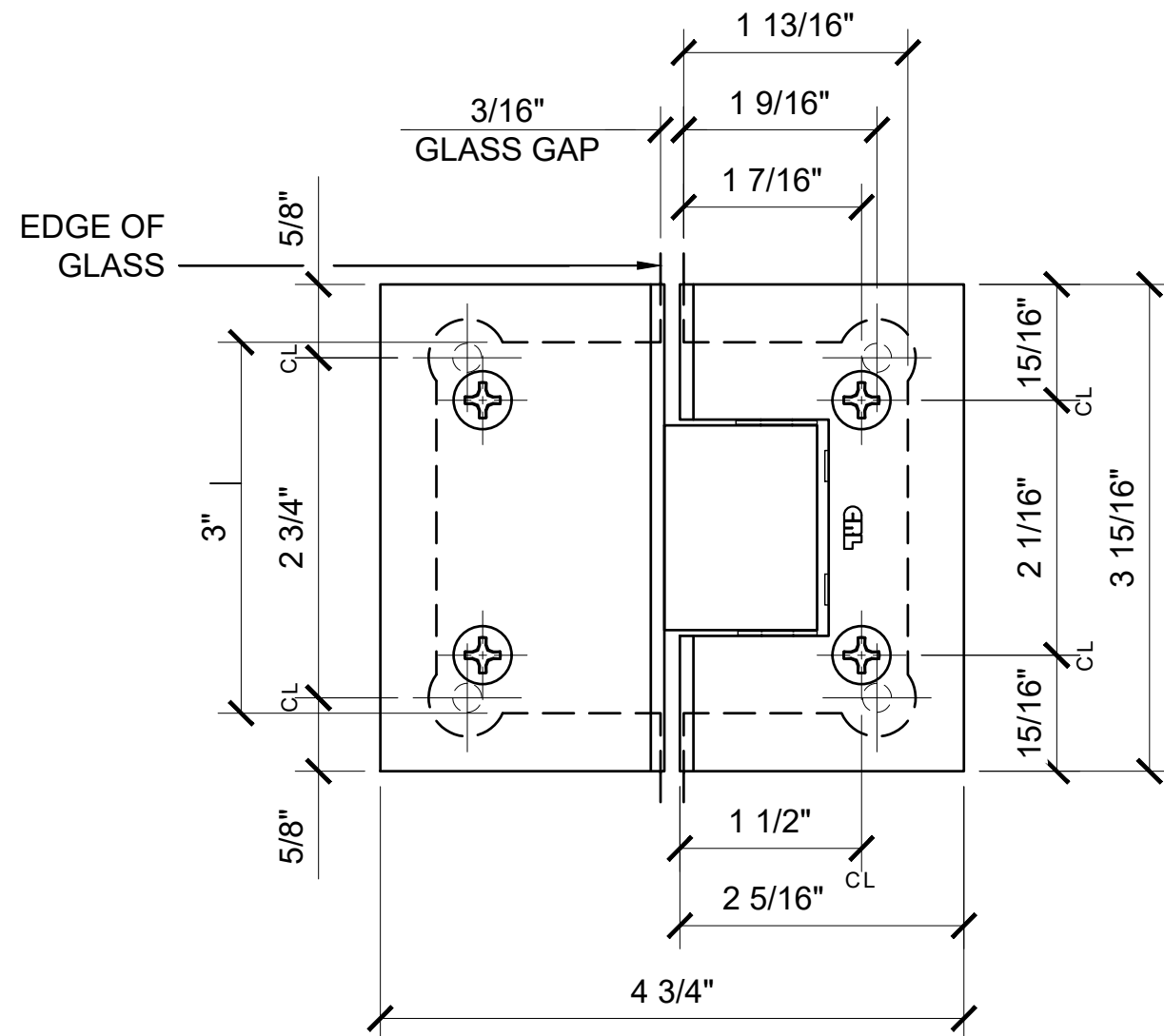
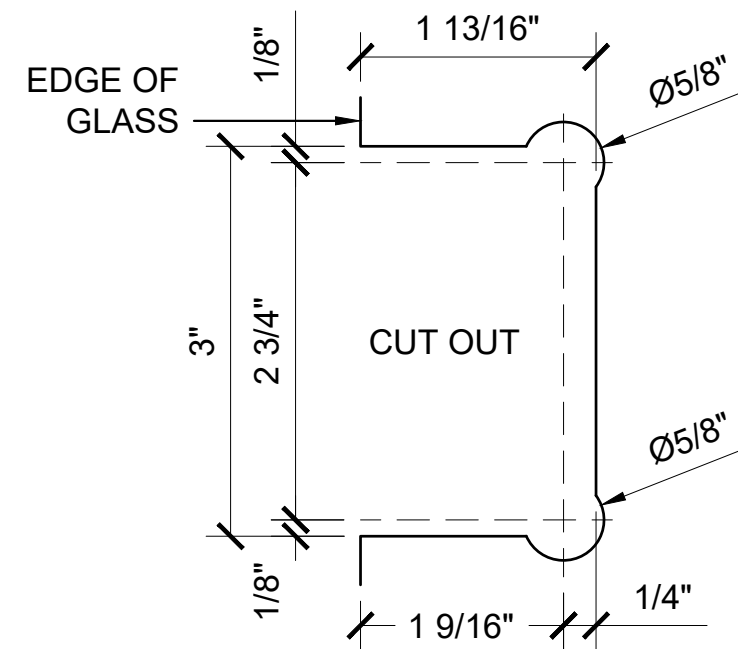
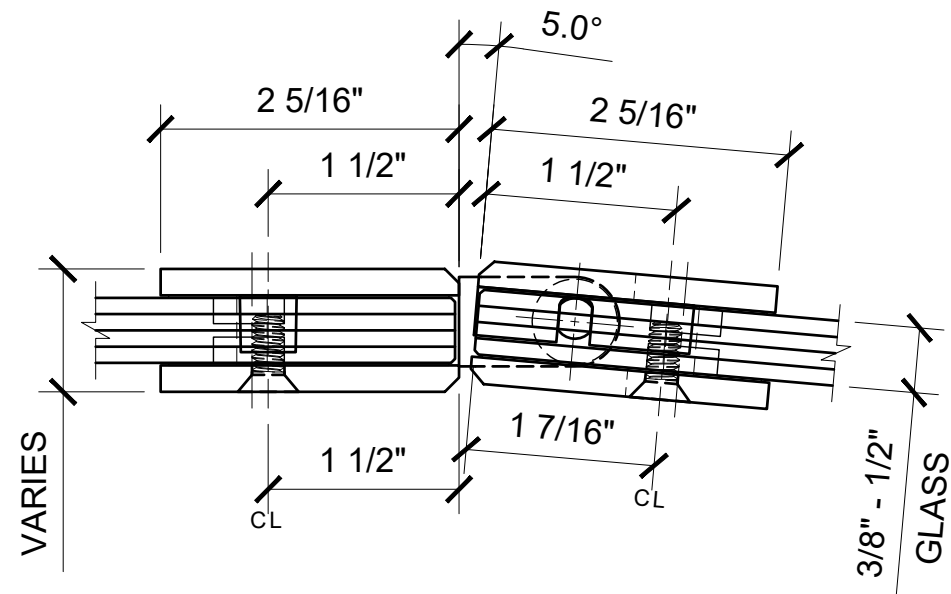

V1E580XX - CRL VIENNA SERIES 5 DEGREE GLASS TO GLASS HINGE

DATE: 11/20/17  
 SCALE: 6"=1'-0"  
 DRAWN BY: VM

DESCRIPTION: CRL V1E580  
 CTS  
 VIENNA SERIES 5 DEGREE  
 GLASS TO GLASS HINGE

C.R. LAURENCE CO. ARCHITECTURAL PRODUCTS  
 2503 E. Vernon Avenue, Los Angeles, CA 90058-1897  
 PH (800)-421-6144 FX: 800-587-7501 www.crlaurence.com

