

DETAIL OF INSIDE FACE OF PIVOT SIDE JAMB FOR ATTACHMENT OF HEAD CHANNEL.

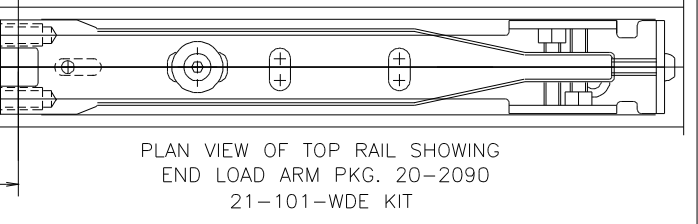

DIMENSIONAL TOLERANCES UNLESS OTHERWISE SPECIFIED DECIMAL DIMENSIONS .XX ± .010 DECIMAL DIMENSIONS .XXX ± .005 ANGULAR ± 1/2° FRACTIONAL ± 1/64		APPROVALS APPROVED CHECKED DRAWN R.M. 11.11.03	DATE SCALE FULL
FILE NO. 10-839 NEXT ASSY. 21-101-WDE-XX QTY. USED 1	MATERIAL FINISH HEAT TREAT	TITLE INST. INSTR. WOOD x ALUM. FRAME	SHEET 1 OF SHEETS DWG. NO. 10-839 REV. B

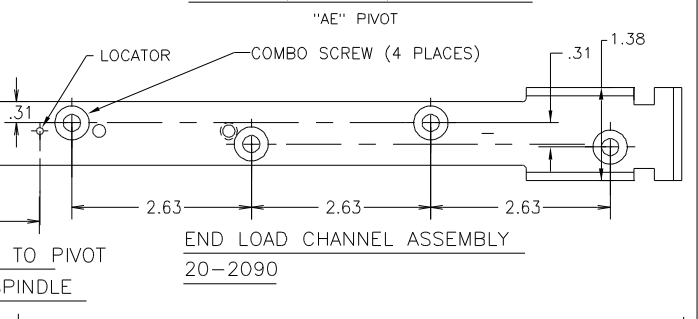
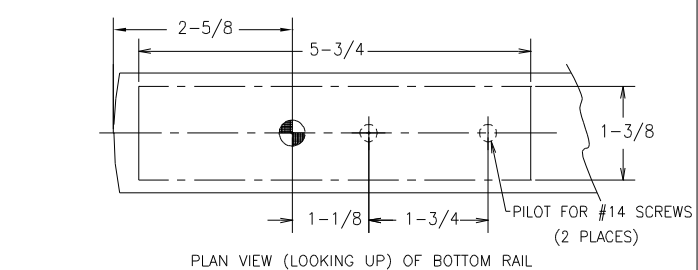
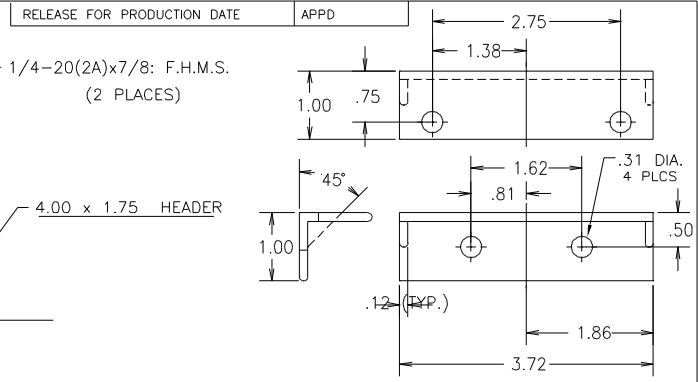
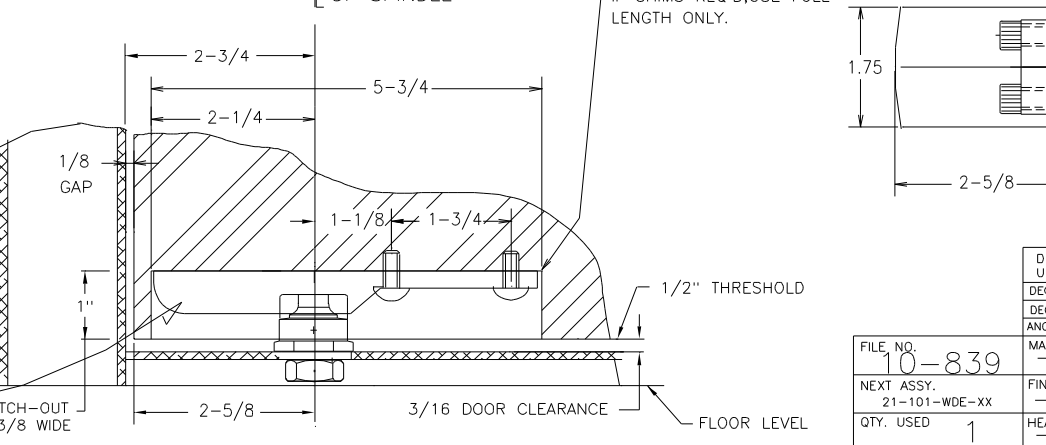
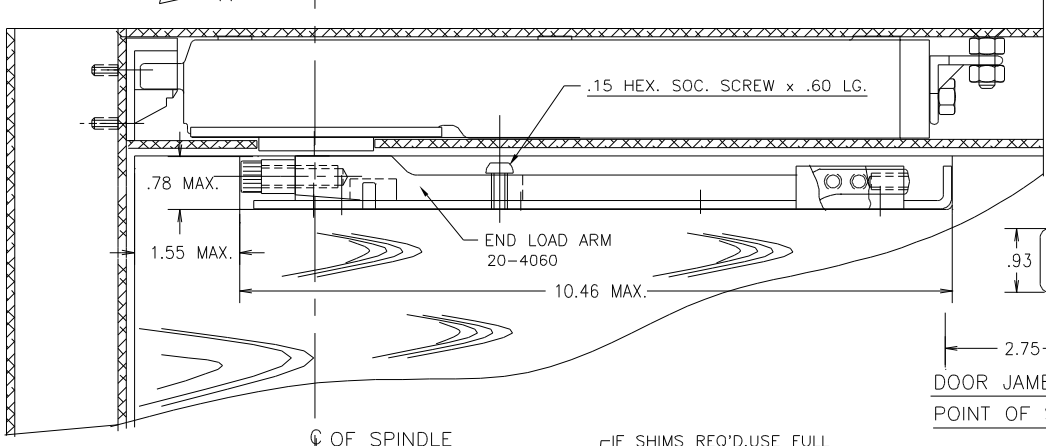
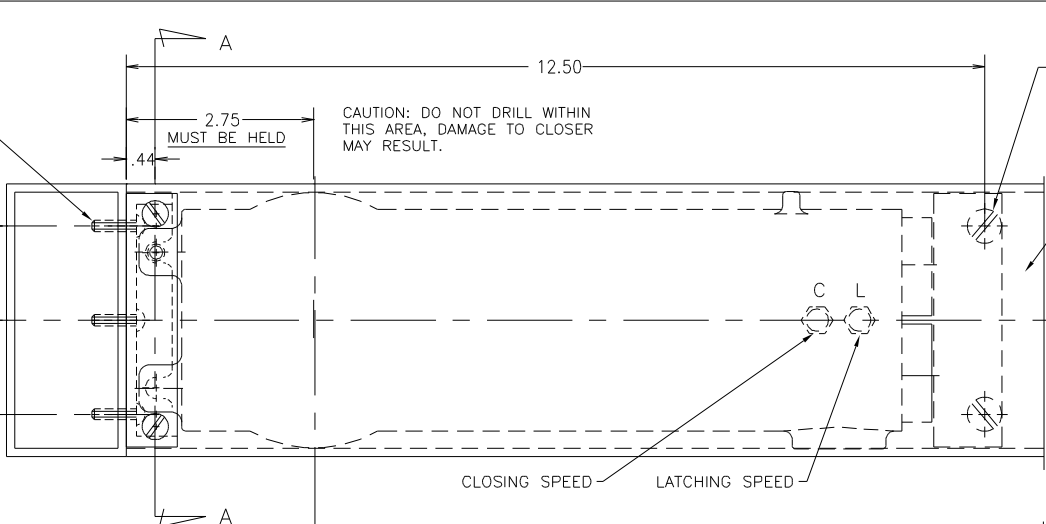
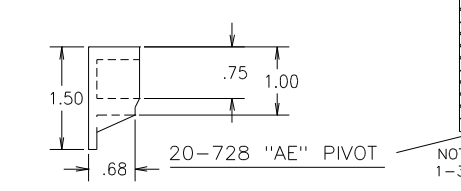
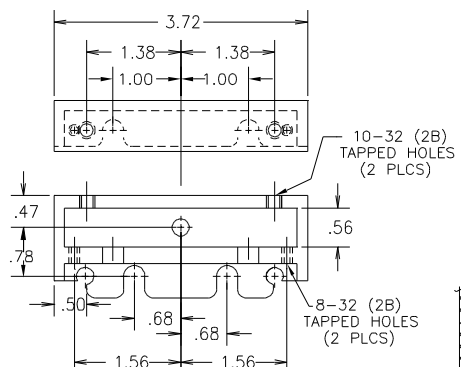
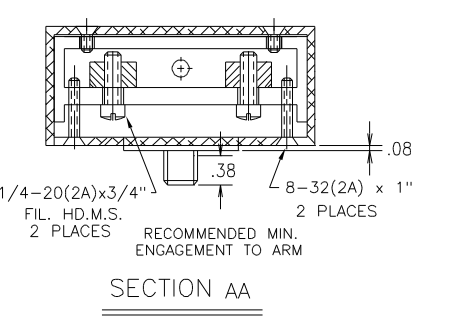
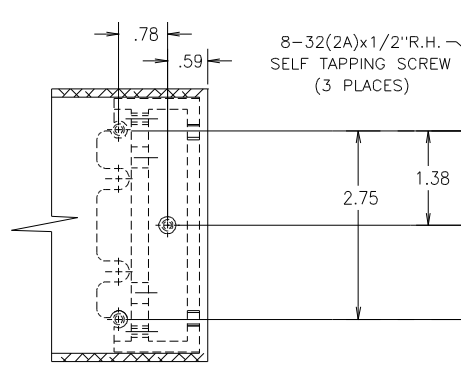

CAUTION: DO NOT DRILL WITHIN THIS AREA, DAMAGE TO CLOSER MAY RESULT.

IF SHIMS REQ'D. USE FULL LENGTH ONLY.