

INSTALLATION INSTRUCTIONS

CRL JACKSON 1275 SURFACE VERTICAL ROD PANIC EXIT DEVICE



Phone: (800) 421-6144 • Fax: (866) 921-0531
crlaurence.com • usalum.com • crl-arch.com

ORDER OF ASSEMBLY AND INSTALLATION

TOOLS REQUIRED 02

PARTS IDENTIFICATION..... 03 - 04

DOOR PREPARATION 05 - 08

 LAYOUT SELECTION 06 - 08

 1275 EXIT DEVICE INSTALLATION 06 - 07

 1275 EXIT DEVICE WITH LOCK CYLINDER AND EXTERIOR TRIM 08

DOOR HARDWARE INSTALLATION 09 - 15

 INSTALL MORTISE CYLINDER LOCK AND EXTERIOR TRIM (OPTIONAL)..... 09

 INSTALL UPPER AND BOTTOM LATCH BRACKET ASSEMBLIES..... 10

 INSTALL 1275 EXIT DEVICE 11

 ROD LINKAGE ADJUSTMENTS..... 12

 CONNECTION OF LINKAGE RODS TO 1275 EXIT DEVICE..... 13

 OPERATIONS CHECK AND DOGGING INSTRUCTIONS 14

 INSTALL END CAPS AND COVER ASSEMBLIES 15

FRAME PREPARATION AND STRIKE INSTALLATION 16 - 17



PACKAGED PARTS AVAILABLE..... 18

TOOLS REQUIRED

- | | |
|--|---------------------------------|
| Drill bits: 1/4", 9/32", 7/32", 3/8", 11/16", 7/8", 1-1/4" | Standard screwdriver |
| Taps: 1/4-20, 10-32, 8-32 | Framing square/straight edge |
| Tape measure | 1" Masking tape |
| Saw horses | Center punch |
| Drill | Flat Metal File |
| Phillips #2 screwdriver | Round Metal File |
| | Jigsaw with metal cutting blade |

NOTE: Any modifications, other than those specified in this document, could result in this product's failure to meet UL safety ratings and void the manufacturer's warranties.

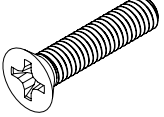
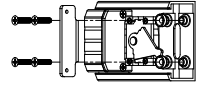
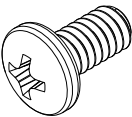
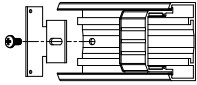
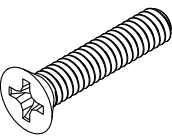
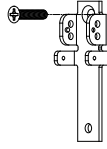
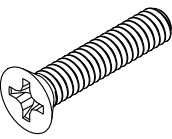
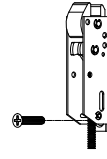
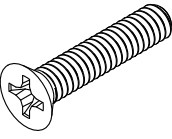
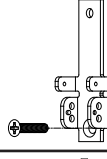
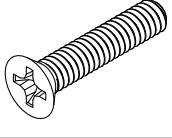
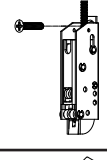
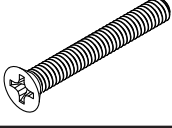
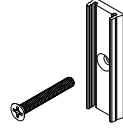
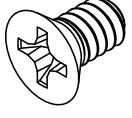
PARTS IDENTIFICATION

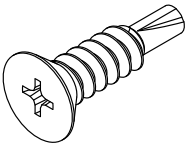
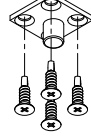
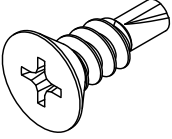
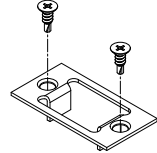
FASTENERS AND PARTS LIST					
CALL OUT	QTY.	FASTENER	FASTENER DESCRIPTION	PART	USED WITH PART NUMBER
(A)	4		10-32 x 7/8" FHMS		302652 Base End Cap Assembly
(B)	1		1/4"-20 x 1/2" PHMS		302652 Base End Cap Assembly
(C)	1		1/4"-20 x 1-1/4" FHMS		Upper Latch Bracket Assembly Included in 302408
(D)	1		1/4"-20 x 1-1/4" FHMS		3028477 Upper Rod and Latch Assembly
(E)	1		1/4"-20 x 1-1/4" FHMS		Bottom Latch Bracket Assembly Included in 302408
(F)	1		1/4"-20 x 1-1/4" FHMS		302854 Bottom Rod and Latch Assembly
(G)	10		8-32 x 1-1/4" FHMS		3028527 and 302856 Upper and Bottom Rod Cover Base Assembly
(H)	4		6-32 x 1/4" FHMS		302841 Upper and Bottom Latch Cover Assembly
(I)	2		10-16 x 3/4" FHDS		(302113 Set) Upper Strike Assembly
(J)	2		8-18 x 1/2" FHDS		(302113 Set) Bottom Strike Assembly

CRL JACKSON PANIC EXIT DEVICE - 1275 SURFACE VERTICAL ROD

PARTS IDENTIFICATION

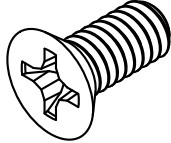
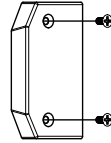
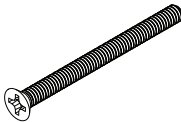
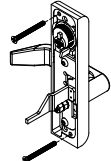
FASTENERS AND PARTS LIST					
CALL OUT	QTY.	FASTENER	FASTENER DESCRIPTION	PART	USED WITH PART NUMBER
(K)	4		8-32 x 3/8" FHMS		302652 Base End Cap Assembly
(L)	2		10-32 x 2-1/8" FHMS		Optional 7500LV02628 and 7500LVDT01628 Exterior Trim With Lever Assembly

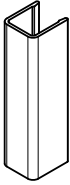
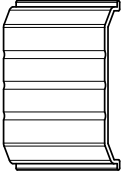
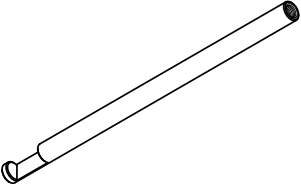
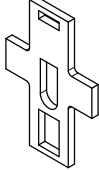
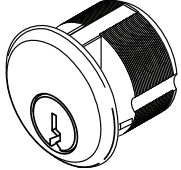
PARTS LIST			
CALL OUT	PART	PART NO.	DESCRIPTION
(M)		3028527 and 302856	Upper and Bottom Rod Covers
(N)		302674 and 30267448	Base Cover Plates
(O)		N/A	Rod Adjusters Included in 302741ASM Assembly Package
(P)		302741	Cruciform Rod Activation Included in 302741ASM Assembly Package
(Q)		DL2170	Optional 1" Single Mortise Cylinder

DOOR PREPARATION

REMOVE DOOR AND PREPARE PER ATTACHED LAYOUT DRAWING 10-1082-1

1. Place the door horizontally on the work stands, interior side up.
2. Mark the stile centerlines 1" from the outside edge of the stile. (Fig. 1)
3. Mark the corresponding layouts on to the stile using the vertical centerlines at the specified height. (Fig. 2)

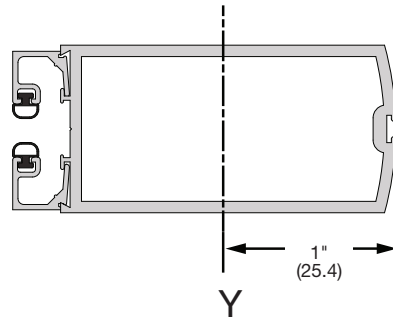

FIG. 1

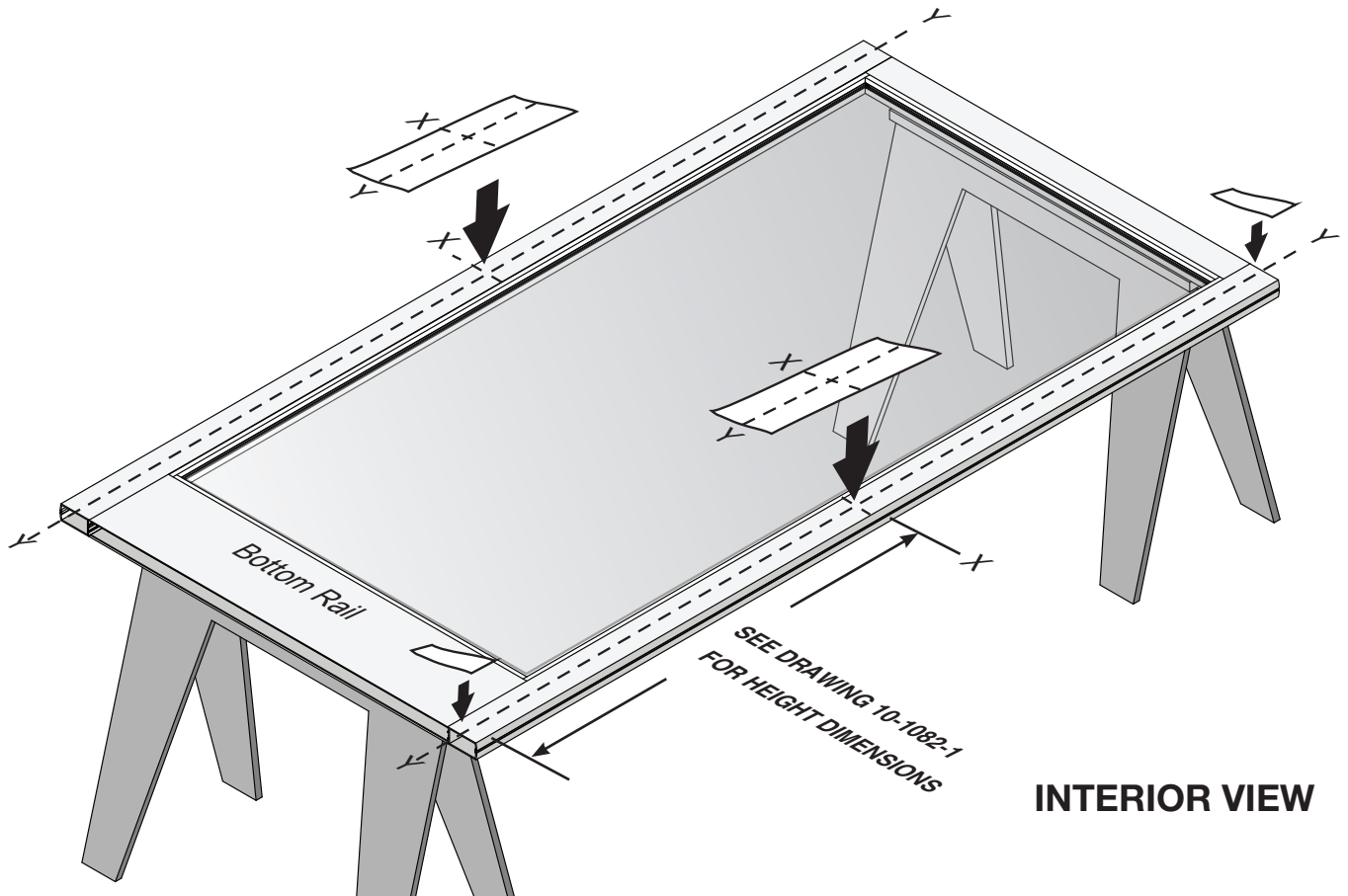

FIG. 2

NOT TO SCALE

DOOR PREPARATION – LAYOUT SELECTION

1275 EXIT DEVICE INSTALLATION - ACTIVE STILE

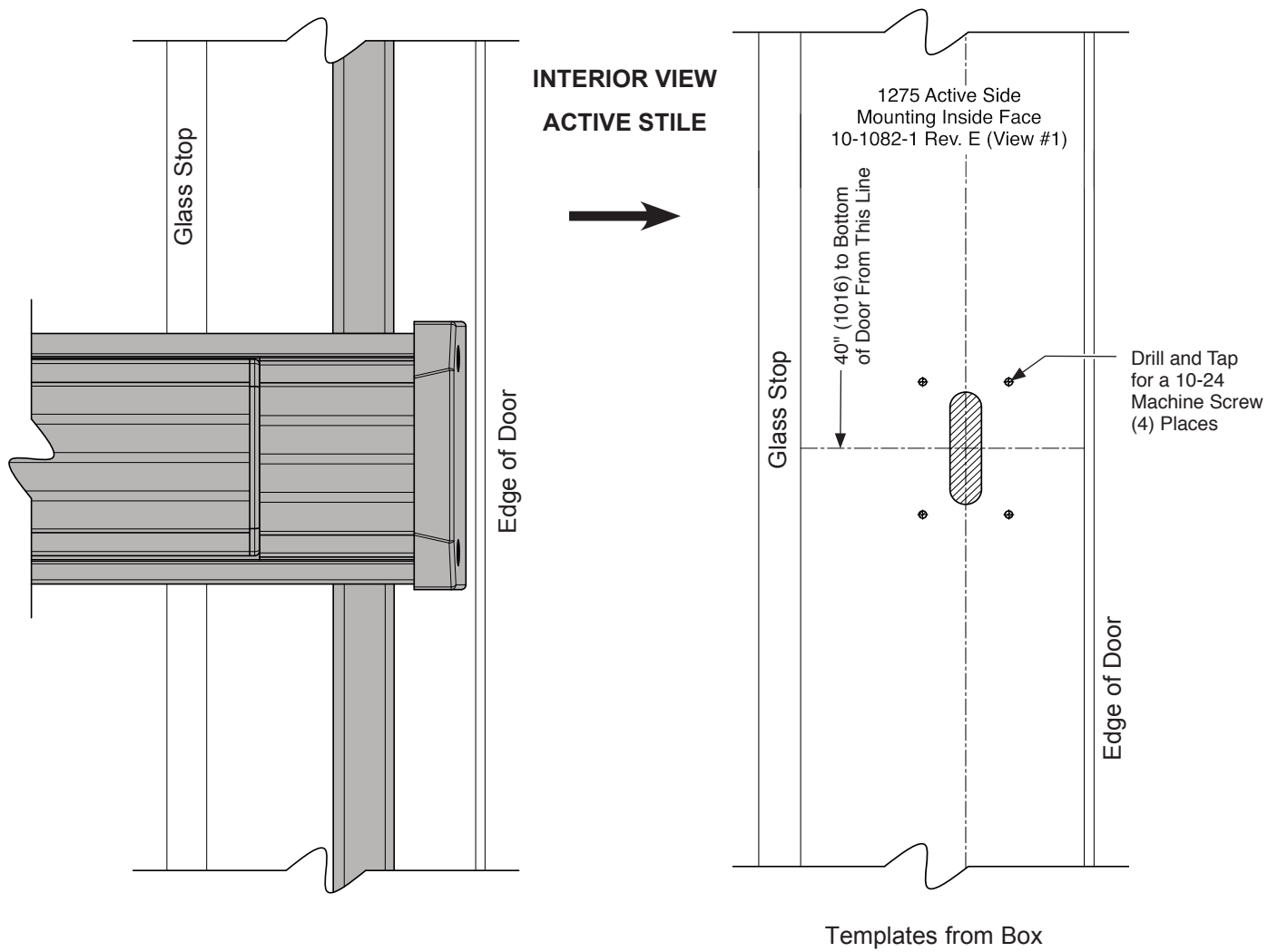

FIG. 3

NOT TO SCALE

DOOR PREPARATION – LAYOUT SELECTION

1275 EXIT DEVICE INSTALLATION - INACTIVE STILE

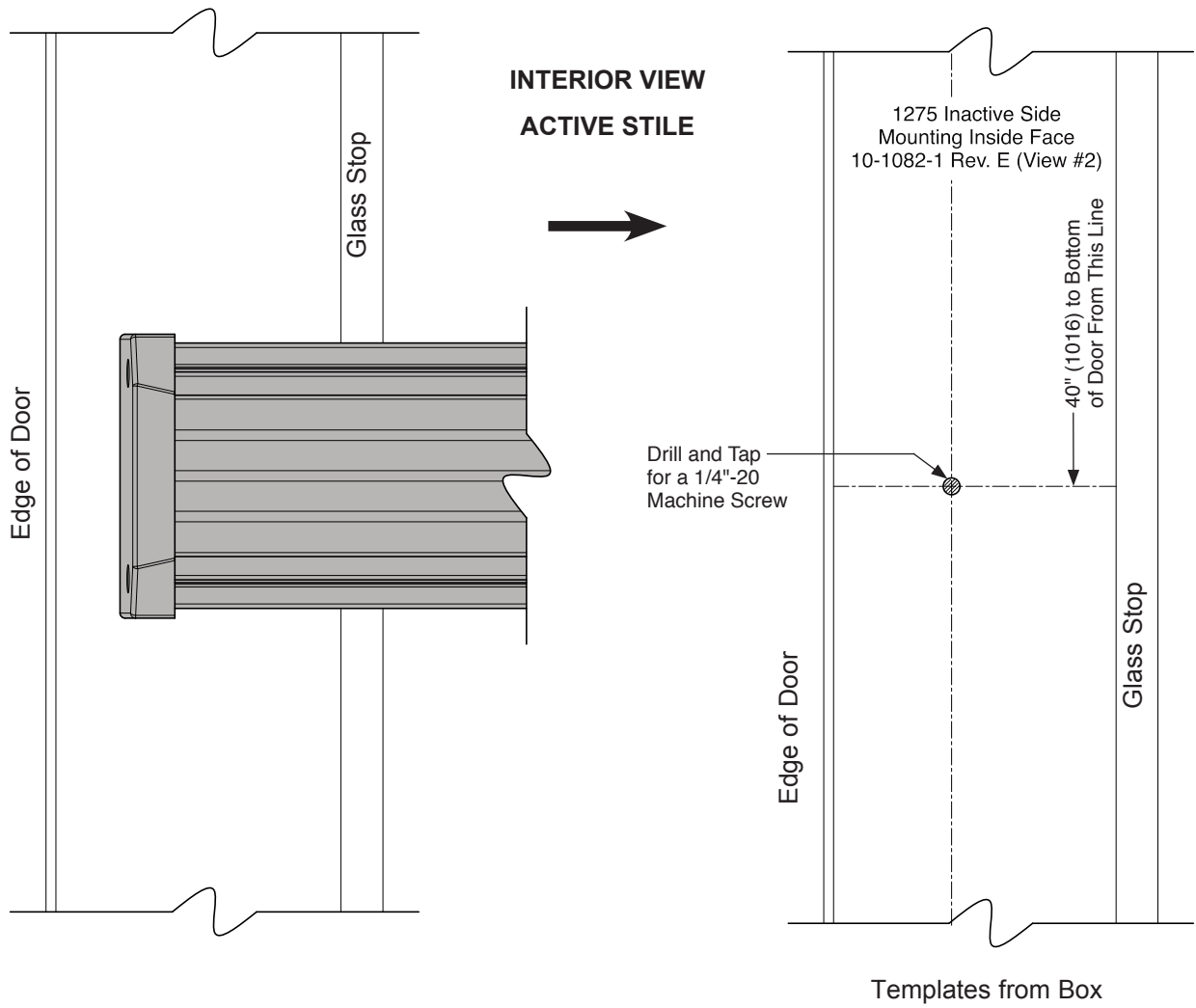

FIG. 4

NOT TO SCALE

DOOR PREPARATION – LAYOUT SELECTION

1275 EXIT DEVICE INSTALLATION WITH OPTIONAL EXTERIOR TRIM AND MORTISE CYLINDER LOCK

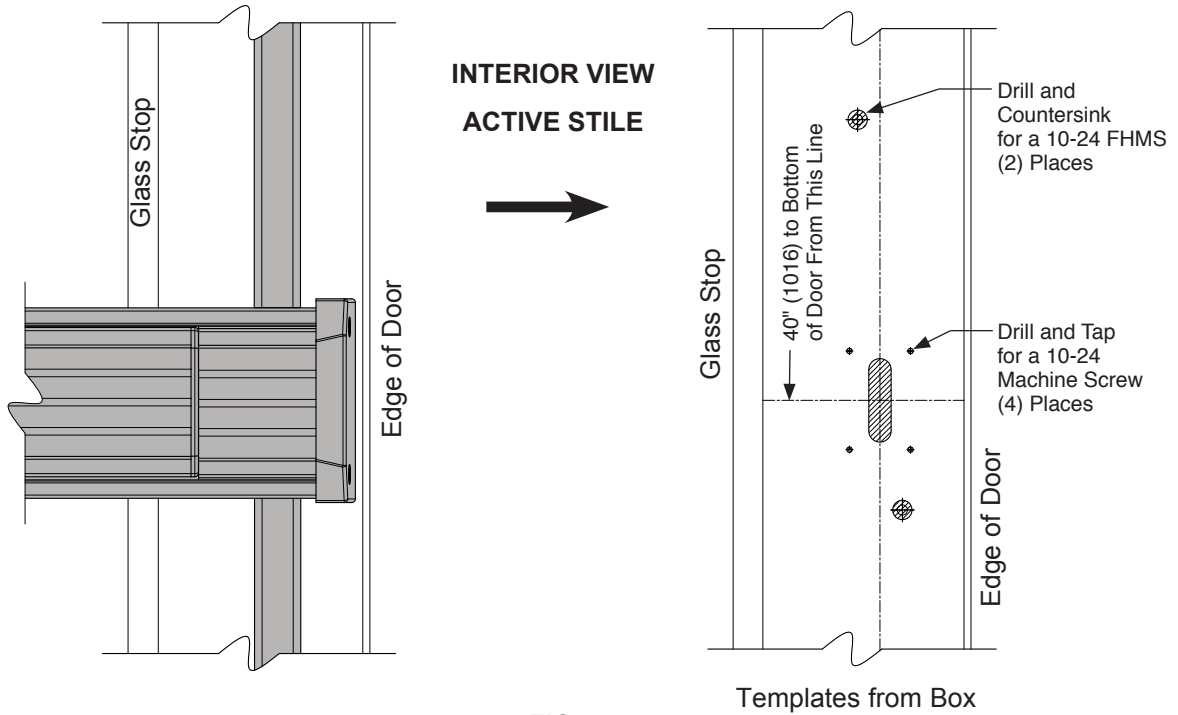

FIG. 5

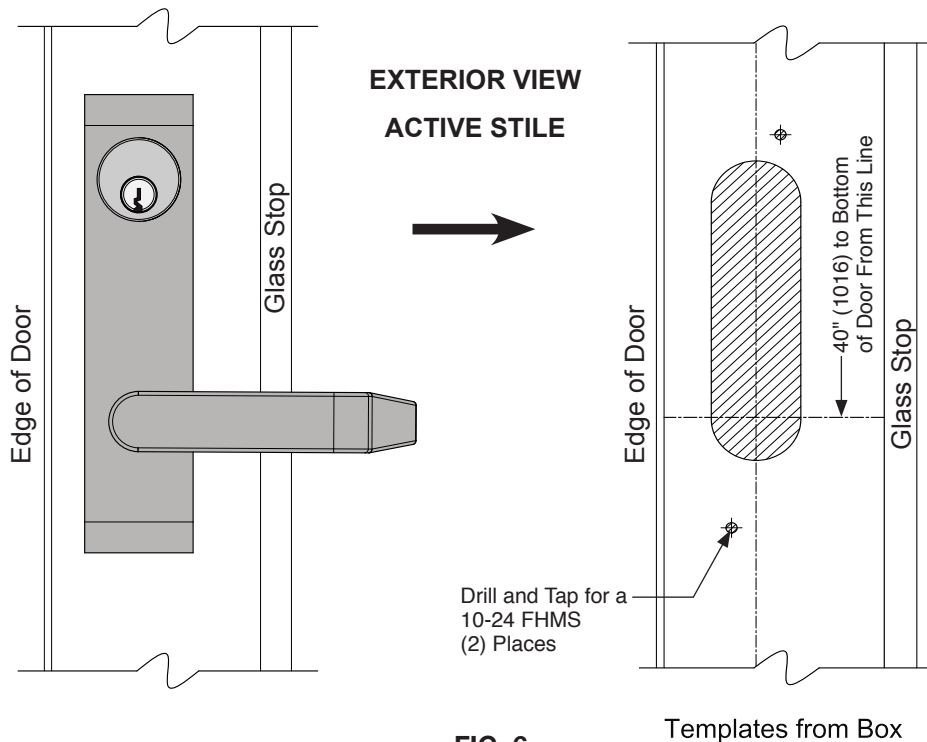

FIG. 6

NOT TO SCALE

DOOR HARDWARE INSTALLATION

INSTALL OPTIONAL MORTISE CYLINDER LOCK AND EXTERIOR TRIM

NOTE: Exterior trim must be installed before attaching exit device.

1. Attach the exterior trim to the active stile with (2) #10 x 2-1/8" FHMS (L)

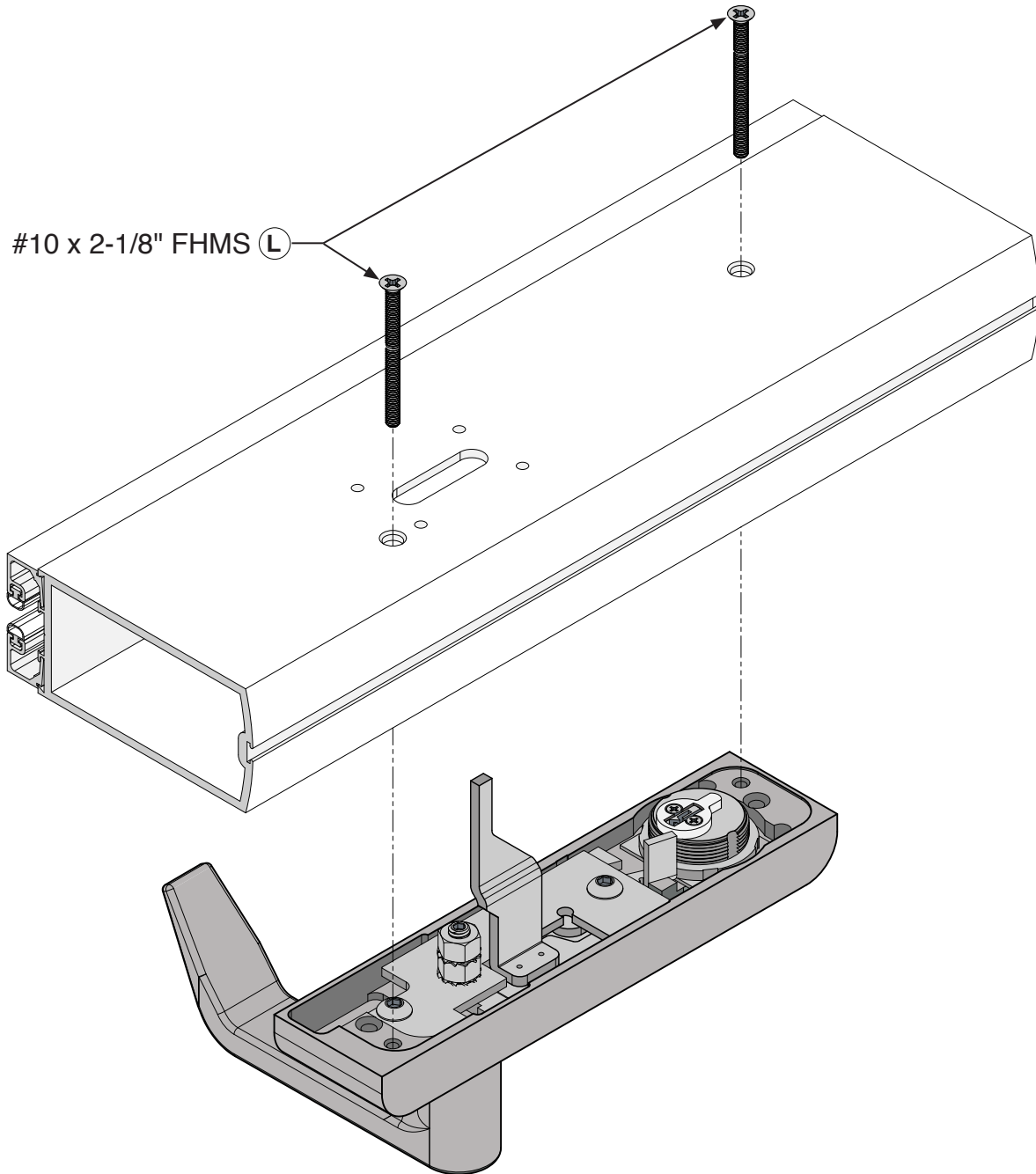

FIG. 7

NOT TO SCALE

DOOR HARDWARE INSTALLATION (CONTINUED)

INSTALL UPPER AND BOTTOM LATCH BRACKET ASSEMBLIES

1. Attach the upper and bottom latch bracket assemblies **302408** to the prepped active door stile using (2) 1/4"-20 x 1-1/4" FHMS **(C)(E)**
2. Attach the upper and bottom rod cover base assemblies **3028527** and **302856** to the prepped active door stile using (10) 8-32 x 1-1/4" FHMS **(G)**
3. Attach the upper and bottom rod latch assemblies **3027854** and **3028477** to the latch brackets using (2) 1/4"-20 x 1-1/4" FHMS **(D)(F)** and the bracket pins provided. It is normal for the Latch assemblies to have some play. Secure the pins with the crescent clips provided.
4. Attach the upper and bottom rod adjusters **302741** **(O)** onto the ends of the all-thread linkage rods approximately 1/4".

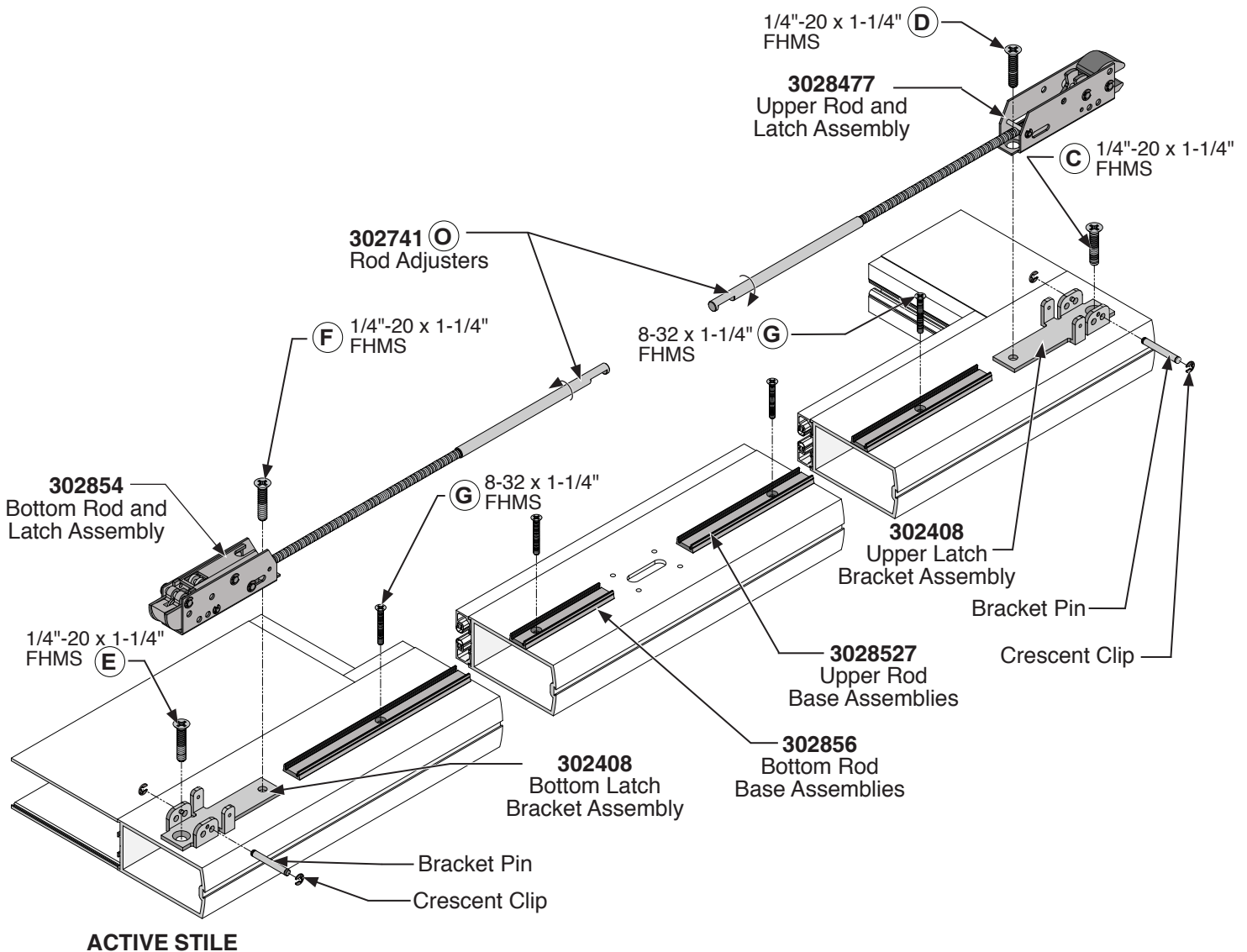

FIG. 8

NOT TO SCALE

DOOR HARDWARE INSTALLATION (CONTINUED)

INSTALL 1275 EXIT DEVICE

1. Attach the panic exit device to the active stile with (2) 10-32 x 7/8" FHMS (A) and (1) 1/4"-20 x 1/2" PHMS (B) through the end cap bracket on the inactive stile.
2. Insert the upper and bottom rod adjusters 302741 (C) into the linkage access holes.

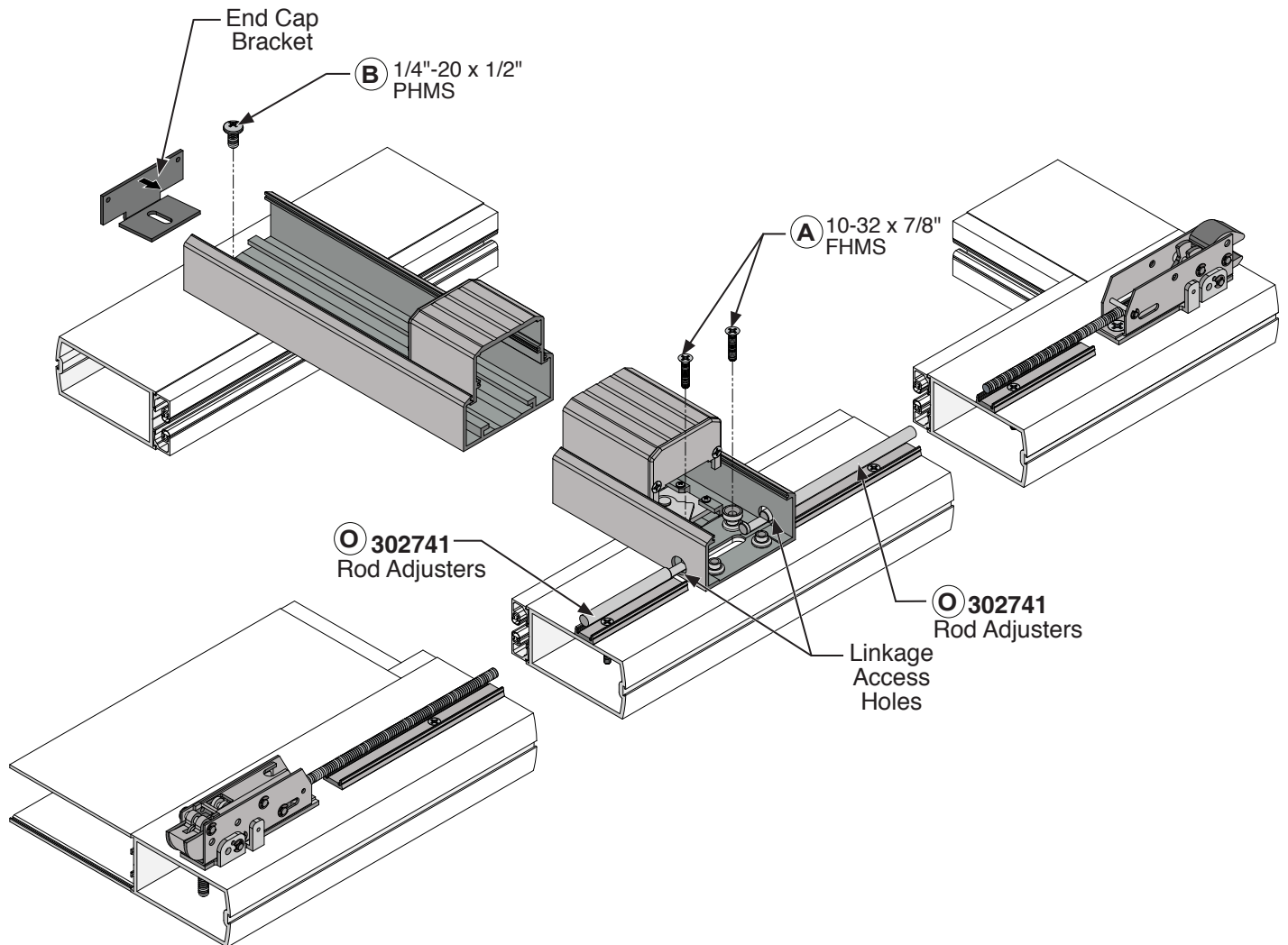

FIG. 9

NOT TO SCALE

DOOR HARDWARE INSTALLATION (CONTINUED)

ROD LINKAGE ADJUSTMENTS

UPPER ROD:

1. The top latch must be in the open position. (Fig. 10)
2. Turn the adjuster rod so that the end is aligned with the top line marking, just under the words "TOP LATCH" and the rod cut out is facing towards you. (Fig.12)

BOTTOM ROD:

1. The bottom latch must be in the closed position. (Fig. 11)
2. Turn the adjuster rod so that the top edge of the cut-out aligns with the line marking just under the word "LATCH" and the rod cut out is facing towards you. (Fig.12)

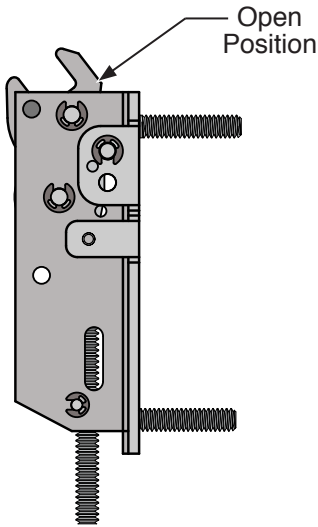

FIG. 10

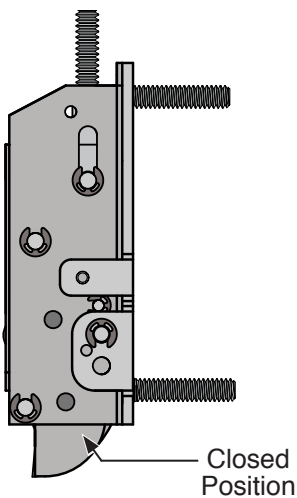

FIG. 11

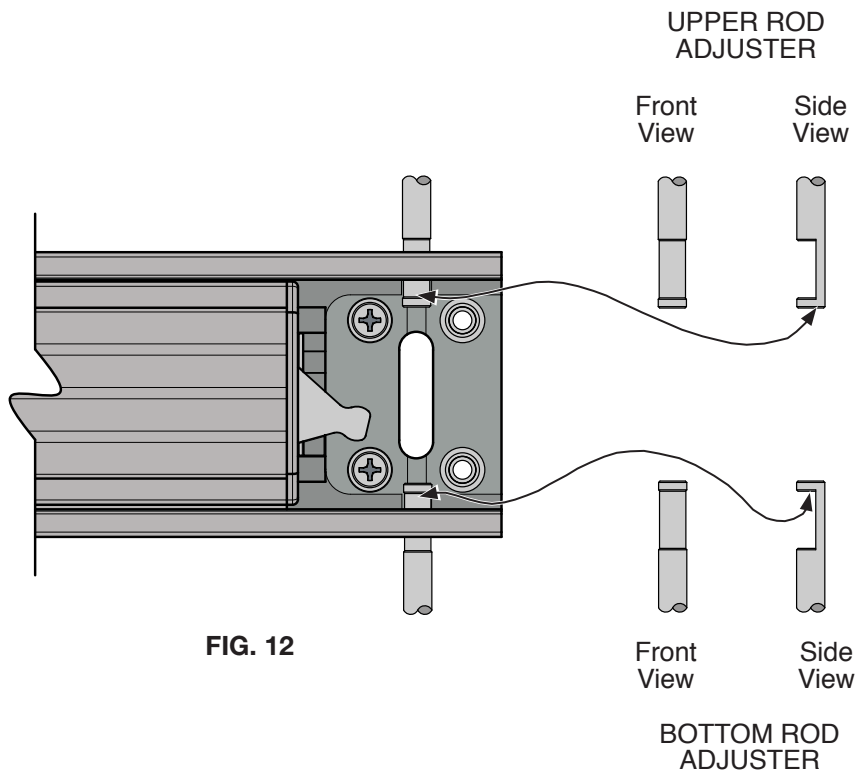

FIG. 12

NOT TO SCALE

DOOR HARDWARE INSTALLATION (CONTINUED)

CONNECTION OF LINKAGE RODS TO THE EXIT DEVICE

1. Bring the upper latch to the closed position. (Fig. 13) The bottom latch should be in the closed position. (Fig. 14)
2. Slide the cruciform (P) under the fixed rollers (Fig. 16), capture both the upper and bottom adjuster rod tabs, and hold in place. (Fig. 15)
3. Install the end cap bracket over the cruciform (P) with (2) 10-32 x 7/8" FHMS (A) on the active stile. (Fig. 16)

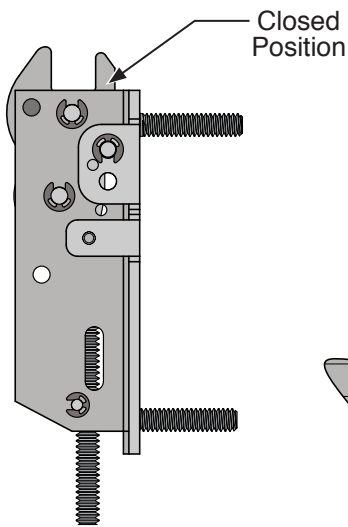

FIG. 13

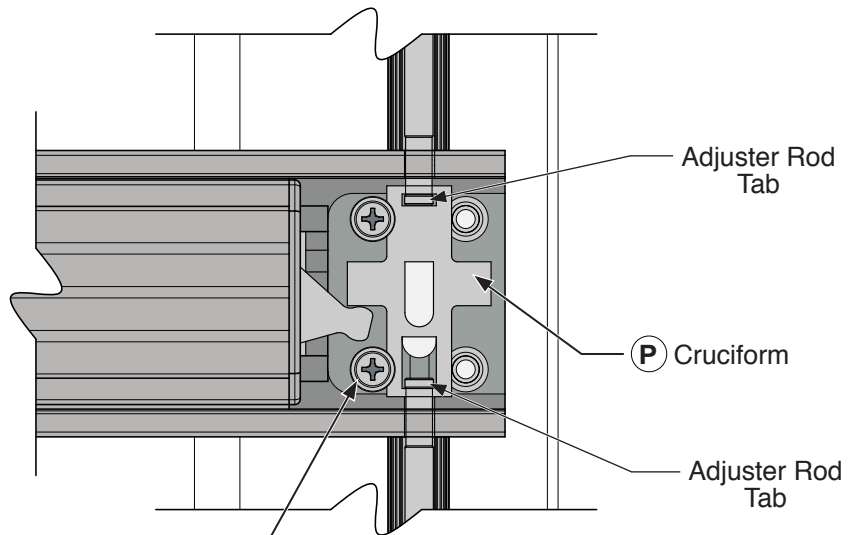

FIG. 15

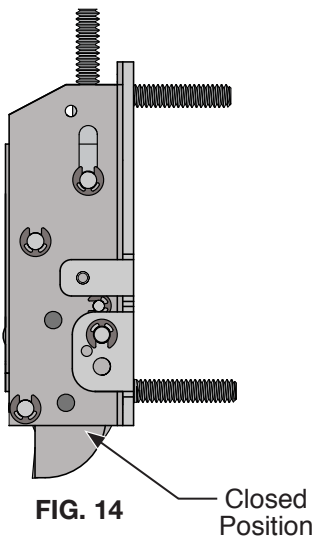

FIG. 14

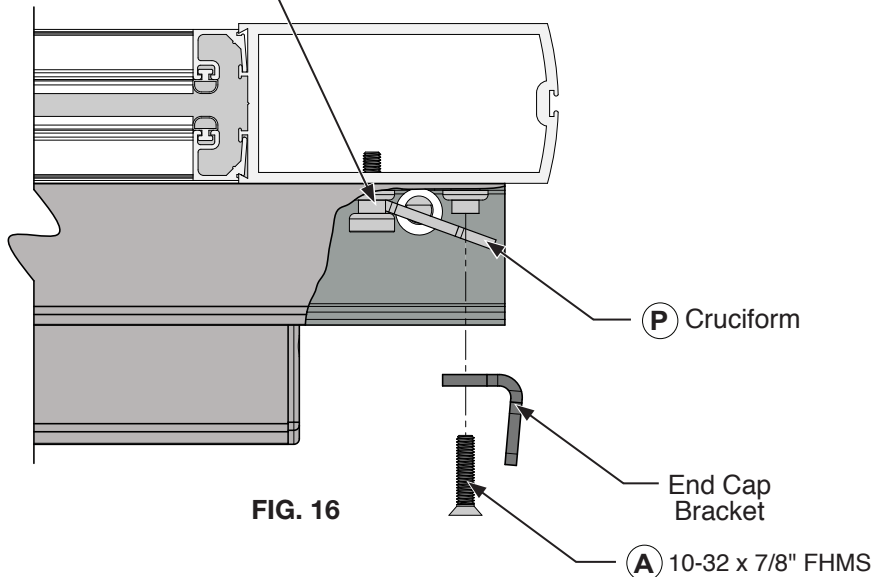

FIG. 16

NOT TO SCALE

DOOR HARDWARE INSTALLATION (CONTINUED)

OPERATIONS CHECK AND DOGGING INSTRUCTIONS

OPERATIONS CHECK:

Depress the push bar to assure free movement of the cruciform assembly. Both upper and bottom latches should activate to the open position. The upper latch should drop into the open position, figure 10. The bottom latch should fully retract. If the latches fail to operate as described, review the rod linkage adjustments on page 13. Verify that the latch and rod adjuster positions align with the markings on the panic bar per (Fig. 12).

DOGGING INSTRUCTIONS:

TO DOG Insert hex dogging key (Cat. No. 302796). Turn key clockwise until it stops. Depress and hold the push bar then release the key. Push bar will remain depressed. Remove key. (Fig. 17)

TO UNDOG Insert hex dogging key and turn clockwise until it stops. While depressing push bar turn and remove key. Push bar will become operable again. (Fig.18)

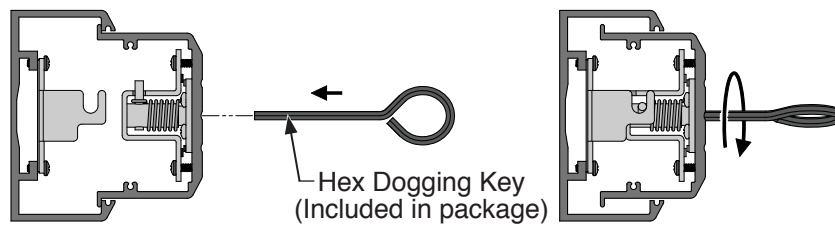

FIG. 17

FIG. 18

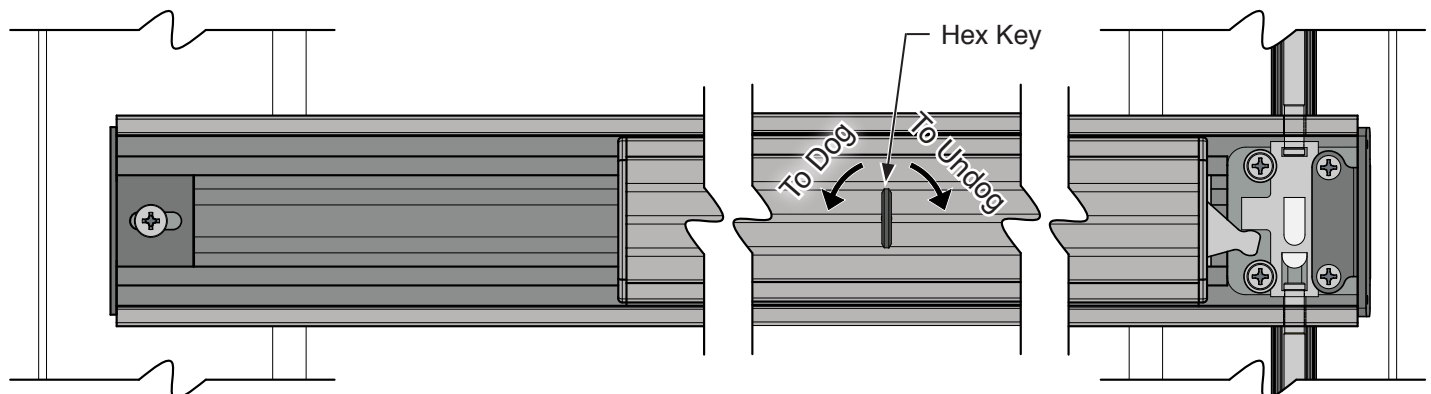

FIG. 19

NOT TO SCALE

DOOR HARDWARE INSTALLATION (CONTINUED)

INSTALL END CAPS AND COVER ASSEMBLIES

1. Slide the (2) base cover plates (N) 302674 in place.
2. Attach both end caps with (4) 8-32 x 3/8" FHMS (K)
3. Snap both the upper and bottom base cover plates (M) over the rod base assemblies 3028527 and 302856.
4. Attach the upper and bottom latch covers to the latch brackets using (4) 6-32 x 1/4" FHMS (H)

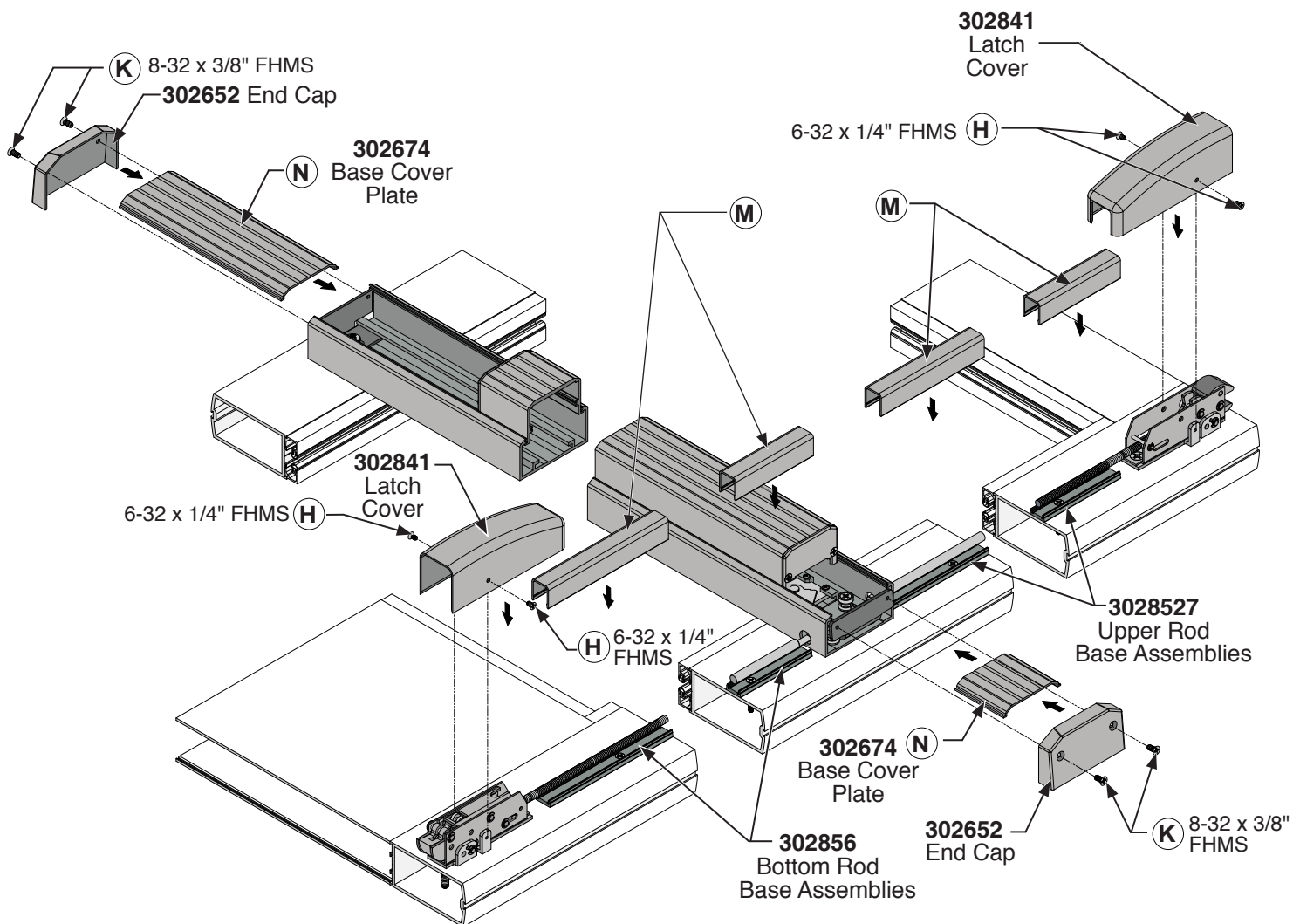

FIG. 20

NOT TO SCALE

FRAME PREPARATION

RE-ATTACH DOOR TO FRAME

1. Make sure that the panic exit device is in the dogged position. Both the upper and bottom latches must clear the frame. Re-attach the door to the frame.
2. With the door in place and in the closed position, mark the center line locations on the header and threshold of both the upper and bottom latches.
3. Finish the header and threshold preparation using the layout drawings on page 17.

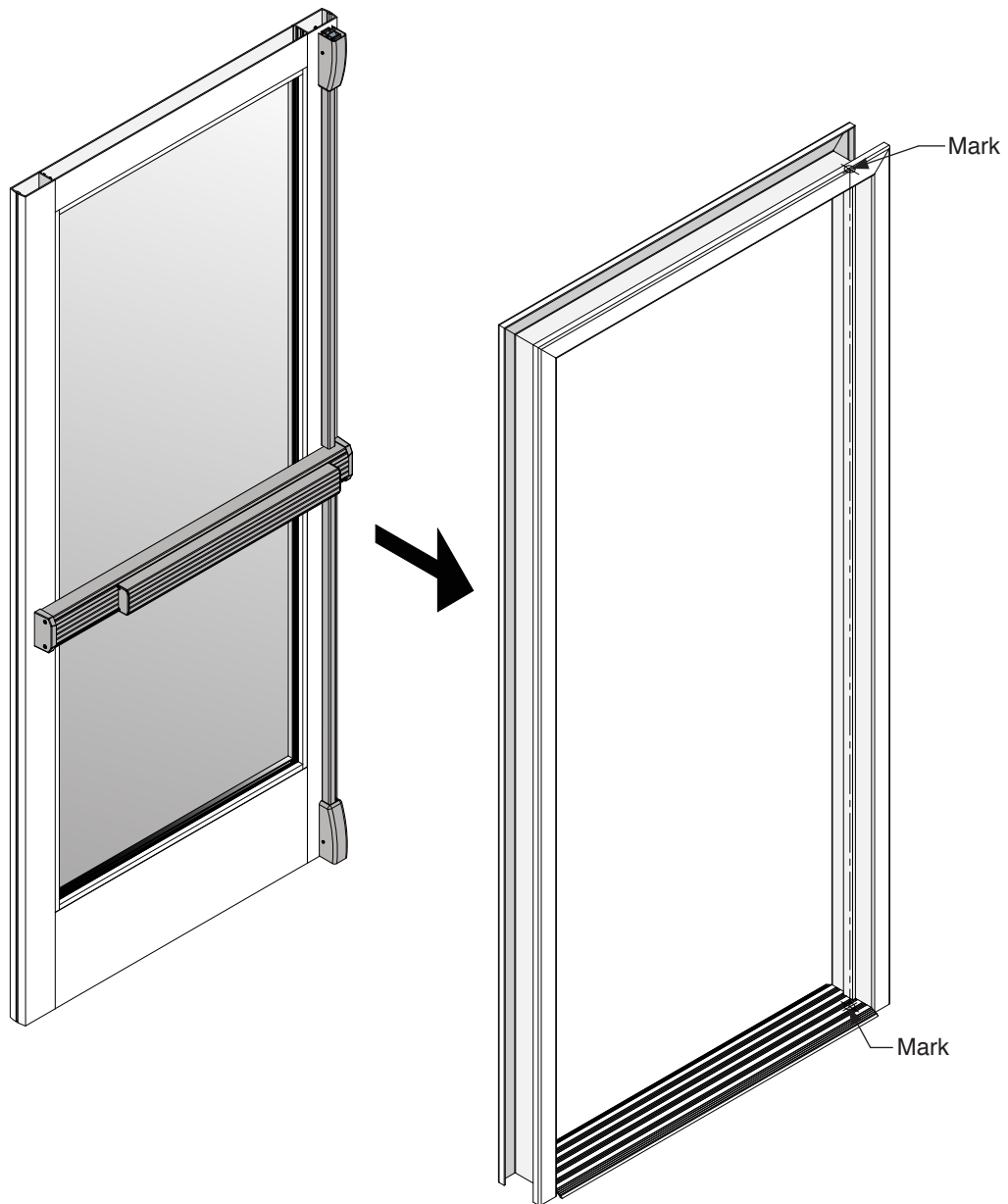

FIG. 21

NOT TO SCALE

FRAME PREPARATION

ATTACH UPPER STRIKE

1. Attach upper strike, use (4) 10-16 x 3/4" FHDS (**Fig. 22**), centering on the mark made in Step 2 of Frame Preparation on page 16. Start with door gap at zero position (**Fig.23**).
2. Test latch engagement.
3. Rotate the strike to increase or decrease gap size between top door rail and stop. (**Fig. 23**)

NOTE: 1/8" max. vertical clearance between door and header must be maintained. Shim strike if necessary.

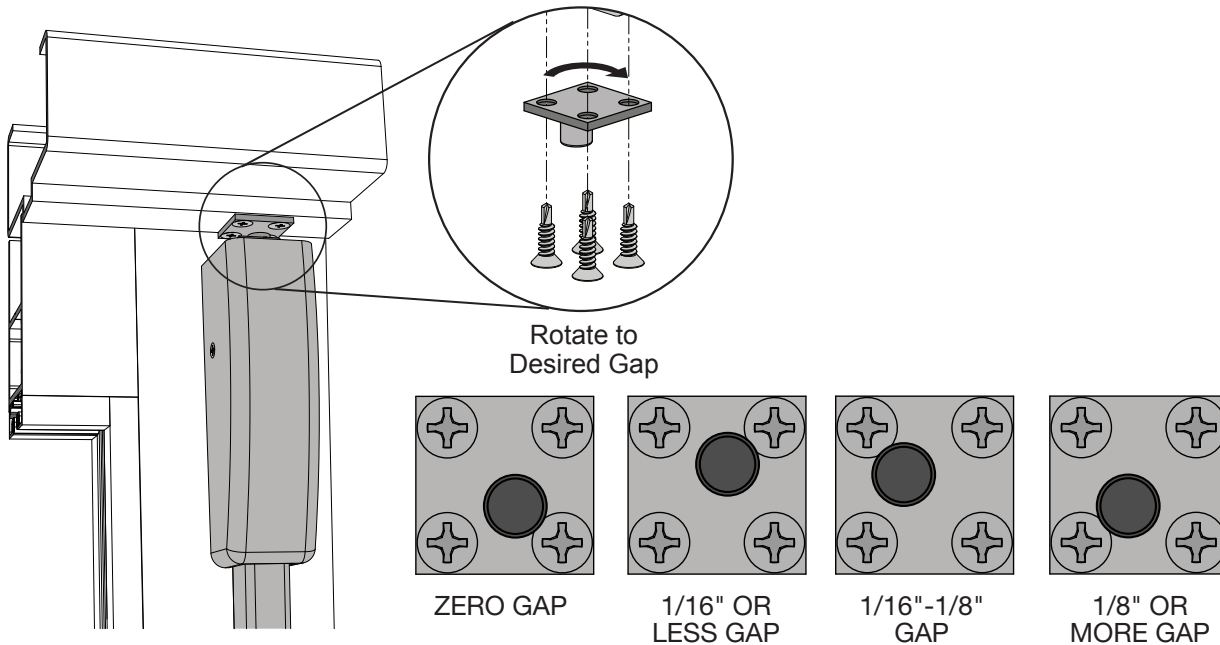

FIG. 22

FIG. 23

ATTACH BOTTOM STRIKE

1. Attach bottom strike as shown in figure 24, centering on the mark.

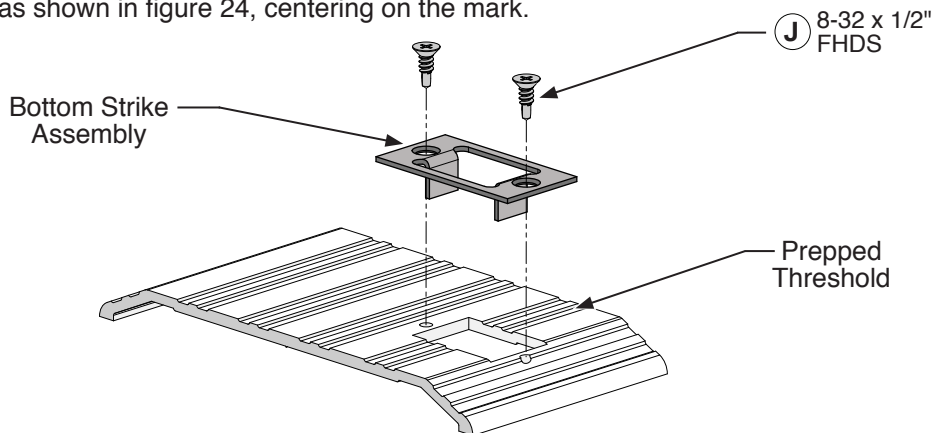
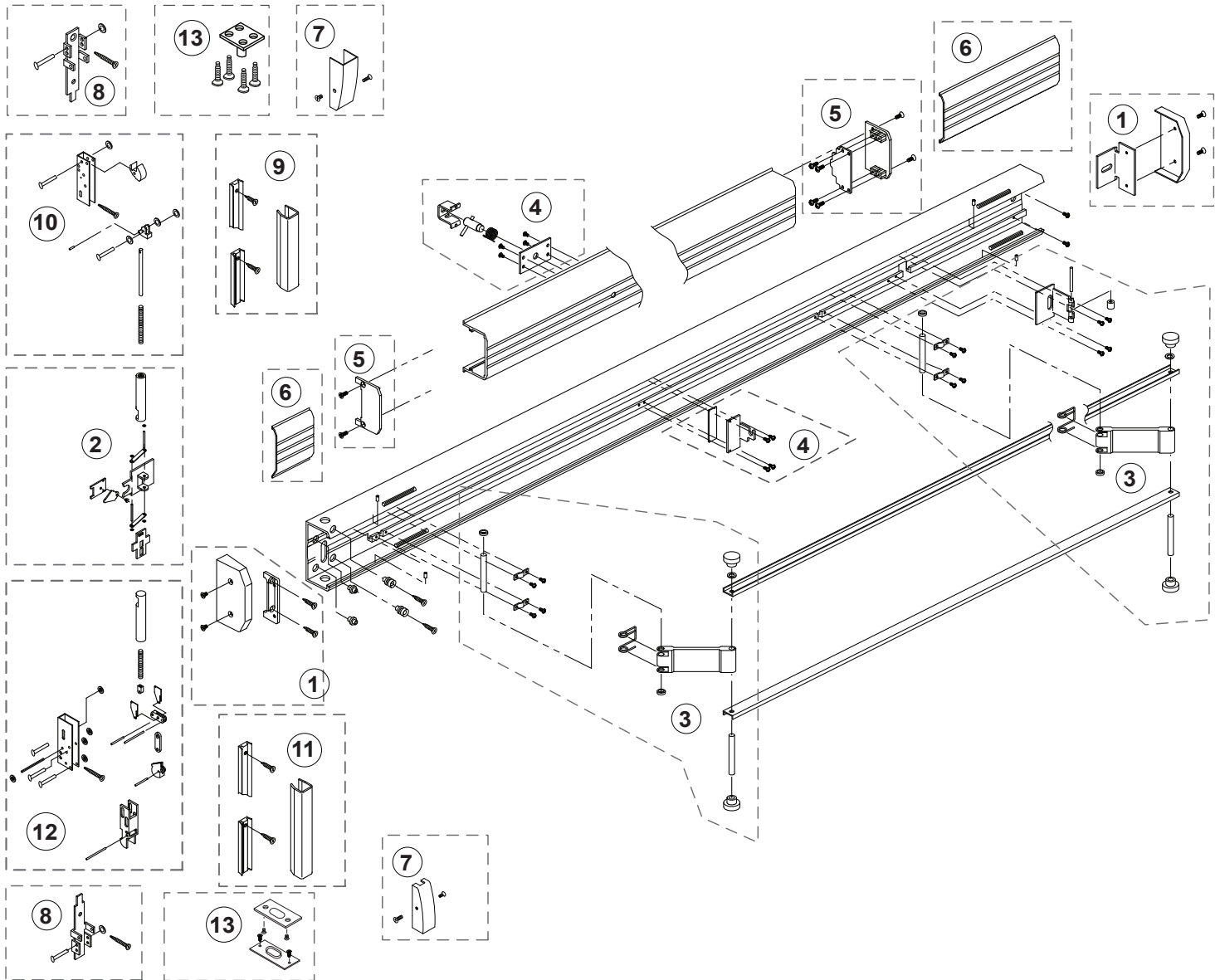

FIG. 24

NOT TO SCALE

PACKAGED PARTS AVAILABLE



Assem. No.	Part No.	Description	Assem. No.	Part No.	Description
1	302652	Base End Cap Package	9	3028528	Top Rod Cover Assembly - 8/0
2	302741ASM	Cruciform Activation Assembly	9	3028529	Top Rod Cover Assembly - 9/0
3	302664	Control Arm Hardware Package	10	3028477	Upper Rod and Latch Assembly - 7'
4	302670	Dogging Assembly	10	3028478	Upper Rod and Latch Assembly - 8'
5	302650	Push-Pad End Cap Package	10	3028479	Upper Rod and Latch Assembly - 9'
6	302674	Base Cover Plate -Ribbed - 3/0	11	302856	Bottom Rod Cover Assembly
6	30267448	Base Cover Plate -Ribbed - 4/0	12	302854	Bottom Rod and Latch Assembly
6	302674S	Base Cover Plate -Smooth - 3/0	13	302113	Upper and Bottom Strike Package
7	302841	Latch Covers (Upper and Bottom)			
8	301856	Latch Bracket Package			
9	3028527	Top Rod Cover Assembly - 7/0			