

USE OF GASKETS

FOR 1/4" (6mm) GLASS: USE ONE THICK GASKET ON EACH SIDE

FOR 5/16" (8mm) GLASS: USE ONE THIN GASKET ON EACH SIDE

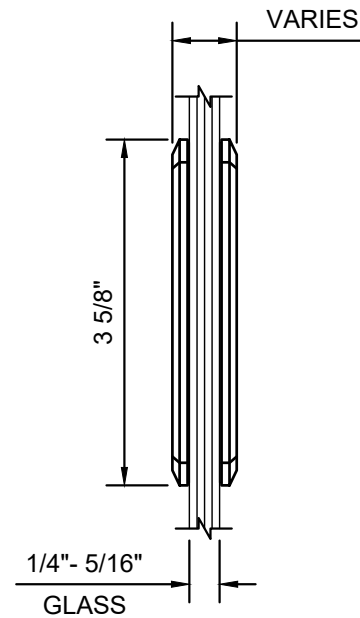
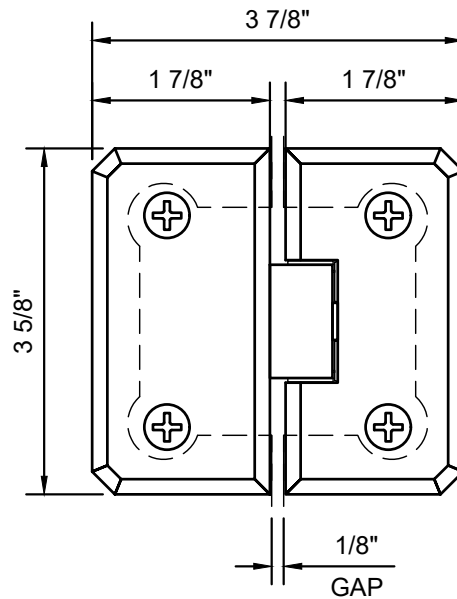
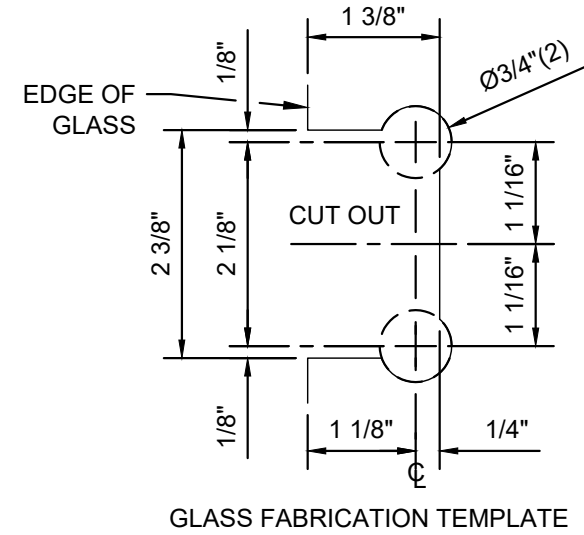
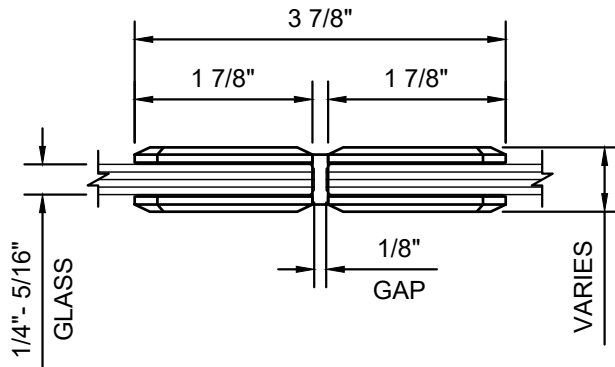

CATALOG NUMBER	FINISH
M0N180CH	POLISHED CHROME
M0N180BR	POLISHED BRASS
M0N180ABN	ANTIQUe BRUSHED NICKEL
M0N180BN	BRUSHED NICKEL
M0N180GP	GOLD PLATE
M0N180SC	SATIN CHROME
M0N180WC	WHITE W/ CHROME ACCENT

M0N180XX - CRL MONACO SERIES 180 DEGREE GLASS TO GLASS HINGE

DATE: 3/1/19
 SCALE: 6"=1'-0"
 DRAWN BY: VM

DESCRIPTION: CRL MONACO SERIES HINGE
 M0N180_ 180° GLASS TO GLASS MOUNT

C.R.LAURENCE CO. ARCHITECTURAL PRODUCTS
 2503 E. Vernon Avenue, Los Angeles, CA 90058-1897
 PH (800)-421-6144 FX: 800-587-7501 www.crlaurence.com

