

**Oldcastle BuildingEnvelope®**

## ***RELIANCE™-HTC INSTALLATION AND GLAZING MANUAL***

**Note:**

The installation details found in this package are generic and are for representation only with the intent of giving the installation team a visual representation as to how the assemblies typically install. The shop drawings and details are the governing documents and as such this package is to be used only as a resource.

Follow sealant manufacturers recommendations for use and application of structural silicone sealant and weather seal silicone sealant.

Note: Customer / Project quality assurance procedures are separate documents and are to be followed in conjunction with this manual.

# RELIANCE™-HTC INSTALLATION MANUAL

## TABLE OF CONTENTS

<b>General Information</b>	
Product Use	1-2
Protection and Storage	3
Check Material	3
Field Conditions	4
Cleaning Materials	4
Expansion Joints	4
Suggestions for Improving System Thermal Performance	4
<b>Installation Types</b>	<b>5</b>
<b>Section 1: Frame Fabrication</b>	<b>6-9</b>
1.1 Measuring Opening	6
1.2 Cutting Material	6
1.3 Vertical Mullion Fabrication	6
1.4 Installing Mullion End Caps	7
1.5 Horizontal Mullion Fabrication	7
1.6 Pressure Plate Weep Hole Fabrication	8
1.7 Additional Pressure Plate Holes (as req'd)	9
<b>Section 2: Frame Installation</b>	<b>10-15</b>
2.1 Vertical Mullion Installation	10
2.2 Horizontal Mullion Installation	12
2.3 Tooling Sealant at Horizontal	13
2.4 Zone Plug & SSG Bridge Installation	13
2.5 Applying Perimeter Seal	13

# RELIANCE™-HTC INSTALLATION MANUAL

## TABLE OF CONTENTS

<b>Section 3: Glazing</b>	<b>16-21</b>
3.1 Pressure Plate and SSG Gasket Installation	16
3.2 Thermal Spacer Installation	16
3.3 Interior Gasket Installation and Sealing	17
3.4 Setting Block Placement	17
3.5 Setting Glass	18
3.6 Temporary Retainer Installation	18
3.7 Side Block Installation	19
3.8 Repeat of Steps 3.3 to 3.7	19
3.9 Sealing For Vertical Pressure Plates	19
3.10 Vertical Pressure Plate Installation	21
3.11 Horizontal Pressure Plate Installation	21
3.12 Final Check of Pressure Plate Torque	21
3.13 Vertical Face Cover Installation	21
3.14 Sealing Tops of Vertical Mullions	21
3.15 Sealing Horizontal Pressure Plates	21
3.16 Horizontal Face Cover Installation	21
<b>Section 4: Supplemental Instructions</b>	<b>23-31</b>
Transition Glazing	23
Vertical Splicing	24
Entrance Frames	27
Reglazing Procedures	30
Corner Mullions	31
<b>Section 5: Parts List</b>	<b>32-37</b>

### Quick Reference Guide

1. Torque pressure plate screws to 90 in-lbs (60 in-lbs at WW-333 temporary retainers)
2. Glass Sizing:
  - Captured System - D.L.O. + 1" for width and height.
  - SSG System - D.L.O. + 2" for width. D.L.O. + 1" for height.
3. Locate pressure plate screws @ 9" o.c. ( 1 1/2" from ends )
4. 1 3/4" glazing system available in two depths: 7 1/4" and 10"
5. 2" glazing system available in two depths: 7 1/2" and 10 1/2"

# RELIANCE™-HTC INSTALLATION MANUAL

## GENERAL INFORMATION

### PRODUCT USE

The **Reliance™-HTC** curtain wall system is intended for fabrication, assembly, sealing, installation and glazing by professionals with appropriate knowledge and experience of the system(s) and their incorporation into various building conditions.

**Consult sealant manufacturer for review and recommendation of sealant application. Follow sealant manufacturer's recommendations and literature for proper installation.**

The fabrication and installation of a structural silicone-glazed (SSG) or wet glazed system requires more technical knowledge and experience than is required for a conventional pressure-glazed or dry glazed system. The glazing contractor should take all steps as outlined and required by the structural silicone sealant manufacturer, glass fabricator, framing manufacturer, and the project professional engineer of record as well as follow local building code requirements and industry best practices to ensure the proper installation and safe performance of the SSG system.

The glazing contractor for each project needs to ensure compliance with each step, including, but not limited to, design reviews, formal adhesion testing, formal compatibility testing, project specification compliance, validating procedures, field testing, and quality control validation of installed product and surrounding conditions.

Testing of component materials for use in a SSG or wet glazed system is mandatory to fulfill project specifications and warranty requirements and must be submitted by the glazing contractor to the structural silicone manufacturer. All materials that comprise the structural silicone joint, such as the framing system (with the job-specific finish) and job-specific glass must be tested by the structural silicone manufacturer for compatibility and adhesion. All other accessory materials in contact with the structural silicone, such as setting blocks, spacers, gaskets, sweeps, air seals and expansion joints, must also be submitted to the silicone sealant manufacturer for compatibility testing.

To ensure that nothing has changed in formulation or chemistry since the initial tests, subsequent testing during periodic time frames of the project is to be conducted to confirm continued acceptance of the material for use on the project. To ensure the structural performance and integrity of the insulating glass unit (IGU), the glazing contractor must submit the project shop drawings to the glass fabricator to obtain approval for use of their product(s) in any 2, 3 or 4-sided SSG applications.

Quality control procedures for field glazing are to be increased beyond those required for shop glazing. Job conditions will normally have dust, dirt, and other construction debris on the surfaces where structural silicone is to be applied. Great care should be exercised in cleaning and preparing these surfaces for silicone application. The recommendations of the silicone sealant manufacturer are to be strictly enforced and followed. The fabrication and installation of the SSG system and its components, whether shop or field glazed, should be governed by a quality control program, and all steps, procedures, and test reports should be documented throughout the project.

Prior to installation of any SSG system, refer to industry documents (e.g., AAMA Curtain Wall Design Guide Manual, ASTM C1401-14, and AAMA SSGDG-17) for detailed instructions and recommendations.

# RELIANCE™-HTC INSTALLATION MANUAL

**THE GLAZING CONTRACTOR ASSUMES FULL RESPONSIBILITY FOR ENSURING COMPLIANCE WITH THE ABOVE AND ASSUMES FULL LIABILITY FOR ANY ISSUES ARISING FROM NONCOMPLIANCE.**

## GLAZING PRACTICES

The air and water performance of the **Reliance™-HTC** curtain wall system is directly related to the completeness and integrity of the installation process, including but not limited to the assembly seals of the framing joinery, the installed glazing gaskets, and the alignment of the framing joinery glazing plane. Before glazing, verify the glazing pocket width and glazing infill thickness, as both must be in tolerance to assure adequate edge pressure and to achieve the desired air and water performance levels. (In general, framing systems utilizing 1" insulating glass are designed to accommodate a thickness variance of +/- 1/32"). Note: Excessive pressure can cause glass breakage and/or IGU failure. Consult the glass manufacturer for their recommended edge pressure per lineal inch. To achieve the designed and tested air and water performance, best practices include:

1. Surfaces to be sealed should be cleaned with isopropyl alcohol or solvent and dried as recommended by sealant manufacturer to remove all dirt and cutting oils. Sealant at shear blocks should be a minimum 3/16" diameter nominal placed completely around the top, face and bottom of the shear block without gaps in the sealant. Exposed surfaces should be cleaned after installing the horizontal. Inspect joint for complete sealant contact, especially where the horizontal meets the face of the vertical member. Repair joint as required.
2. Glazing gaskets should be cut ¼" longer per foot, and lay flat, preferably for 24 hours.
3. Gaskets should be cut as single monolithic pieces and "crowded" during their installation to avoid corner gaps caused by post-installation relaxation.
4. The interior glazing gasket should be installed so as to avoid stretching, buckles, or tears.
5. Corners must be cut square, and at a slight angle when required to conform to the bevel on the intersecting gasket; sealed and butted together.
6. Gasket corner joinery must also be crowded, and sealant applied onto the gasket contact frame surface and into gasket reglet raceway where applicable.
7. Gasket corner seals are to be done just prior to installing glass, while the sealant is still wet and uncured, and ensure exterior gaskets are installed so as to place the glass into it's final in service condition and allow the sealant to conform to optimum configuration. Note: If the sealant cures prior to glazing, the cured sealant could create excessive edge pressure onto the glass and has the potential to cause glass breakage.
8. The glass must be checked for squareness, size dimension, and thickness along the edges paying attention to any variances from center edge to corner edge.
9. Check the placement of the installed glass and verify there is proper edge bite into the pocket, and proper edge clearance from framing elements.
10. After sealant has set and a representative amount of the wall has been installed and glazed (250 square feet or more) run a water hose test in accordance with AAMA 501.2 specifications to check installation. On large projects the hose test should be repeated during the glazing operation. Consult and follow NGA's GANA Manual and FGMA Glazing Manual for proper glazing technique and procedure.

Variations on the details shown are inevitable and are not the responsibility of Oldcastle BuildingEnvelope when drawn by others. Oldcastle BuildingEnvelope strongly encourages its customers to utilize Oldcastle BuildingEnvelope supplied calculations and shop drawings.

# RELIANCE™-HTC INSTALLATION MANUAL

For Structural Silicone Glazing applications, the stress on the silicone should not exceed 20 PSI. Consult sealant manufacturer for specific applications to ensure proper loading on silicone joint. Alternate spacer gaskets are available to accommodate larger sealant contact widths. Consult your nearest Oldcastle BuildingEnvelope facility for assistance.

Consult glass manufacturer for correct setting block location and length for glass sizes in excess of 40 sq.ft.

## BUILDING CODES

Oldcastle BuildingEnvelope® does not control the application nor selection of its product configurations, sealant, or glazing materials, and assumes no responsibility thereof. It is the responsibility of the owner, architect, and installer to make these selections in strict compliance with applicable laws and building codes.

## PROTECTION AND STORAGE

Handle all material carefully. Do not drop from the truck. Stack with adequate separation so the material will not rub together. Store material off the ground, protecting against the elements and other construction hazards by using a well ventilated covering. Remove material from package if wet or located in a damp area. For further guidelines consult AAMA publication CW-10 "Care and Handling of Architectural Aluminum From Shop to Site."

## CHECK MATERIAL

Check glass dimensions for overall size as well as thickness. Oldcastle BuildingEnvelope cannot be held responsible for gaskets that are not water tight due to extreme glass tolerances. The Reliance-HTC curtain wall system is designed to accommodate glass or panels measuring 1-3/4" and 2" in thickness (+/- 1/32").

Check all material upon arrival at job site for quality and to determine any shipping damage.

Using the contract documents, completely check the surrounding conditions that will receive your materials. Notify the general contractor by letter of any discrepancies before proceeding with the work. Failure to do so constitutes acceptance of work by other trades.

Check shop drawings, installation instructions, architectural drawings and shipping lists to become familiar with the project. The shop drawings take precedence and include specific details for the project. The installation instructions are of a general nature and cover the most common conditions. Due to varying job conditions all sealant used must be approved by the sealant manufacturer to ensure it will perform per the conditions shown on the instructions and shop drawings. The sealant must be compatible with all surfaces in which adhesion is required, including other sealant surfaces. Use primers where directed by sealant manufacturer. Properly store sealant at the recommended temperatures and check sealant for remainder of shelf life before using.

# RELIANCE™-HTC INSTALLATION MANUAL

## FIELD CONDITIONS

All material to be installed must be plumb, level and true. Aluminum to be placed in direct contact with masonry or incompatible material should be isolated with a heavy coat of zinc chromate, bituminous paint or non-metallic material.

After sealant is set and a representative amount of the wall has been glazed (250 square feet or more), run a water hose test in accordance with AAMA 501.2 specifications to check installation. On large projects the hose test should be repeated during the glazing operation.

## CLEANING MATERIALS

Cement, plaster terrazzo, alkaline and acid-based materials used to clean masonry are very harmful to finishes. Any residue should be removed with water and mild soap immediately or permanent staining will occur. A spot test is recommended before any cleaning agent is used. Refer to the Architectural Finish Guide in the Detail Catalog.

## EXPANSION JOINTS

Expansion joints and perimeter joints shown in these instructions and in the shop drawings are shown at nominal size. Actual dimensions may vary due to perimeter conditions and/or differences in metal temperature between the time of fabrication and the time of installation. For example, a 12-foot unrestrained length of aluminum can expand or contract 3/32" over a temperature change of 50° F. Any movement potential should be accounted for at the time of the installation.

## SUGGESTIONS FOR IMPROVING SYSTEM THERMAL PERFORMANCE

To maintain or improve your wall installation the following items should be considered.

- A. Blinds or drapes prevent warm air from adequately flowing over the window surface.
- B. Warm air ventilators too far from the window will not adequately wash the window with air to prevent condensation.
- C. In extreme conditions the fan of the heating system should not cycle on and off but should run continuously.
- D. Some heating systems have a water injection feature that can raise humidity levels. The higher the humidity levels the more likely condensation or frost will form. Raising the temperature and reducing humidity will usually solve the problem.
- E. On rare occasions an extremely cold storm may cause frost to appear on the glass framing. A space heater and electric fan blowing along the plane of the window wall can reduce or eliminate this temporary condition.

# RELIANCE™-HTC INSTALLATION MANUAL

## INSTALLATION TYPES

The following wall sections represent common types of installations for this product. Refer to approved shop drawings for specifics regarding splicing and anchoring of frame.

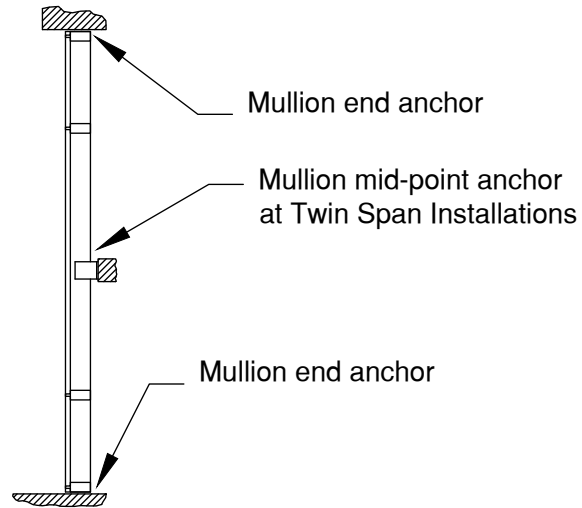

Single Span & Twin Span  
Refer to steps 2.1.1 through 2.1.5

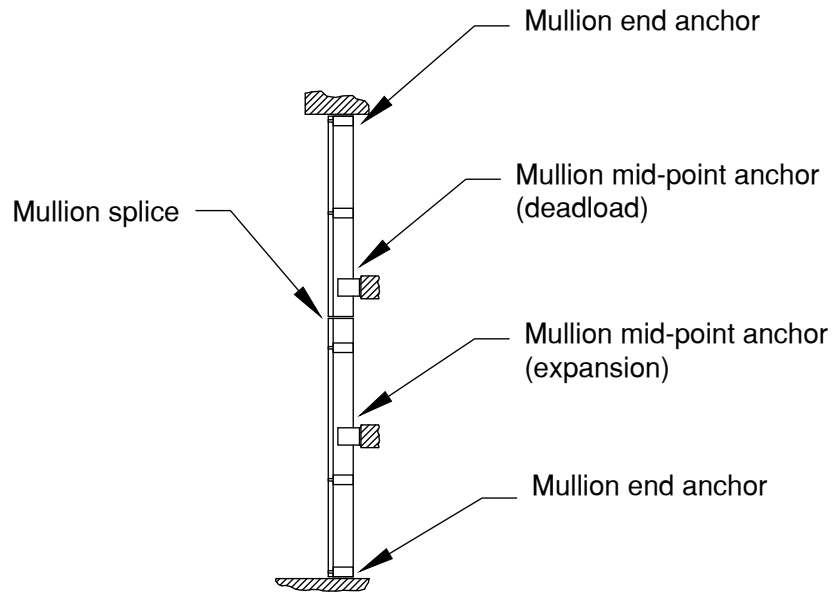

Multi-Span  
Refer to steps 2.1.6 through 2.1.13

# RELIANCE™-HTC INSTALLATION MANUAL

## FRAME FABRICATION

Unless otherwise noted, the details shown in these instructions reflect the 7 1/4" system for 1 3/4" glazing. 7 1/2" system for 2" glazing is similar. Fabrication instructions for 10" and 10 1/4" depths (1 3/4" and 2" glazing, respectively) are noted in these instructions.

**NOTE : Structural silicone glazed vertical mullion is referred to as " SSG mullion"**

1.1 Measure ROUGH OPENING to determine FRAME WIDTH and FRAME HEIGHT dimensions. Allow 1/2" minimum clearance for shimming and caulking around perimeter of frame.

1.2 Cut material to size. **SEE FIGURE 1** for guide.

### Frame Members

Verticals	FRAME HEIGHT (ROUGH OPENING minus top & bottom joints)
Vertical pressure plates .....	FRAME HEIGHT minus 1/4"
Vertical face covers.....	FRAME HEIGHT (vertical covers run through)
Intermediate horizontals (tubular).....	Daylight opening (D.L.O.)
Head and sill.....	D.L.O. minus 1/16"
Horizontal pressure plates.....	D.L.O. minus 1/4"
Horizontal face covers.....	D.L.O. minus 1/16"

### Accessories

Glazing gaskets	
Exterior.....	Pressure plate length plus allowance*
Interior at verticals.....	D.L.O. plus 1" plus allowance* (vertical gaskets run through)
Interior at horizontals.....	D.L.O. plus allowance*
Silicone spacer gaskets.....	D.L.O. plus 1" plus allowance*

\*Glazing gaskets should be cut 1/4" longer per foot. Set aside and lay flat until ready to glaze.

### Other Members (as required)

Glazing adaptors	
Horizontal.....	D.L.O. minus 1/4"
Vertical.....	D.L.O. plus 3/4" (notching required at captured mullions <b>SEE FIGURE 19)</b>

Door subframe	
Jamb.....	DOOR OPENING plus 1"
Header.....	DOOR OPENING

1.3 Fabricate vertical mullions for horizontal members using DJ-113. Drill holes for shear block using holes marked with "A" and "B" for 7 1/4" and 7 1/2" system, and "A" and "C" for 10" and 10 1/4" system. Consult with engineer to determine number of screws required for each shear block based on actual job conditions. **SEE FIGURE 2, page 8.** When working off horizontal centerlines, use the slot milled into the drill jig for aligning jig with centerline.

# RELIANCE™-HTC INSTALLATION MANUAL

## FRAME FABRICATION

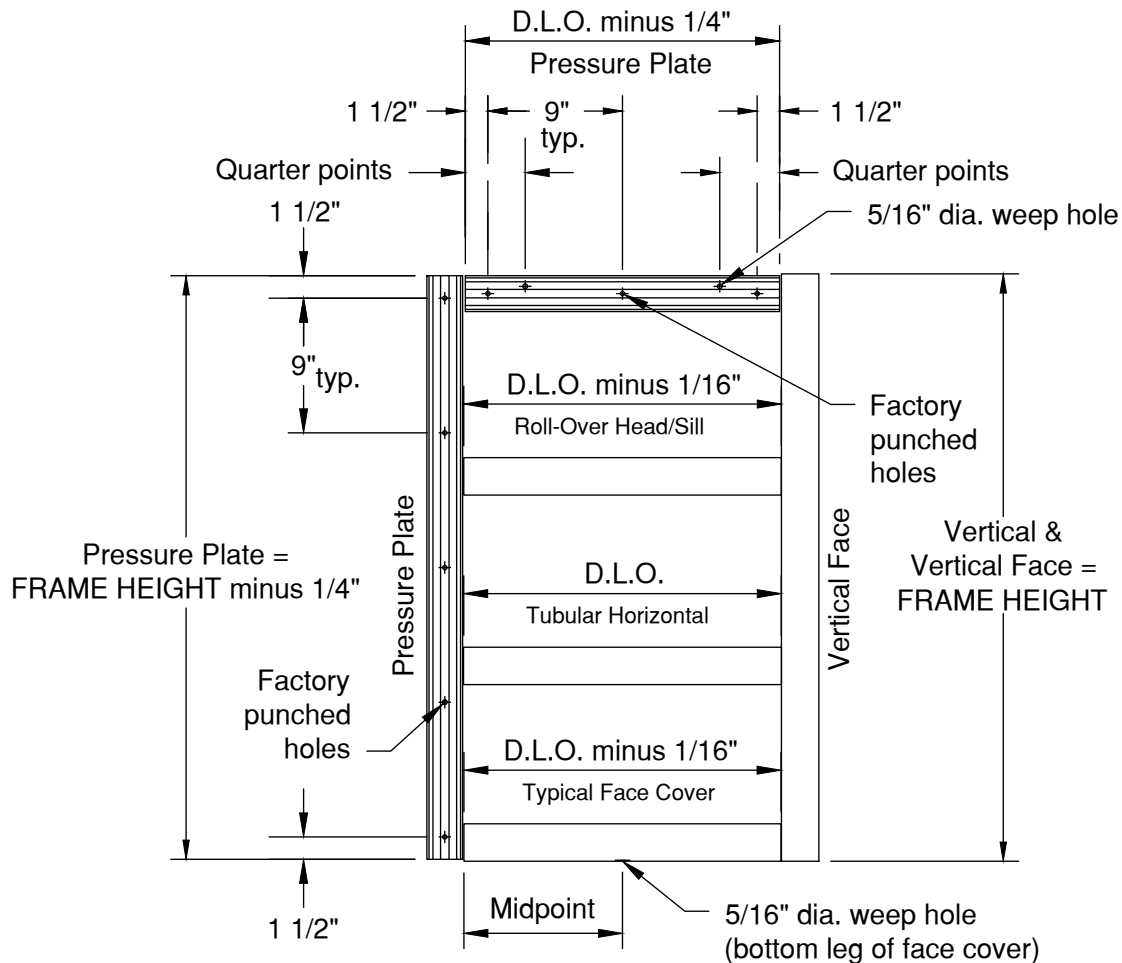
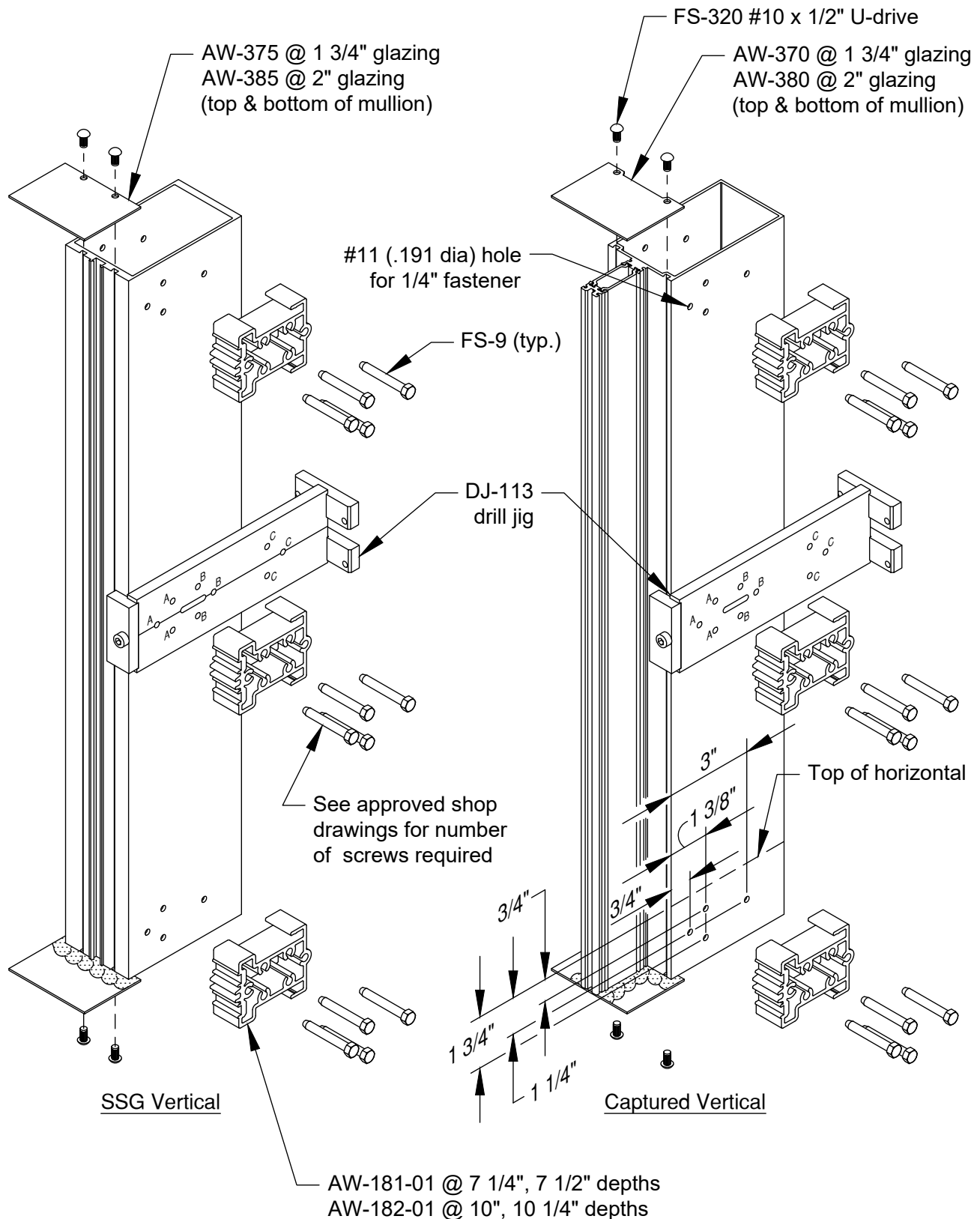

**FIGURE 1**  
**Material Fabrication Guide**

- 1.4 Install and seal mullion caps to top and bottom of all jamb and intermediate vertical mullions with (2) FS-320 #10 x 1/2" Drive screw. **SEE FIGURE 2.** Mullion caps at jambs must be modified. **SEE FIGURE 10.**
- 1.5 Fabricate ends of horizontal members for shear block screws, using DJ-113 drill jig. **SEE FIGURE 3.** **Note: When fabricating horizontals, use the side of the drill jig stamped " Horizontal" . When fabricating head and sill horizontals, use the side stamped " Head/Sill/Rollover" .**

# RELIANCE™-HTC INSTALLATION MANUAL

## FRAME FABRICATION



**FIGURE 2**  
**Vertical Fabrication**

# RELIANCE™-HTC INSTALLATION MANUAL

## FRAME FABRICATION

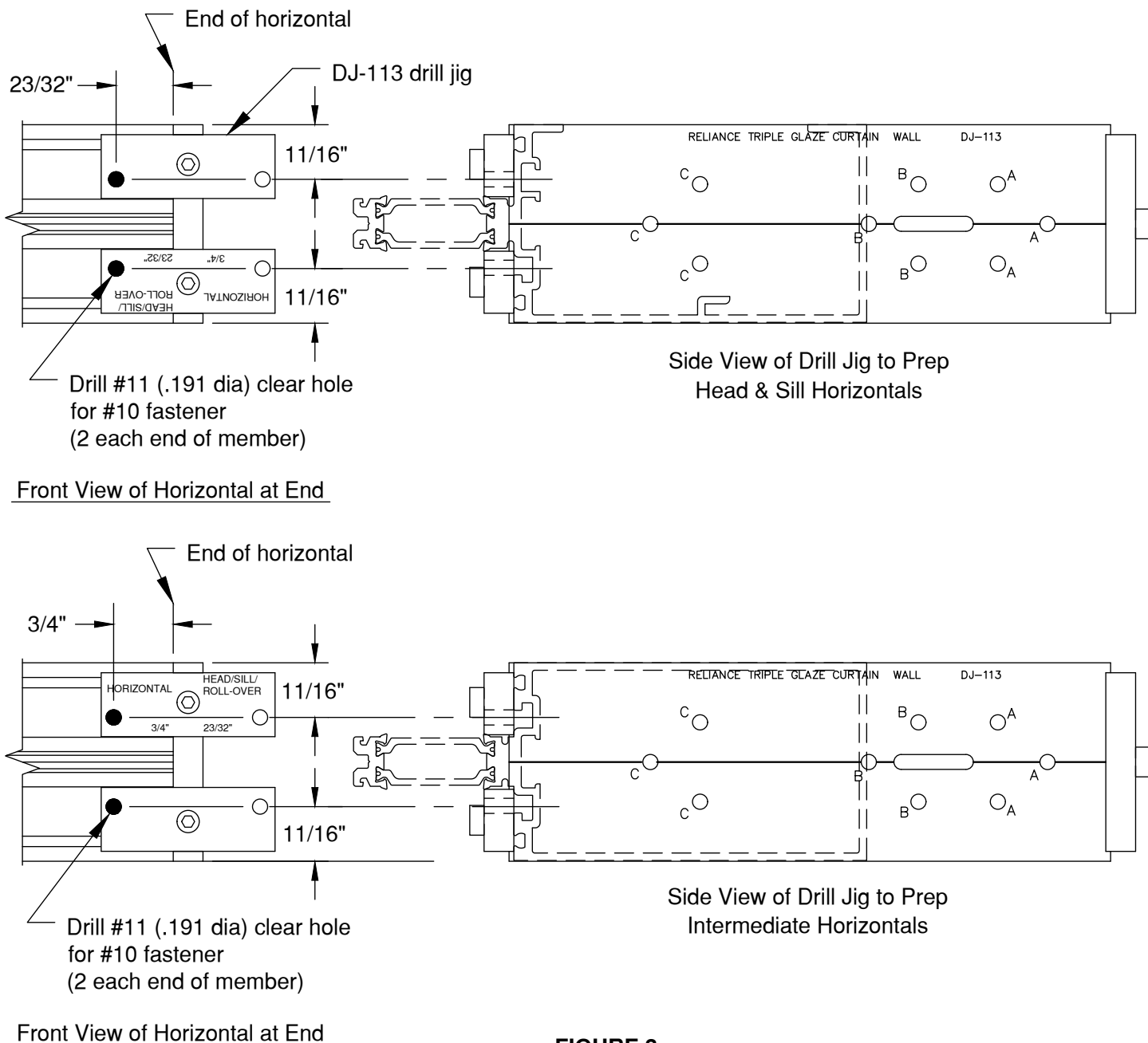

**FIGURE 3**  
**Horizontal Fabrication**

1.6 Drill 5/16" diameter weep holes at 1/4 points in the horizontal pressure plate. Drill (1) 5/16" diameter weep hole at the bottom of each horizontal face cover at centerline of D.L.O. **SEE FIGURE 18. NOTE: For SSG applications, face covers typically run across mullions, so there will be multiple holes in each horizontal face cover.**

1.7 All pressure plates have factory-punched holes for screws at 9" O.C. To ensure proper pressure on the glazing, 7/32" diameter holes may need to be drilled at the ends of each pressure plate as required. Locate at 1 1/2" maximum from the ends

# RELIANCE™-HTC INSTALLATION MANUAL

## FRAME INSTALLATION

Anchor type and sizes vary per job requirements. Details shown in these instructions are to be used as a guide only. Refer to approved shop drawings for actual conditions.

### 2.1 Vertical mullion installation:

#### SINGLE & TWIN SPAN INSTALLATION:

2.1.1 Attach shear blocks to all vertical members. **SEE FIGURE 4** for proper orientation on mullion.

2.1.2 Slide tee anchors into top and bottom of vertical mullions. The tee anchors are designed to clear the shear block fasteners. **Note: Maximum end reaction allowed at head and sill using tee anchors is 750 pounds.**

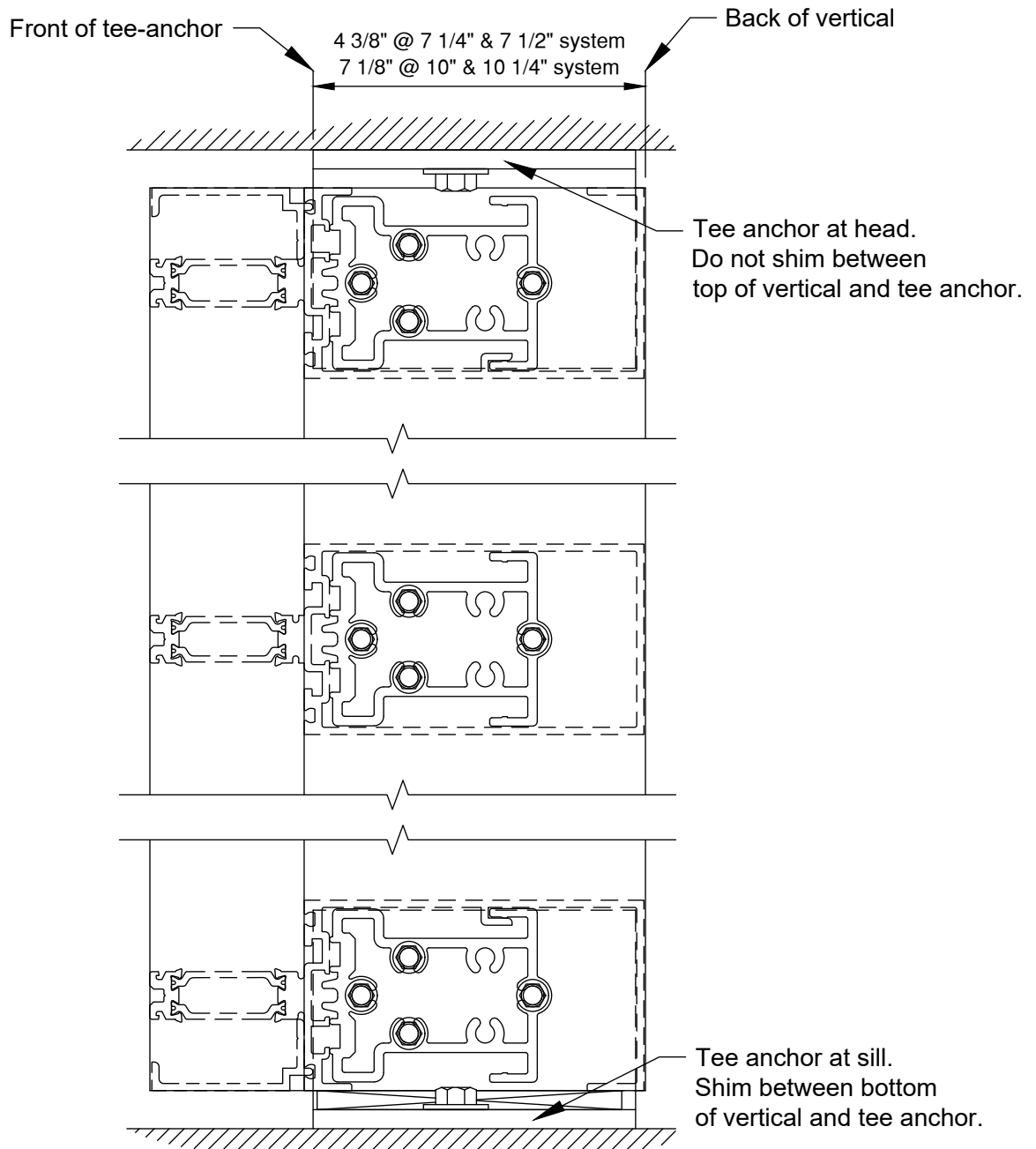

**FIGURE 4**  
**Shear Block Orientation & Mullion Anchoring**

# RELIANCE™-HTC INSTALLATION MANUAL

## FRAME INSTALLATION

### SINGLE & TWIN SPAN INSTALLATION (cont'd):

2.1.3 Install verticals plumb and level, ensuring proper spacing out from floor slab or beam. Place shims under vertical mullion (tee anchor is set on building condition) and anchor at sill to evenly distribute deadload from wall. Anchor top and bottom of mullions to structure.

**NOTE: Last bay intermediate horizontals must be notched. SEE FIGURE 6.**

2.1.4 Anchor the mullion to floor slab or beam. Do not overtighten bolt(s). For expansion anchors, back off nut ¼ turn and stake bolt.

2.1.5 Check D.L.O. every four bays to ensure correct spacing and prevent dimensional buildup.

### MULTI-SPAN INSTALLATION:

2.1.6 Install tee anchors at the sill condition prior to setting mullions. Each tee anchor must be anchored with a minimum of two anchor bolts. See approved shop drawings for bolt size and location.

2.1.7 Attach shear blocks to all vertical members. **SEE FIGURE 2, page 8** for proper orientation on mullion.

2.1.8 Install lower verticals plumb and level, ensuring proper spacing out from floor slab or beam. Place shims under vertical mullion at sill to evenly distribute deadload from wall. **NOTE: Last bay intermediate horizontals must be notched. SEE FIGURE 6.**

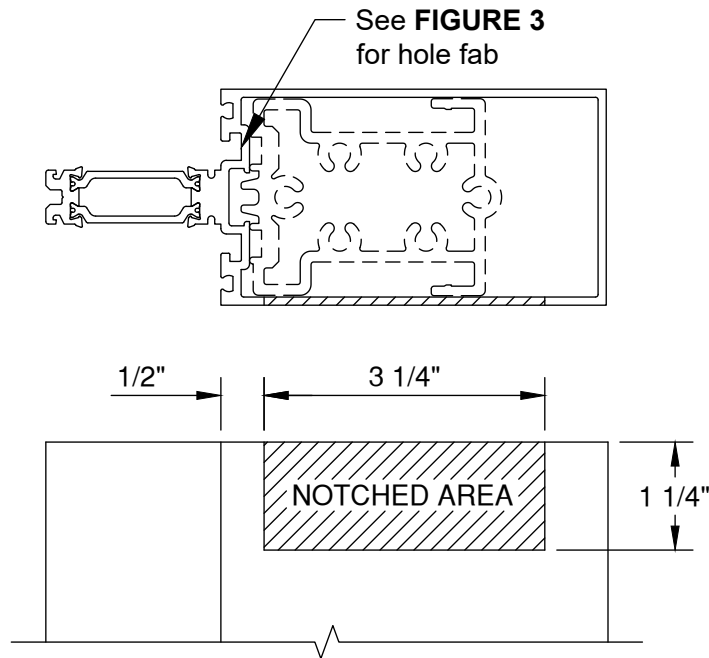

**FIGURE 6**  
**Last Bay Horizontal Notch**

# RELIANCE™-HTC INSTALLATION MANUAL

## FRAME INSTALLATION

### MULTI-SPAN INSTALLATION (cont'd):

- 2.1.9 Anchor the mullion to floor slab or beam. Do not overtighten bolt(s).
- 2.1.10 Repeat steps 2.1.8 and 2.1.9 until all lower verticals are in place. Check the D.L.O. every four bays to ensure correct spacing and prevent dimensional buildup.
- 2.1.11 Install the next vertical above, temporarily shimming between verticals to maintain proper splice joints (refer to approved shop drawings). **SEE FIGURE 7.**
- 2.1.12 Slide tee anchors into top of upper-most mullions. The tee anchors are designed to clear the shear block fasteners. Attach tee anchor to building condition.
- 2.1.13 When the wall is set, remove shims between vertical mullions at splices, back off nut ¼ turn at expansion anchors and stake bolts.

**Continue with step 2.2 for remaining installation after all verticals have been erected.**

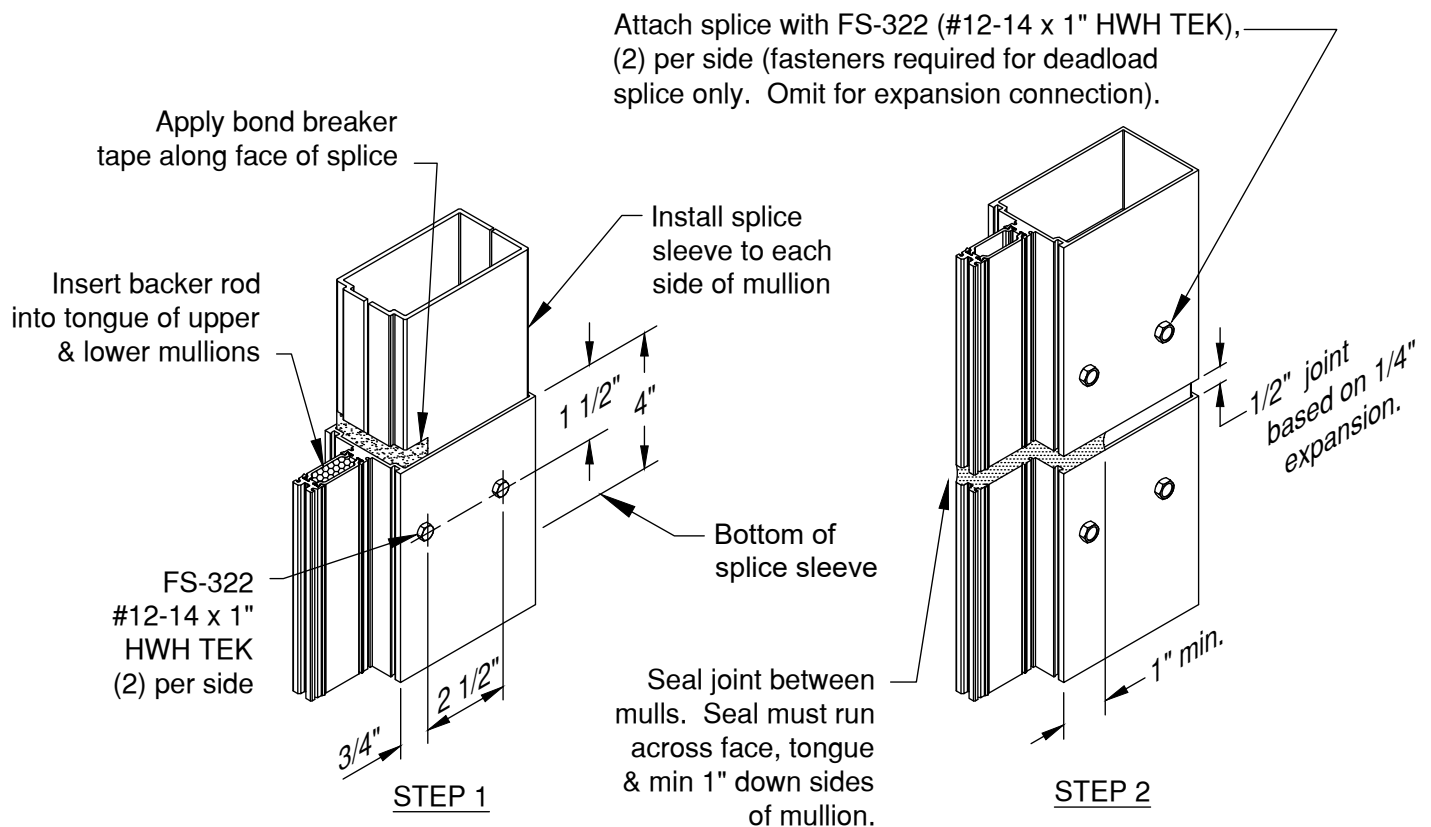

**FIGURE 7**  
**Vertical Splicing**  
**(Captured Mullion Shown; SSG Similar)**

- 2.2 Seal around shear blocks prior to installing each horizontal mullion. Install horizontal mullions as shown in **FIGURE 8**. Prior to attaching screws, make sure sealant has been forced out of the holes in horizontal. If not, apply a liberal amount of sealant into each hole. Secure horizontals to shear block with two (2) FS-115 #10 x 1" Phillips Pan Head screw at each end of horizontal. Check head of screw to insure proper seal, sealing track on each side of screw.

# RELIANCE™-HTC INSTALLATION MANUAL

## FRAME INSTALLATION

- 2.3 Wipe excess sealant from exposed areas. Tool sealant into the joint between the horizontal and vertical at the glazing pocket. Avoid a buildup of sealant on the gasket surfaces or in the gasket reglets. **TIP: Use a short piece of interior glazing gasket to clean out excess sealant in glazing reglets.**
- 2.4 Apply sealant to all contact surfaces on vertical and horizontal mullions where zone plugs will be installed. Apply sealant to horizontal tongue receptor on zone plug and install at the end of each horizontal, head and sill. Tool any excess sealant around front end of zone plug where thermal spacer abuts the zone plug. Tool sealant in the glazing pockets to ensure a watertight fit. **SEE FIGURE 9, page 14.**
- 2.5 When all framing members are installed, apply the perimeter seal. **SEE FIGURE 10, page 15.** The interior perimeter seal is not required for system performance, but can be installed for cosmetic purposes. Perimeter sealing must be completed prior to glazing.

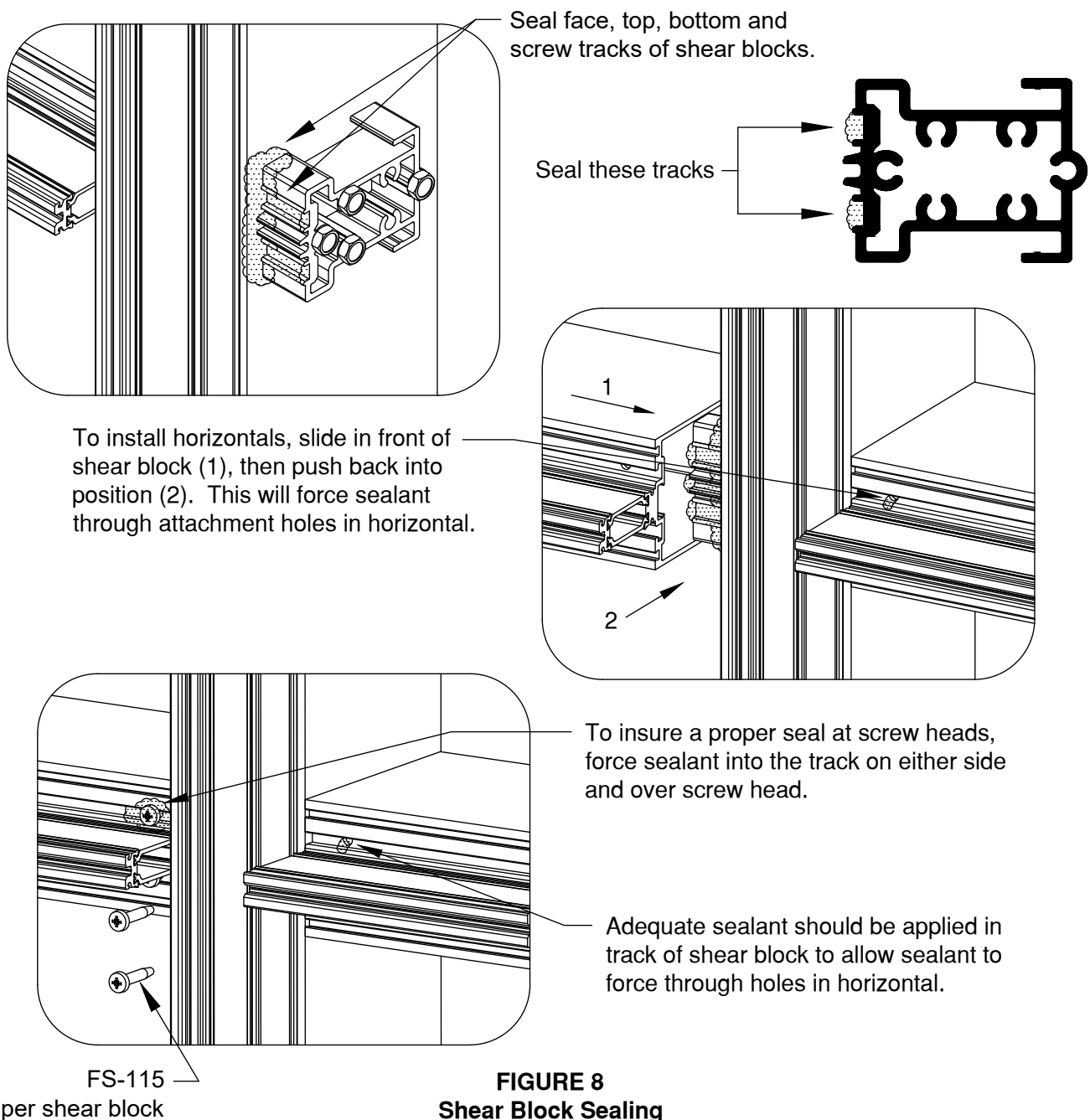

**FIGURE 8**  
**Shear Block Sealing**

# RELIANCE™-HTC INSTALLATION MANUAL

## FRAME INSTALLATION

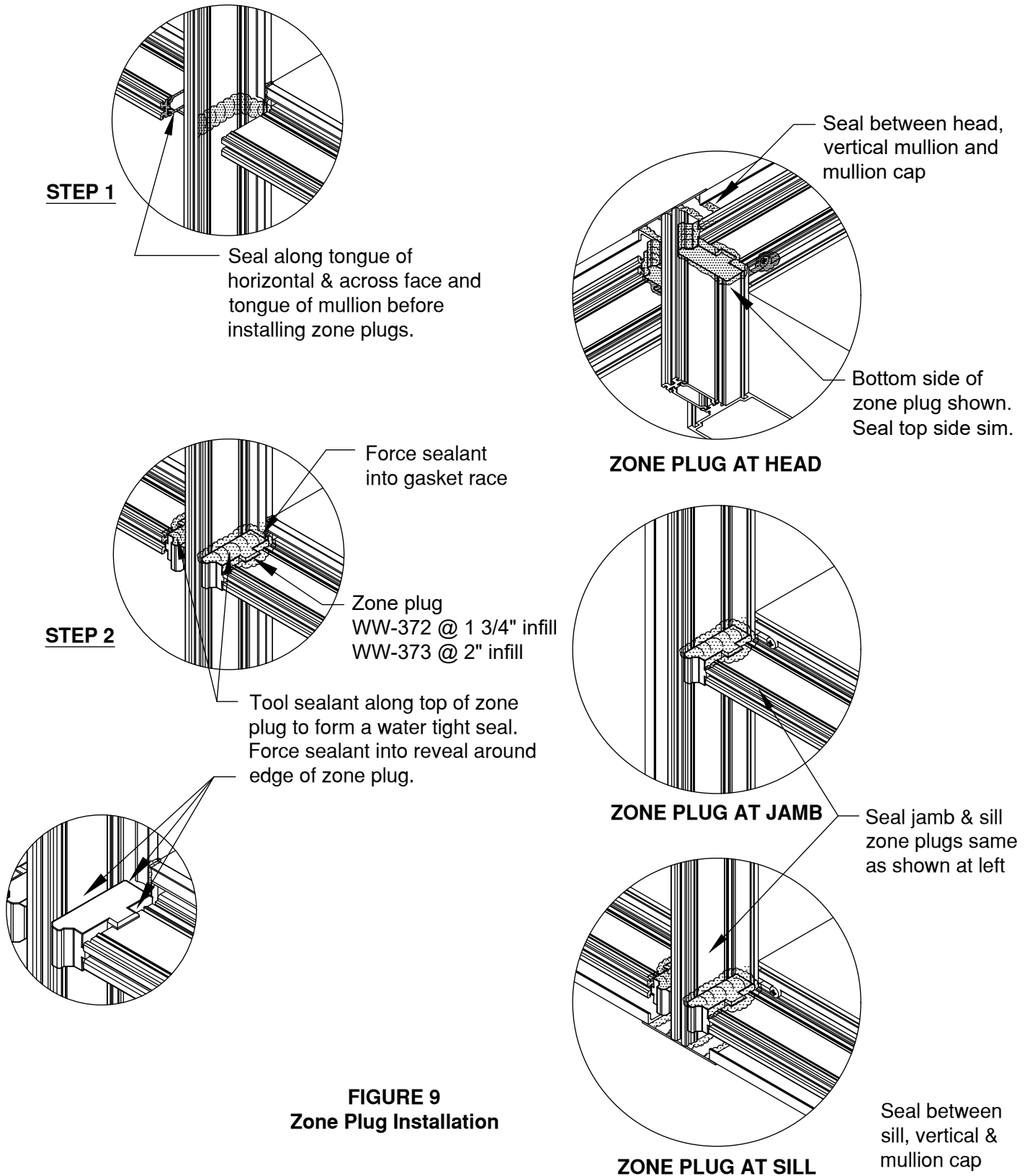

**FIGURE 9**  
**Zone Plug Installation**

# RELIANCE™-HTC INSTALLATION MANUAL

## FRAME INSTALLATION

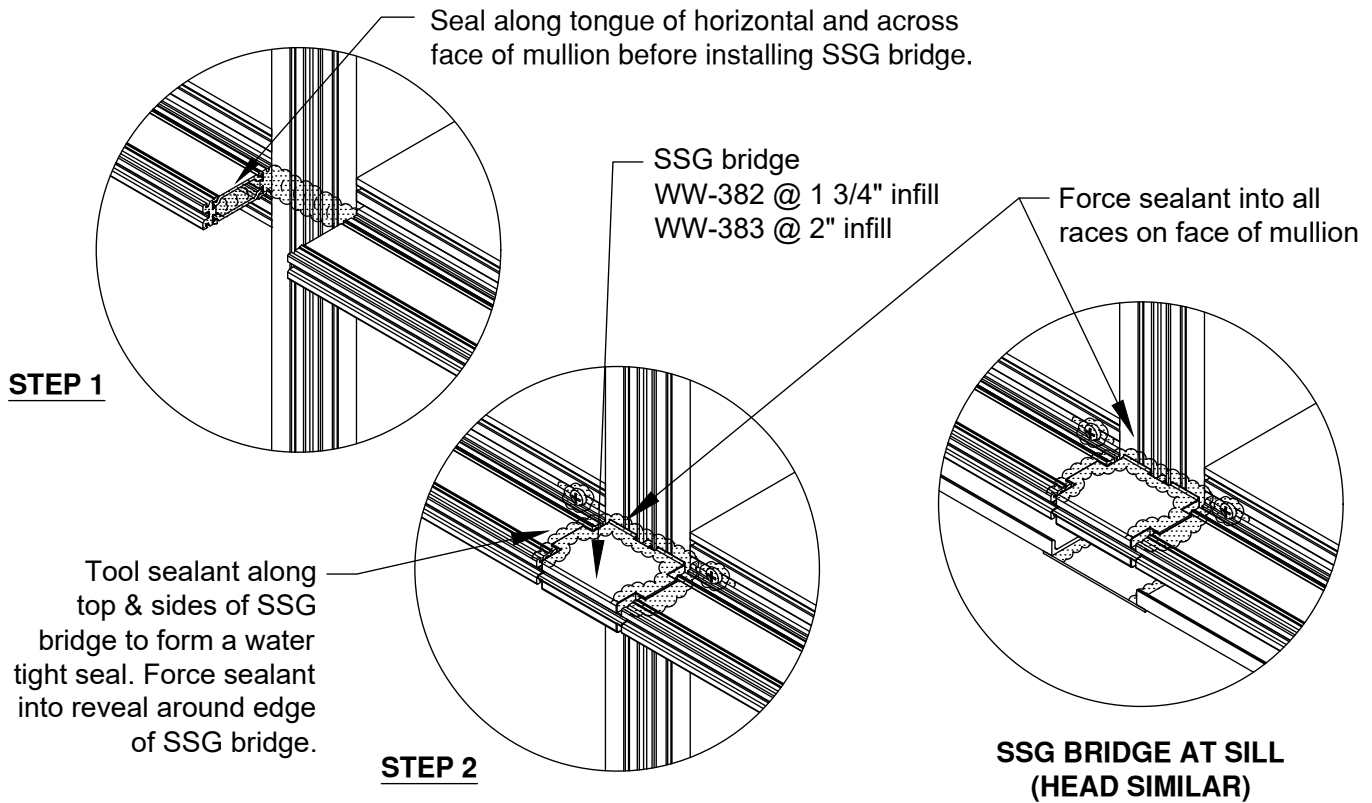

**FIGURE 9 (continued)  
SSG Bridge Installation**

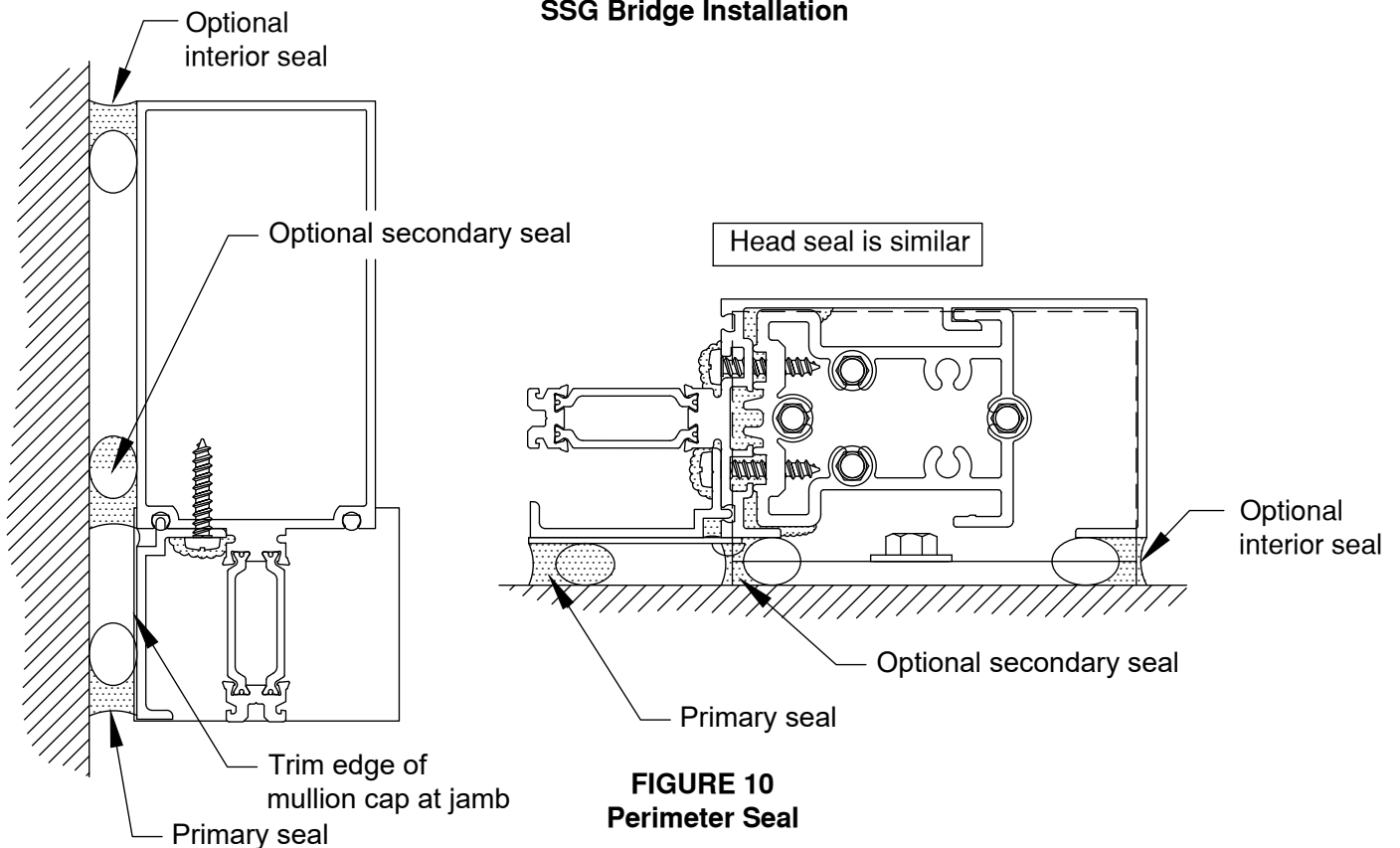

# RELIANCE™-HTC INSTALLATION MANUAL

## GLAZING

### GLASS SIZE CALCULATION FOR TYPICAL CAPTURED & SSG MULLIONS =

D.L.O. plus 1" for WIDTH & HEIGHT at Captured System

D.L.O. plus 2" for WIDTH at SSG System (Verticals Only)

**SEE FIGURE 11** for calculation at one piece corner mullion

**Note:** Steps 3.1 through 3.16 refer to standard glazing of 1 3/4" & 2" infill. For openings requiring transition glazing with adaptors, refer to "TRANSITION GLAZING", page 23.

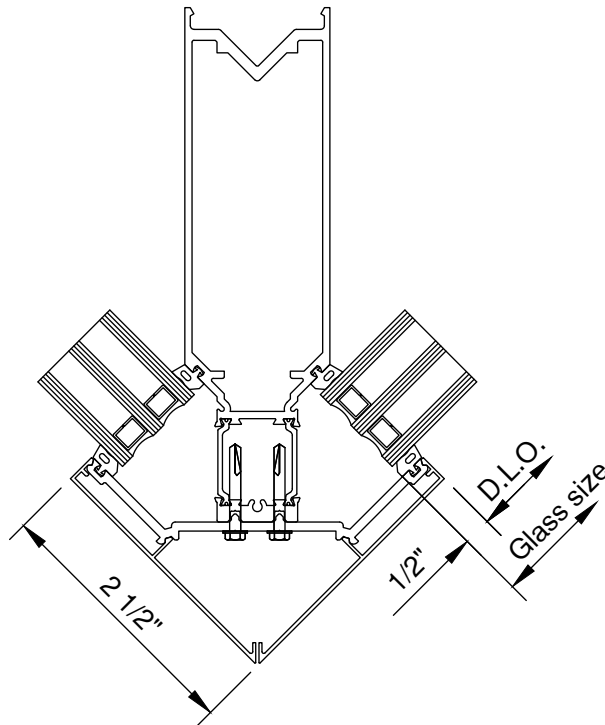

O.S. 90 - Captured  
(1 3/4" Infill Shown; 2" and Spandrel Sim.)

**FIGURE 11**  
**Glass Size Calculation at One Piece Corner**  
**(Dimensions Typ. Both Sides of Corner)**

- 3.1 Install face gaskets into all pressure plates. Install silicone spacer gaskets into the SSG mullions. Crowd all gaskets into members to avoid gaps caused by relaxation of gasket material.
- 3.2 Install thermal spacer into groove on face of mullion tongues. Run through at vertical splice joints. Cut short 1/8" from each end of the mullion. **SEE FIGURE 12.**

# RELIANCE™-HTC INSTALLATION MANUAL

## GLAZING

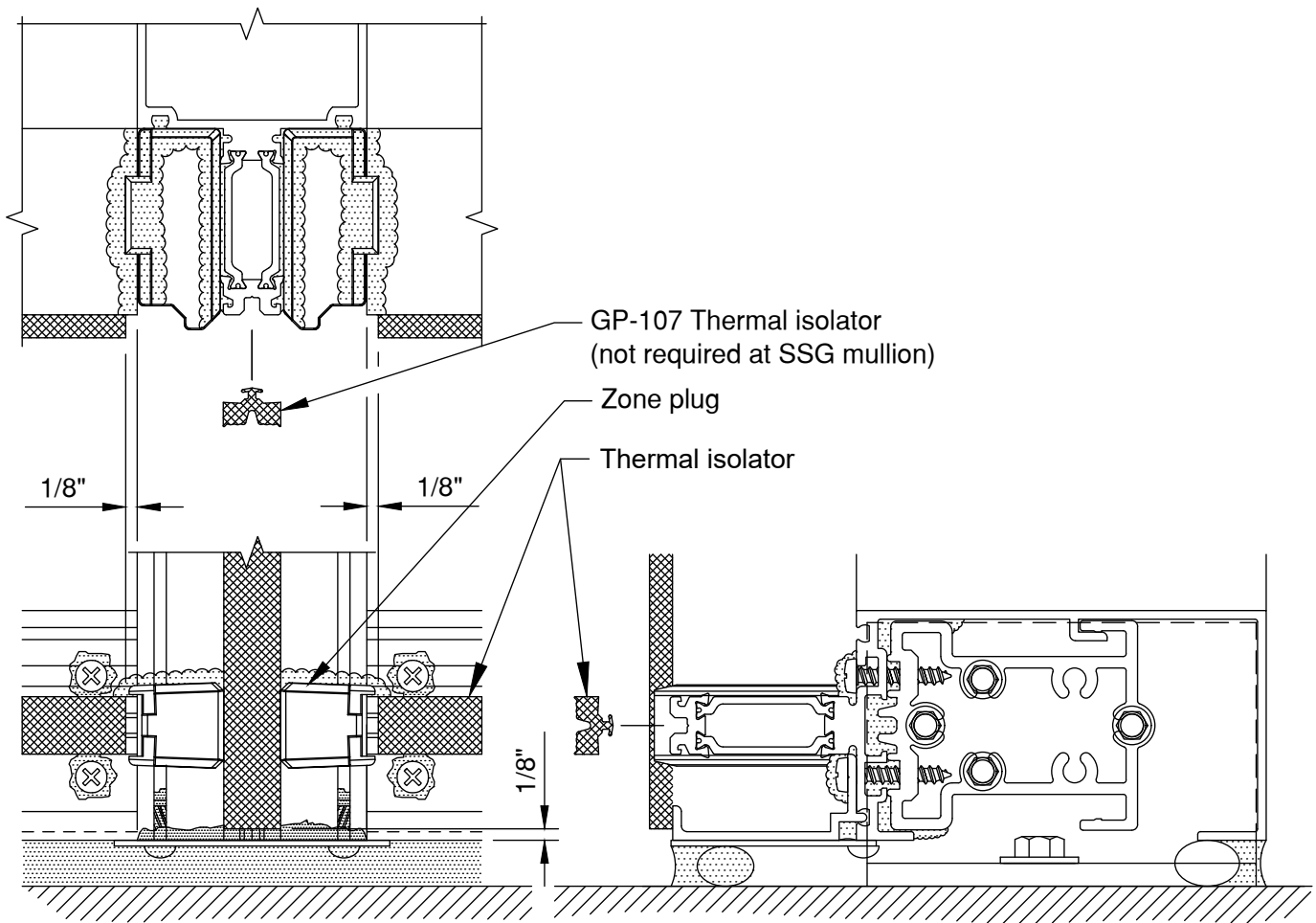

**FIGURE 12**  
**Thermal Isolator Installation**

**3.3 Note:** To avoid silicone curing before glass is set in place and contamination from job-site debris, glazing prep must be done as each opening is glazed. Do not pre-seal the gaskets in the entire frame; seal only the gaskets in the opening for which you are ready to set glass.

- Install interior gaskets into back member (vertical gaskets first). If mullion is spliced, run gasket through the splice joint, setting in fresh silicone at the joint. Trim the gasket dart as required to form an air tight seal. (Glazing gaskets at verticals run through; horizontal gaskets butt into the vertical gaskets.
- Crowd gaskets into corners, cutting horizontal gaskets at a slight angle to conform to the bevel on vertical gaskets.
- Pulling the horizontal gasket back at the ends, seal joint at gasket corners JUST PRIOR TO GLAZING THE OPENING. Release the gasket back to its original position, making sure sealant fills entire joint.
- Tool corner joints after glass is set and temporary glazing retainers are in place.

**NOTE:** Sealant is not required at the horizontal gasket abutting an SSG mullion. This gap will be sealed during application of structural silicone.

**3.4** Position setting blocks at correct location (two per lite). Refer to approved shop drawings or deadload charts. Lubricating the top of setting blocks will help insure proper setting of glass. **Note:** Consult glass manufacturer for correct setting block location and length for glass sizes in excess of 40 sq.ft.

# RELIANCE™-HTC INSTALLATION MANUAL

## GLAZING

- 3.5 Set glass in opening. Ensure that glass bite is equal on all sides. **CAUTION: Be certain that glass is placed firmly against interior gasket to ensure a proper seal and to avoid binding of the glass on the setting block.**
- 3.6 Temporarily hold glass in the opening with WW-333 temporary glazing retainers & FS-325 screw at captured mulls. Use WW-333 retainer with #12-14 x 3" screw for SSG verticals. Torque screws to 60 in-lbs.
- WW-333 temporary glazing retainers must be applied at each glass edge 3" from the corner (minimum of 8 per lite). Glass edges greater than 4' in length but less than 8' require an additional retainer at the glass mid-span. **SEE FIGURES 13 & 14.**
  - Retainers are intended for short term use only. Additional retainers may be required to withstand full design wind load pressures.
  - Full length pressure plates must be installed if severe weather or high wind loads are anticipated.

WW-333-01 temporary glazing retainer. Locate at 3" from edge of glass. Additional clips may be required based on field conditions and glass size.

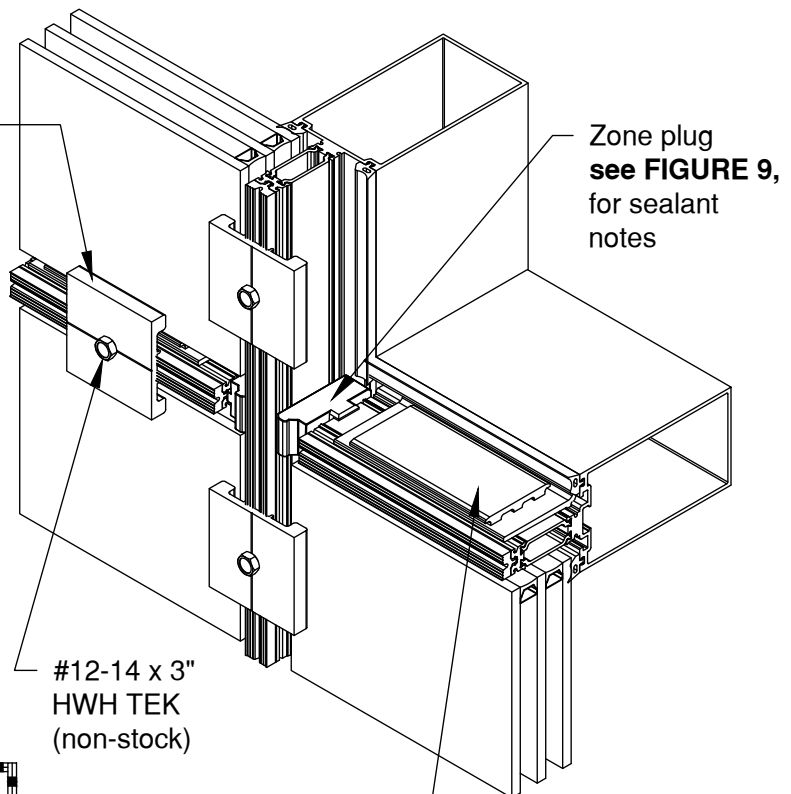

**FIGURE 13**  
Glazing Instructions

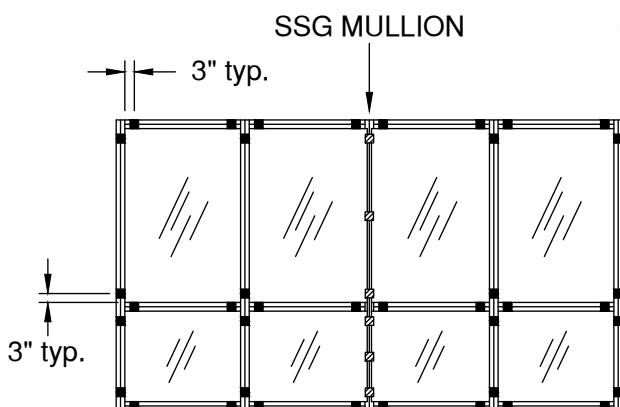

**FIGURE 14**  
Typical Location of  
Temporary Glazing Retainers

# RELIANCE™-HTC INSTALLATION MANUAL

## GLAZING

- 3.7 If required, install GP-111 (1" , 1 3/4" & 2" infill) or GP-112 (1/4" infill) side blocks with silicone at centerline of each lite of glass, along vertical edges, or per approved shop drawings. For framing that will be subjected to seismic events, consult glass manufacturer for preferred location. **NOTE: Side blocks are not required at SSG mullions.**
- 3.8 Repeat steps 3.3 through 3.7 until all glass is set, working row by row up the elevation.

For elevations requiring vertical mullion splices, refer to the **VERTICAL SPLICING** section, pages 25 & 26, before continuing the installation.

- 3.9 Prior to installing vertical pressure plates, apply sealant to the face of each horizontal zone plug. **SEE FIGURE 15.** Vertical pressure plates must be installed before the horizontal pressure plates are applied.

**FS-325 pressure plate fasteners must be located 1 1/2" from horizontal/vertical mullion intersections in order to maintain proper compression on the glass. Drill 7/32" holes in pressure plates as required.**

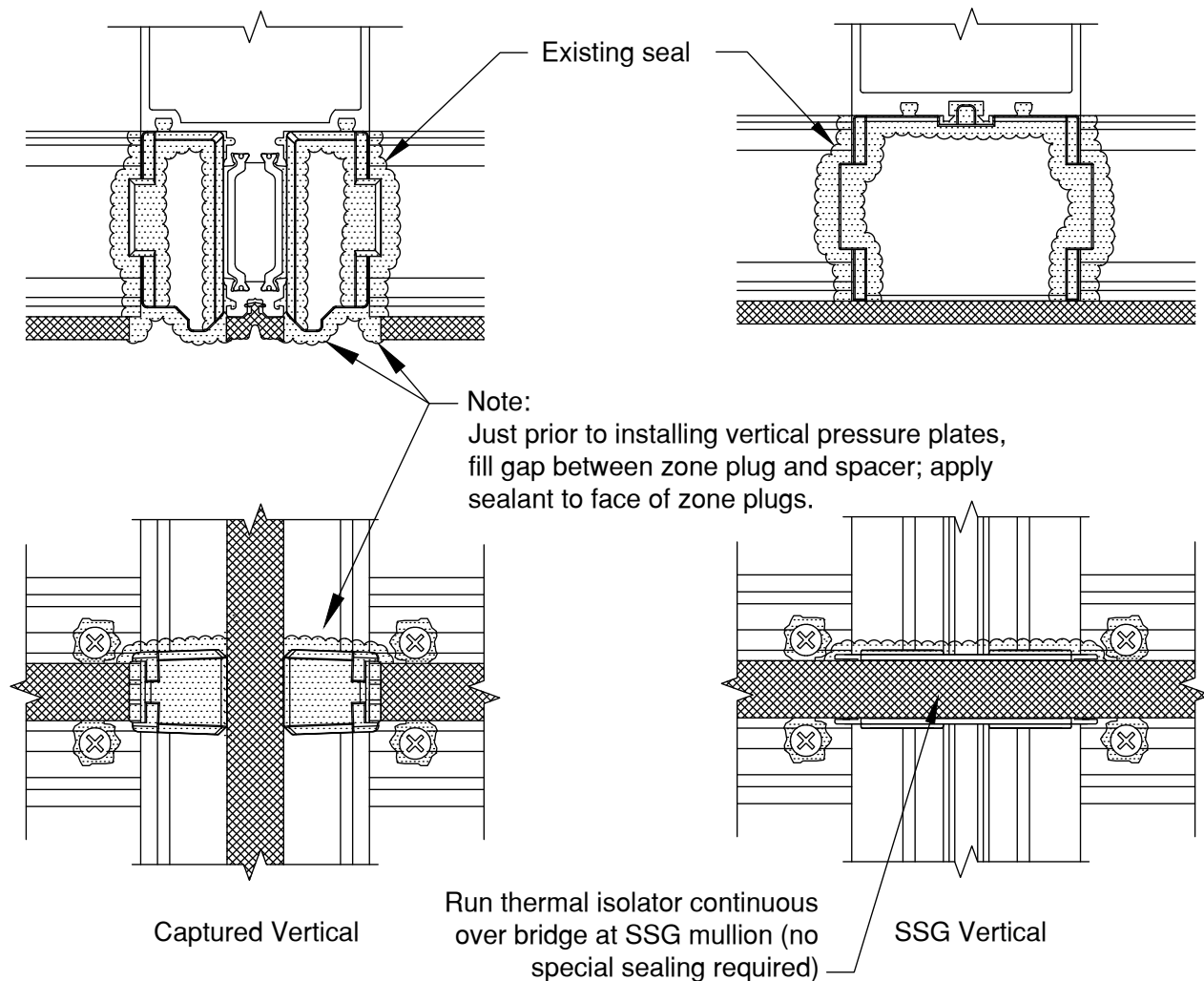

**FIGURE 15**  
**Sealing for Pressure Plates**

# RELIANCE™-HTC INSTALLATION MANUAL

## GLAZING

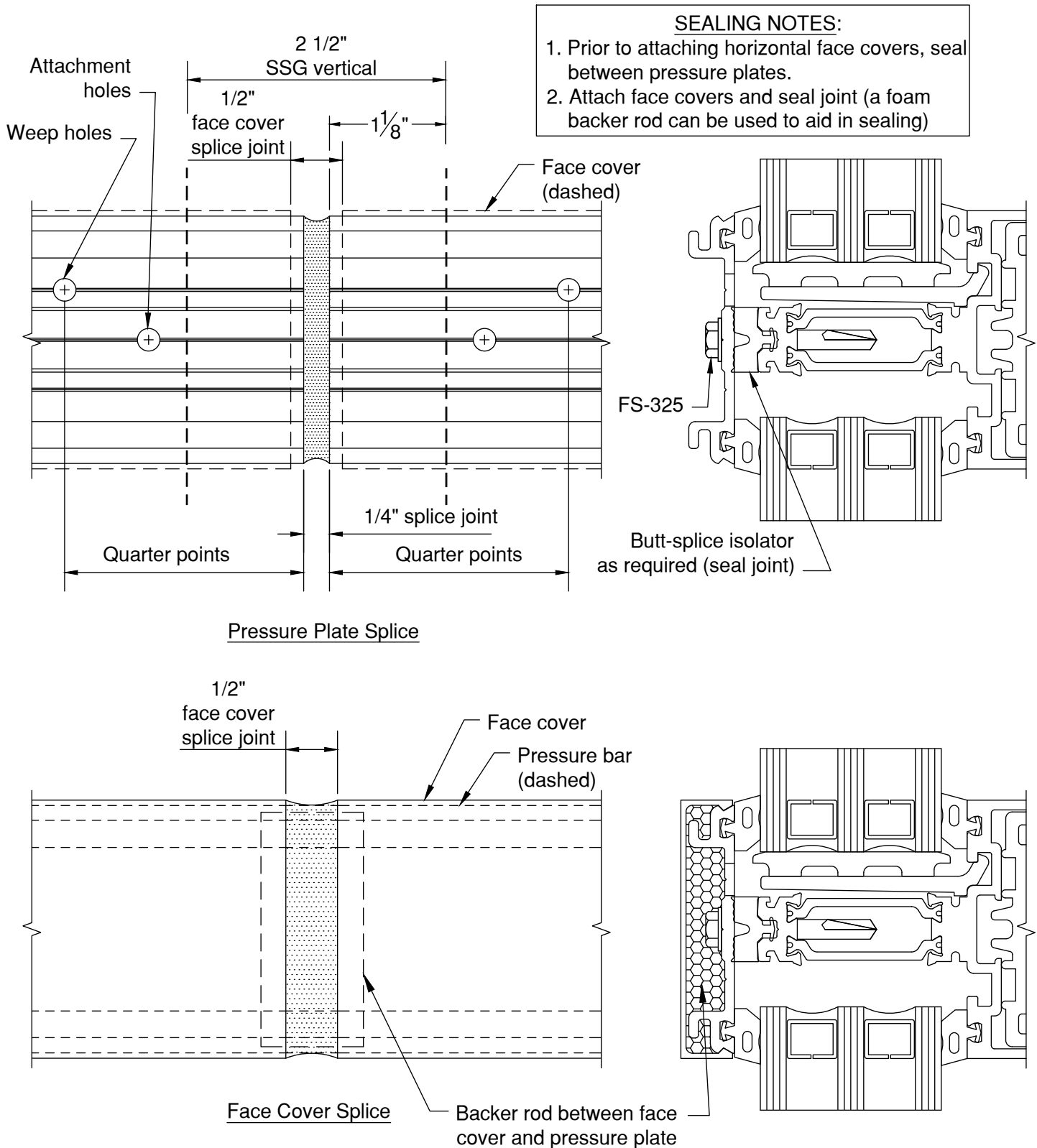
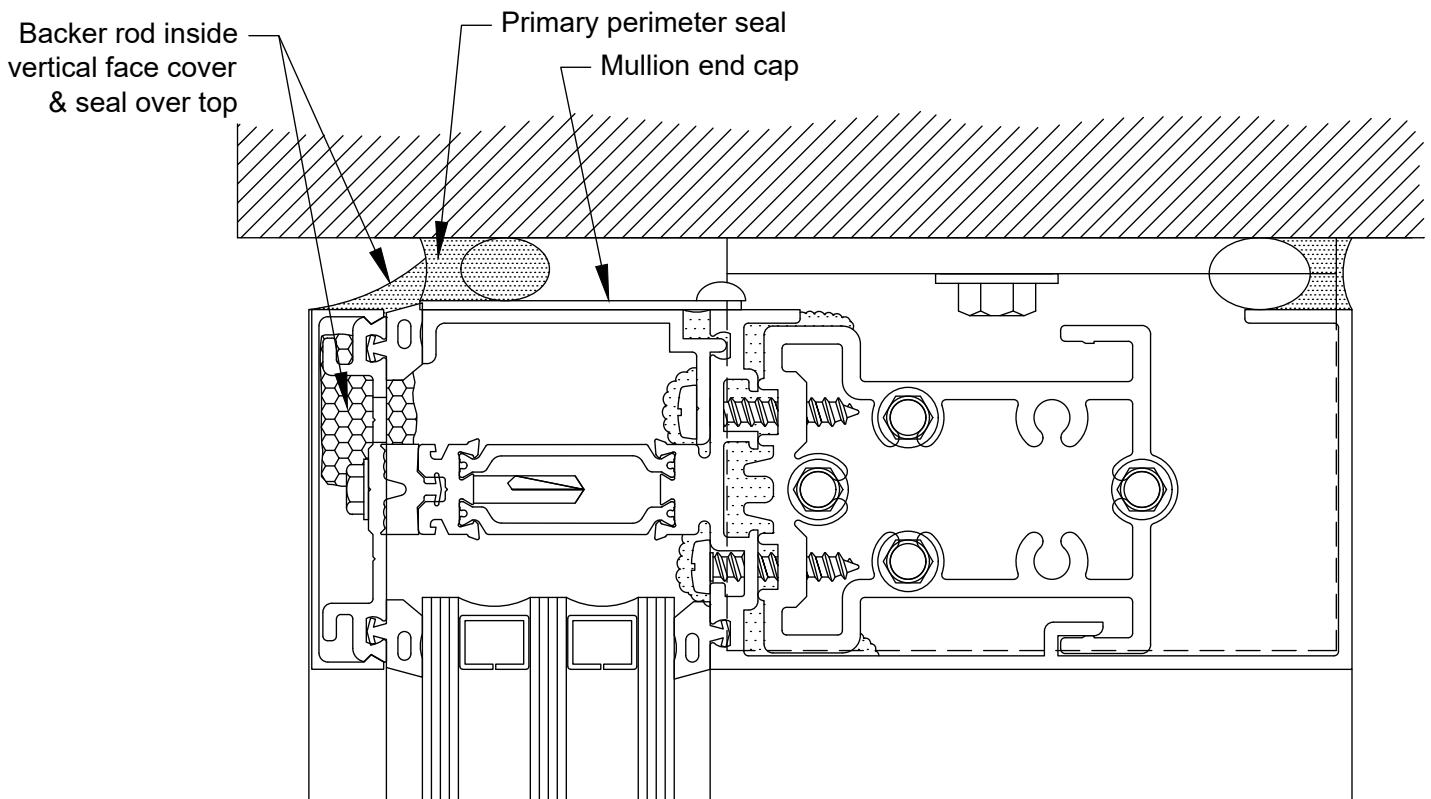

**FIGURE 16**  
**Pressure Plate/Face Cover Splicing & Sealing at SSG Mullions**  
 (Intermediate Horizontal Shown; Head & Sill Similar)

# RELIANCE™-HTC INSTALLATION MANUAL

## GLAZING

- 3.10 After removing vertical temporary retainers, install vertical pressure plates with FS-325 screws at 9" O.C.
- 3.11 After removing horizontal temporary retainers, center horizontal pressure plates in opening, leaving 1/8" gap on each end. Make sure that weep holes are on the top side of the pressure plate. **NOTE: Horizontal pressure plates and face covers run continuous over SSG mullions, not to exceed 3 lites in length. SEE FIGURE 16 for splicing and sealing instructions.**
- 3.12 After all pressure plates are installed on the frame, torque FS-325 screws to 90 in-lbs. The use of either a drill motor with a torque limiter or torque wrench can be used. If using a cordless drill, check torque periodically since battery usage will affect the torque setting.
- 3.13 Install vertical face covers. Using a wood block to protect the cover, apply with dead blow soft face hammer. Pin the vertical face covers once per length as required, concealing pin at a horizontal location.
- 3.14 Insert backer rod into cavity at the top of each vertical mullion. Seal off end of vertical, sloping sealant back to marry with the perimeter seal. **SEE FIGURE 17.**
- 3.15 Seal horizontal pressure plates against the vertical face covers. Tool sealant into the joint. **SEE FIGURE 18.**
- 3.16 Install horizontal face covers, leaving an equal gap at each end. Make sure that the weep hole in the face cover is on the bottom.



**FIGURE 17**  
**Sealing Top of Captured Verticals**

# RELIANCE™-HTC INSTALLATION MANUAL

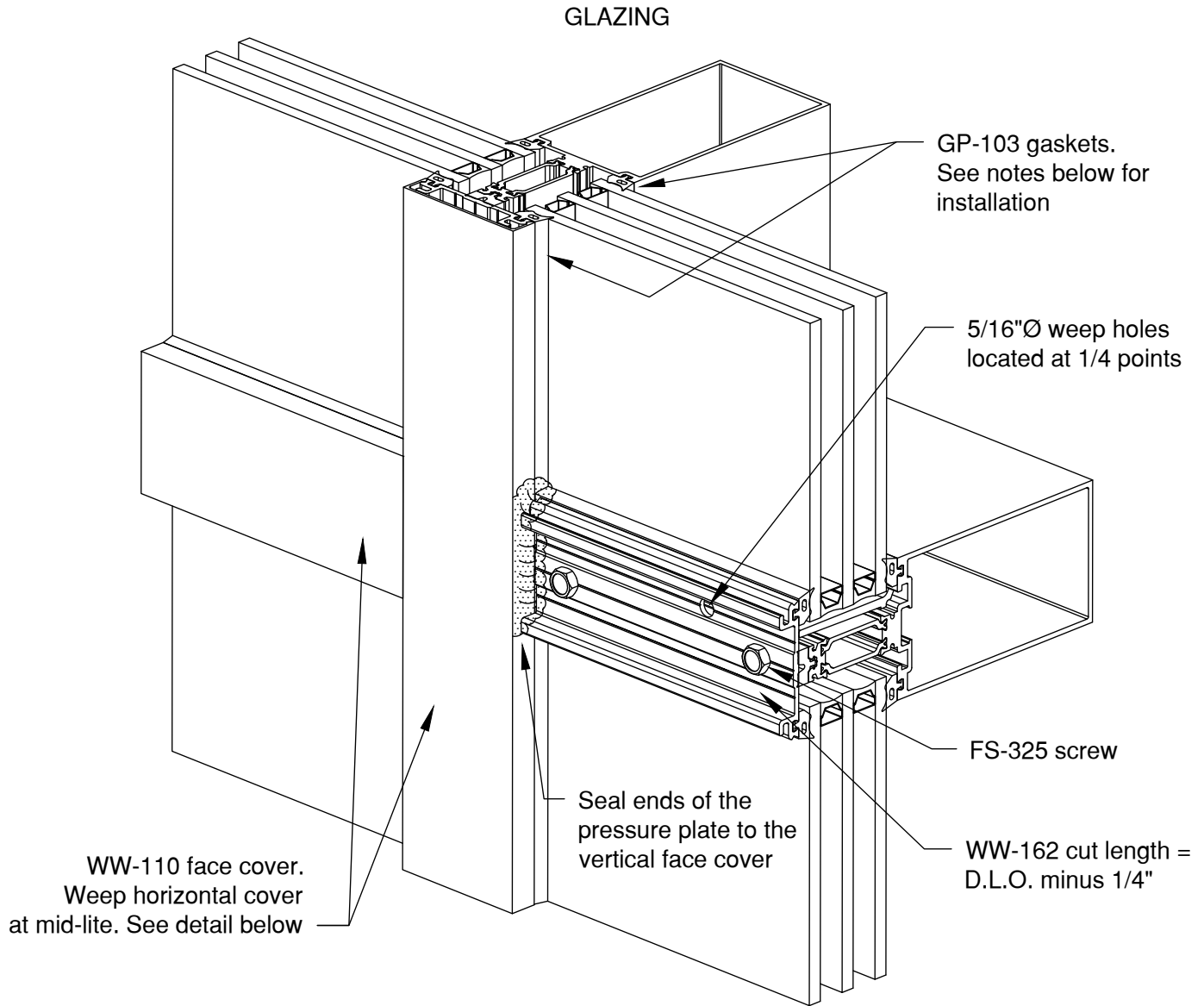

## Glazing Notes:

1. GP-103 dense EPDM gasket used on interior and exterior of system.
2. Remove gaskets from reels and allow to relax overnight before installing.
3. Cut gaskets to allow minimum 1/4" per foot for any relaxation of gasket that may occur after installation.
4. To ensure proper pressure on the glazing, 7/32" diameter holes may need to be drilled at the ends of each horizontal pressure plate as required. locate at 1 1/2" maximum from the ends.

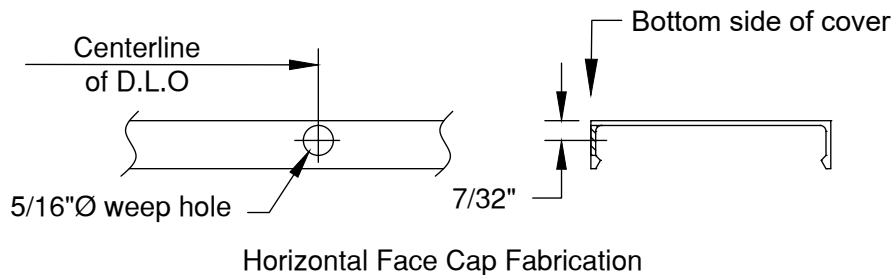
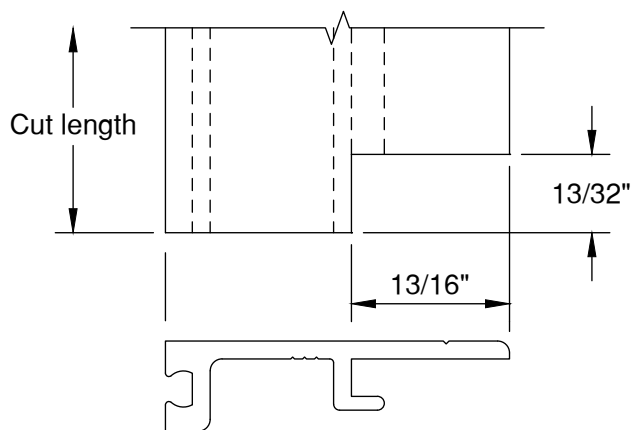

**FIGURE 18**  
**Glazing Instructions**

# RELIANCE™-HTC INSTALLATION MANUAL

## TRANSITION GLAZING

- A.1 Notch vertical adaptors at captured mullions according to **FIGURE 19**. Horizontal adaptors are straight cut. Install vertical adaptors first, leaving an equal overlap into each pocket. Refer to **VERTICAL SPLICING, page 25 & 26** if vertical mullion is spliced within a spandrel lite. Transition adaptors must be installed after mullion splice is sealed.
- A.2 For SSG mullions, install locator leg into one of the glazing reglets. Secure to mullion with FS-149 (#12 x 3" PFH SMS) for 1/4" spandrel glazing and FS-318 (#12 x 1-3/4" PFM SMS) for 1" spandrel infill. Attach @ 12" O.C. **SEE FIGURE 20**.
- A.3 Install horizontal adaptors maintaining an equal gap at each end. Once all adaptors have been installed in the opening, seal all joints between the vertical and horizontal adaptors as well as screw heads. **SEE FIGURE 21**.



**FIGURE 19**  
**Notch at Vertical Adaptors**  
(adaptor for 1/4" infill shown; 1" similar)

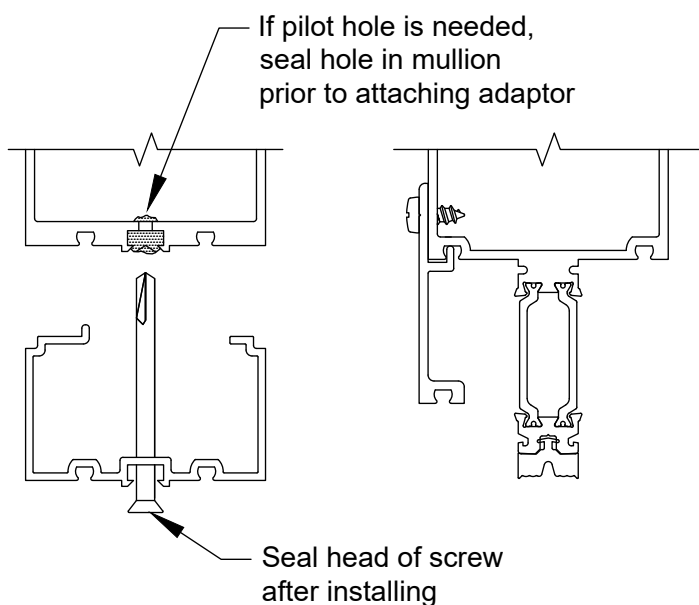

**FIGURE 20**  
**Installing Glazing Adaptors**

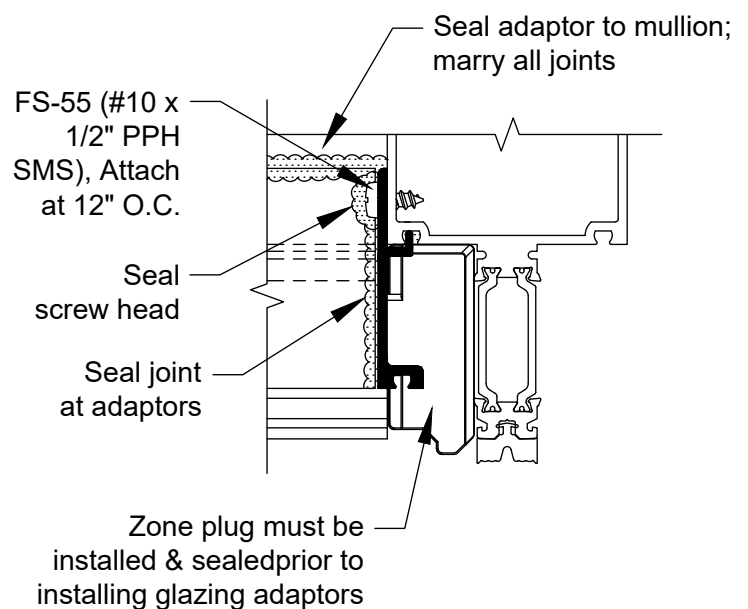
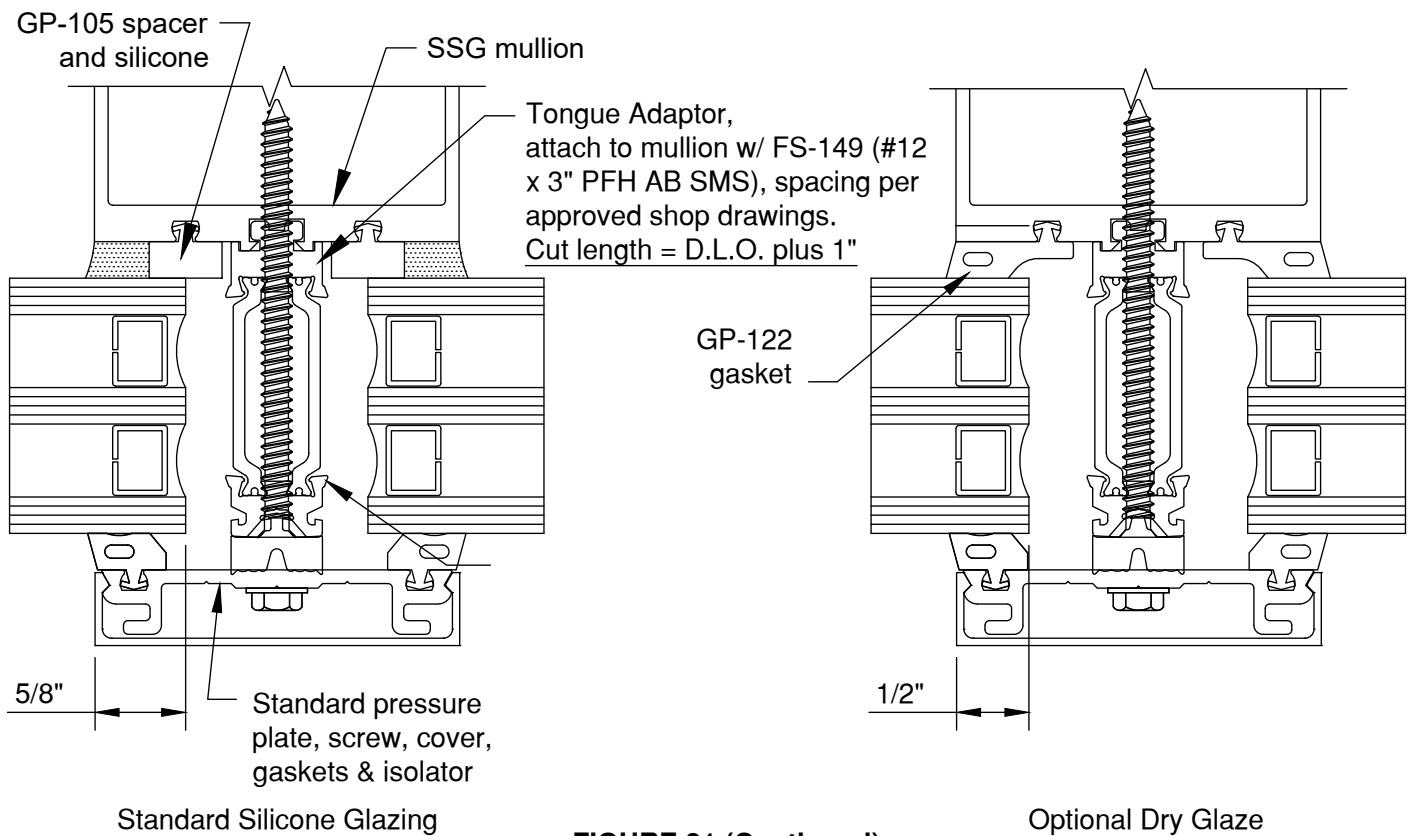

**FIGURE 21**  
**Sealing Glazing Adaptors**

# RELIANCE™-HTC INSTALLATION MANUAL

## TRANSITION GLAZING

**\* Note : AW-125 (for 1 3/4" infill) and AW-126 (for 2" infill) tongue adaptor must be slid in place and fastened to mullion prior to erecting the mullion.**



**FIGURE 21 (Continued)  
Glazing Adaptors**

Captured Glazing Adaptor for SSG Mullion

## VERTICAL SPLICING

Refer to **MULTI-SPAN INSTALLATION**, page 12 for splice sleeve installation.

Follow sealant manufacturer's guidelines for proper joint width based on anticipated movement. A minimum 1/2" joint is recommended. **Note: Standard splice joints are engineered to accommodate thermal expansion only. They do not allow for movement in floor levels.** Refer to approved shop drawings for special circumstances, or contact your nearest **Oldcastle BuildingEnvelope™** facility.

- B.1 Apply bond breaker tape to the face of splice sleeves, returning back on the sides 1" minimum. Insert backer rod into the hollow of the vertical mullion, top and bottom. Seal between top and bottom mullion from the front of the tongue to 1" behind glass pocket. Follow the contour of the glazing reglets with the sealant to insure a good seal when gaskets are installed. **SEE FIGURE 7.**
- B.2 Discontinue glazing adaptors at splice joints. Install backer rod into cavity and seal between adaptors. Marry adaptor seal with main mullion seal. Refer to step B.1 above for sealing notes at glazing reglets.
- B.3 Offset pressure plates and face covers per **FIGURE 22**, sealing pressure plate and face cover joints as shown in **FIGURE 23.**

# RELIANCE™-HTC INSTALLATION MANUAL

## VERTICAL SPLICING

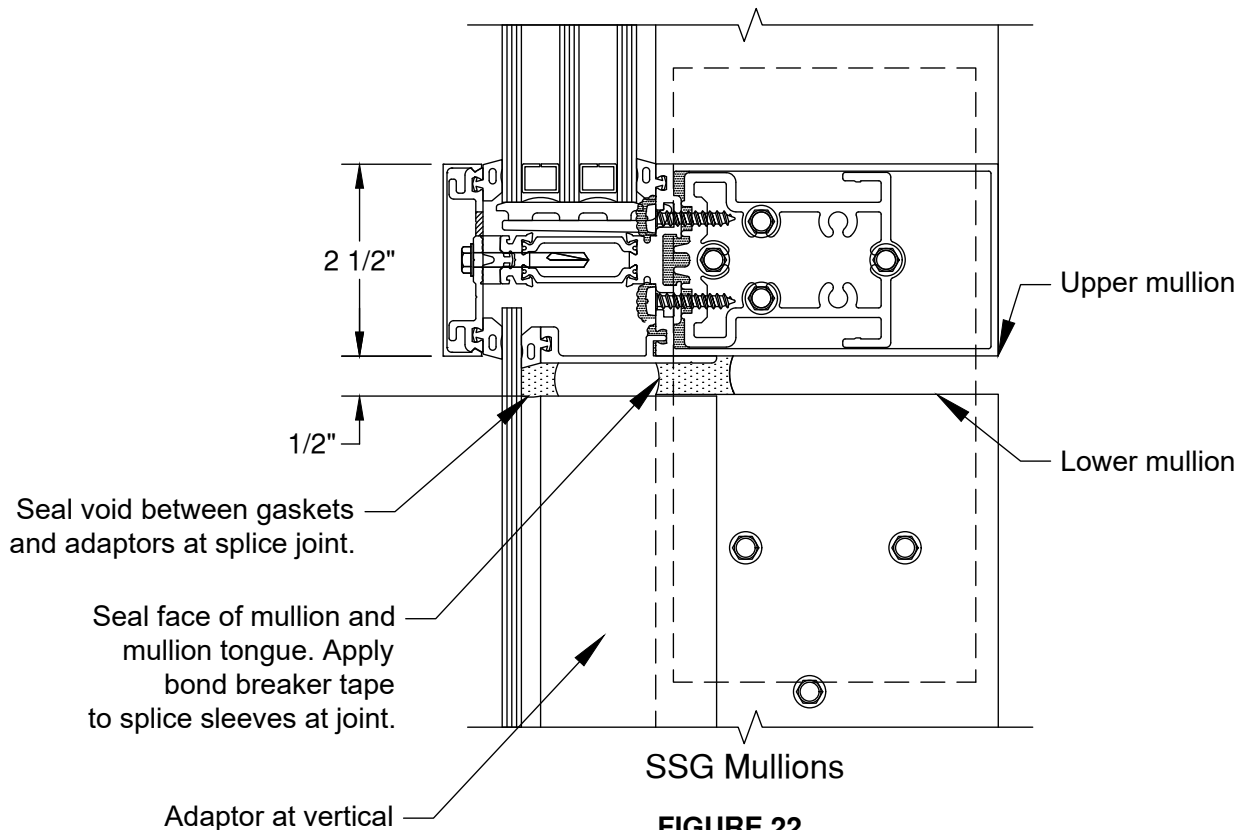
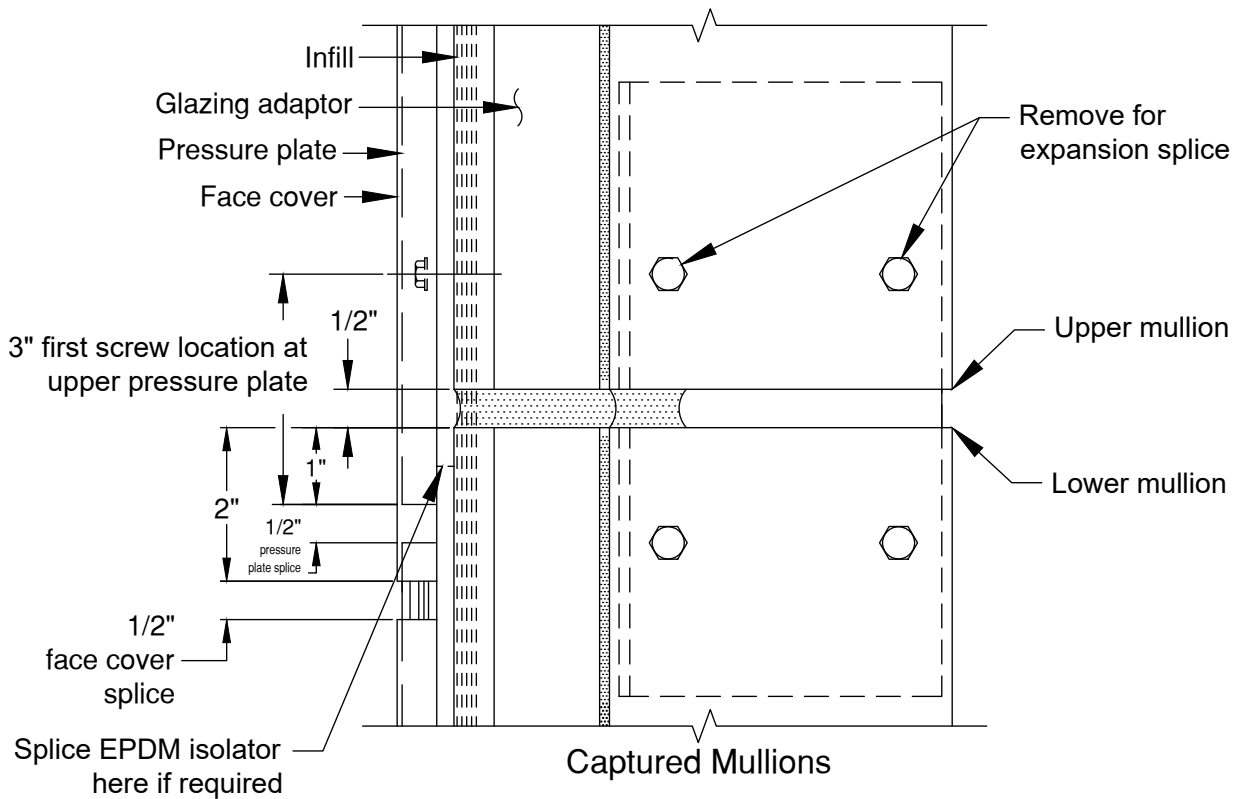

**FIGURE 22**  
**Vertical Mullion Splice**  
 (See FIGURE 7, page 12 for Splice Installation)

# RELIANCE™-HTC INSTALLATION MANUAL

## VERTICAL SPLICING

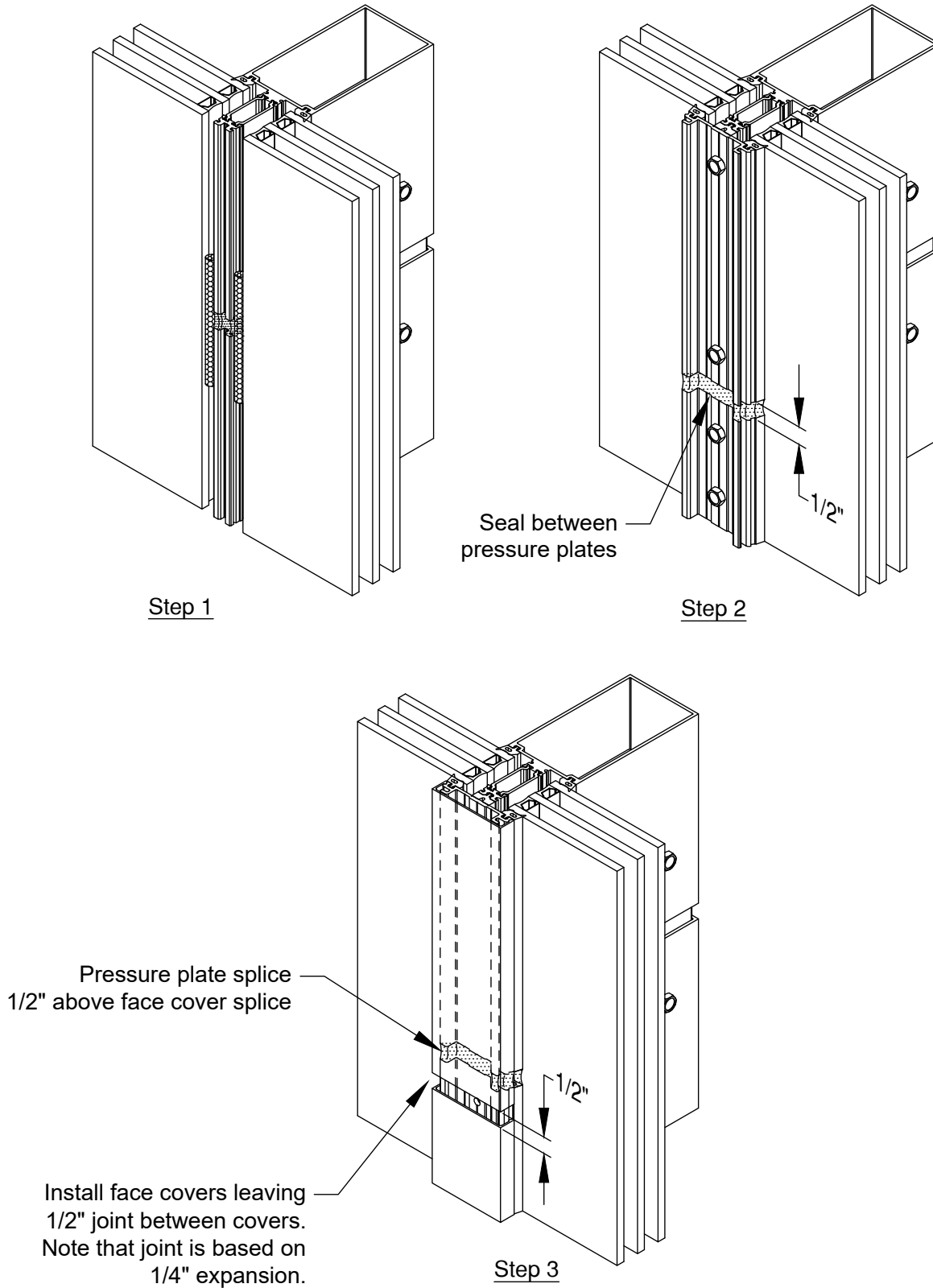

**FIGURE 23**  
**Splice Joint Sealing Instructions**

# RELIANCE™-HTC INSTALLATION MANUAL

## ENTRANCE FRAMES

All door framing components are shipped fabricated from the factory. The main curtain wall framing can be erected prior to installing the doors.

C.1 Curtain wall verticals and door subframes run through to finished floor. Bed adjacent curtain wall verticals in sealant and anchor to floor per approved shop drawings. **SEE FIGURE 26** for suggestions on anchoring door jamb mullion.

### C.2 SUBFRAME INSTALLATION:

C.2.1 Attach threshold clip to bottom of each jamb subframe with screws provided.

C.2.2 Install pocket filler onto curtain wall mullion. **SEE FIGURE 24.**

C.2.3 Bed subframes in sealant. Anchor to curtain wall framing members with FS-322 #12 x 1" HH STS at 18" O.C. Seal joint between jamb and header subframes. Seal tops of the jamb subframes. **SEE FIGURE 25.**

C.2.4 Bed threshold in sealant, attaching to threshold clips with screws provided. Marry threshold seal with subframe and main system seal. **SEE FIGURE 25.**

C.2.5 Install door stops in subframe. The vertical stops run through.

C.2.6 Install pressure plates and face covers per standard installation instructions.

C.2.7 Install door per DOOR & FRAME INSTALLATION & GLAZING MANUAL.

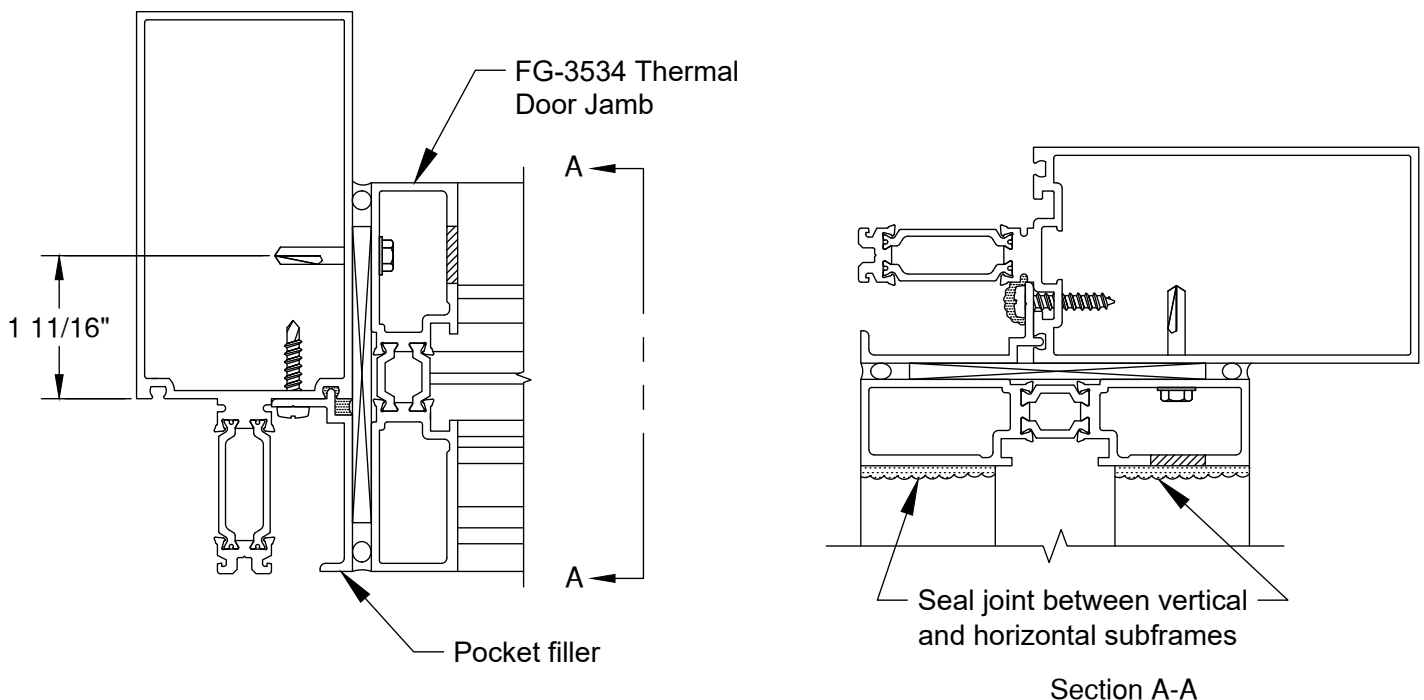

**FIGURE 24**  
**Attaching Subframes**

# RELIANCE™-HTC INSTALLATION MANUAL

## ENTRANCE FRAMES

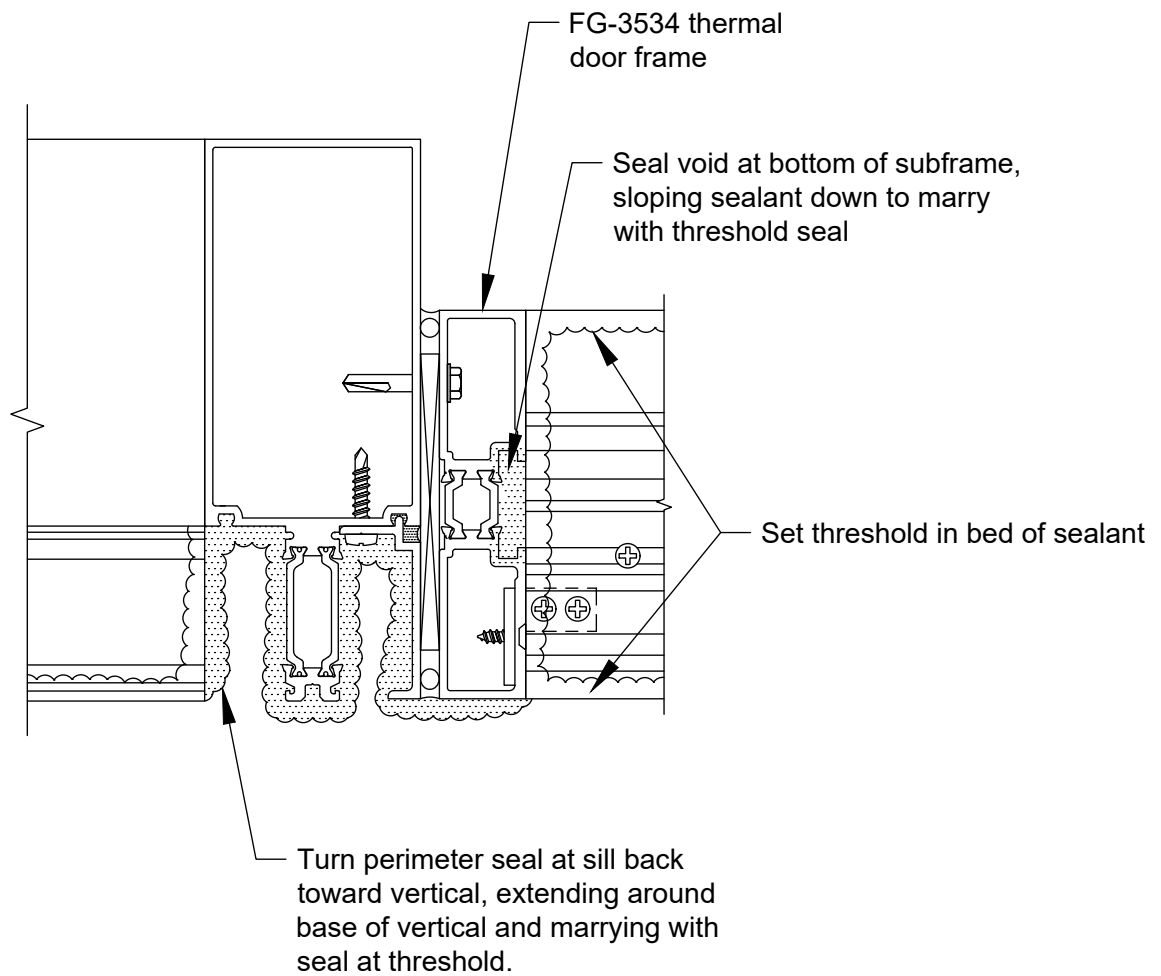

**FIGURE 25**  
**Sealing Verticals at Entrance Doors**

# RELIANCE™-HTC INSTALLATION MANUAL

## ENTRANCE FRAMES

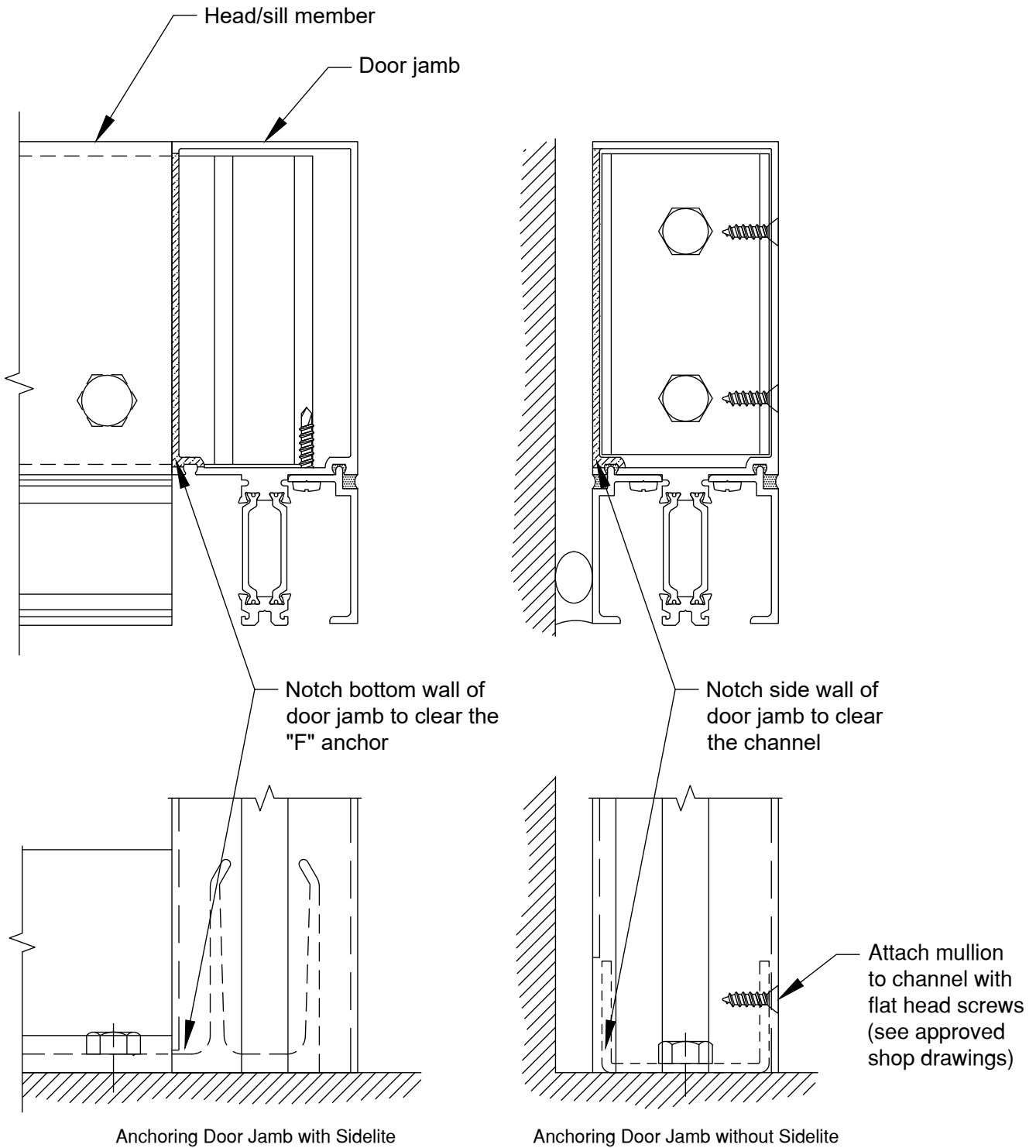
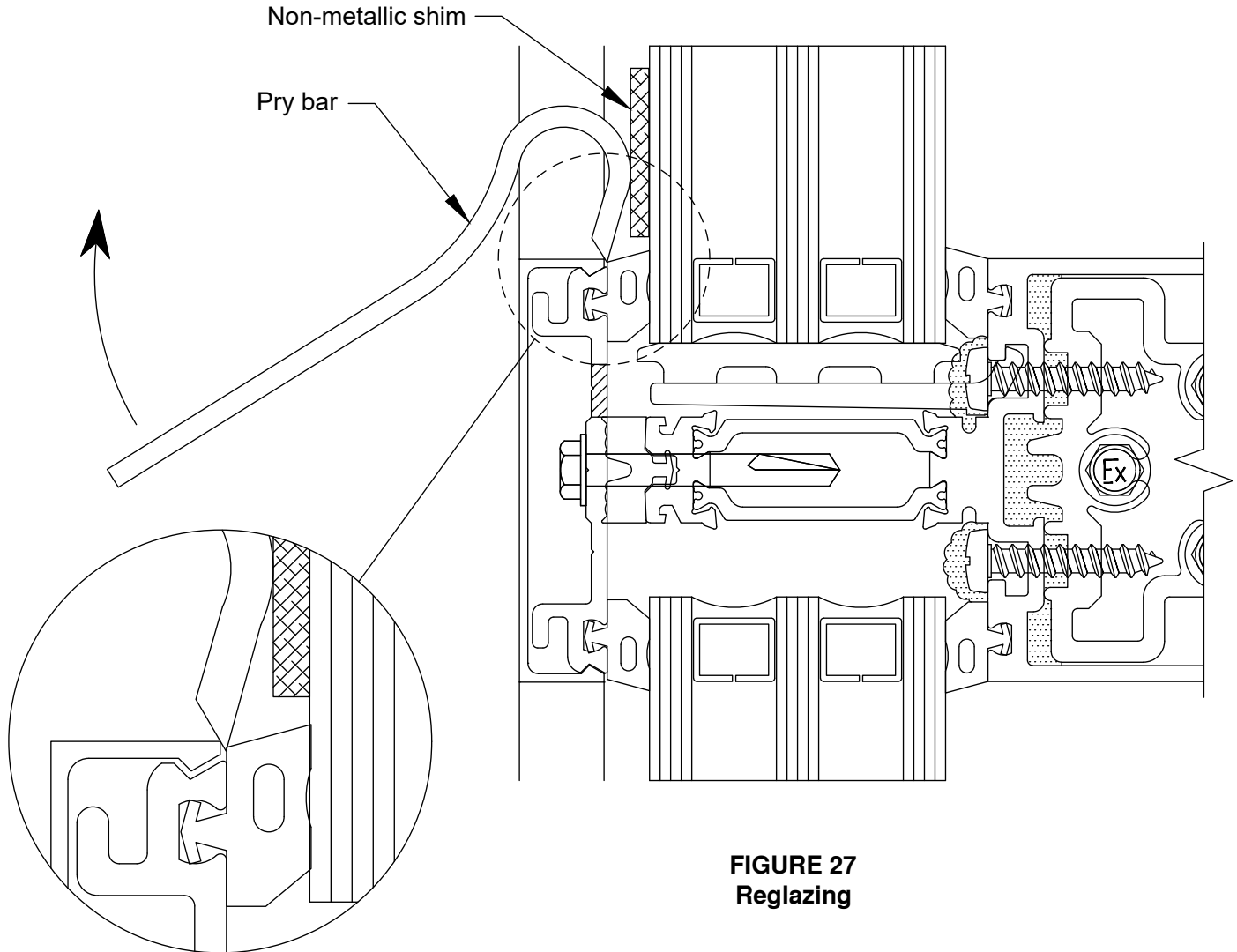

**FIGURE 26**  
**Anchoring Door Jamb Mullions**

# RELIANCE™-HTC INSTALLATION MANUAL

## REGLAZING PROCEDURES

- E.1 Reglazing must be done from the exterior. carefully remove face covers surrounding the lite of glass to be deglazed. **SEE FIGURE 27.**



**FIGURE 27**  
**Reglazing**

- E.2 Remove vertical and horizontal pressure plates adjacent to lite that must be replaced. Temp surrounding glass in place with WW-333 temporary glazing retainers. torque to 60 in-lbs. refer to step 3.6, page 18 for instructions on locating retainers.
- E.3 Remove lite of glass and existing gaskets from opening. Clean debris and sealant from aluminum framing members and pressure plates.
- E.4 Install new gaskets into framing and install new lite of glass. See glazing section of this manual for proper procedure.
- E.5 Reinstall pressure plates and seals per glazing section of this manual.

# RELIANCE™-HTC INSTALLATION MANUAL

## CORNER MULLION

**FIGURE 28** shows the basic layout of the standard one-piece corner mullion assembly. These details are for general reference and do not necessarily reflect all conditions. For specific assembly, sealing and anchoring notes, refer to approved shop drawings. See Parts List for specific part numbers.

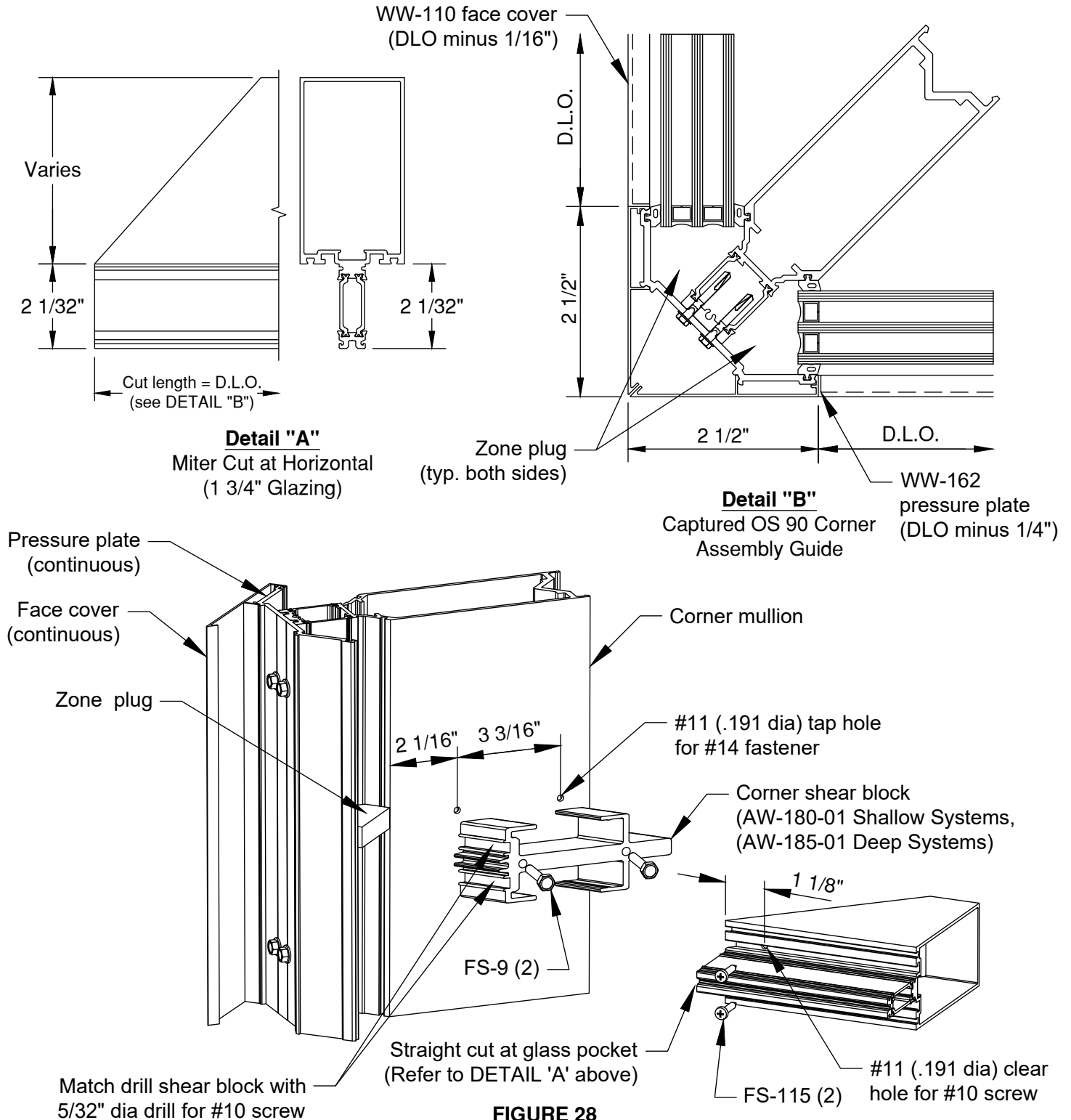
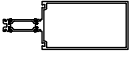
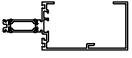

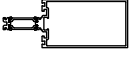

**FIGURE 28**  
Captured OS 90 Corner Assembly  
(Cut lengths in parentheses)



# RELIANCE™-HTC INSTALLATION MANUAL

## PARTS LIST



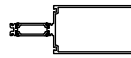
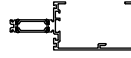

### 7 1/4" SYSTEM, 1 3/4" GLAZING

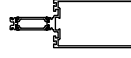
 AW-500	Vertical & Jamb
 AW-501	Head & Sill
 AW-504	SSG Mullion
 AW-505	Horizontal



### 7 1/2" SYSTEM, 2" GLAZING

 AW-550	Vertical & Jamb
 AW-551	Head & Sill
 AW-504	SSG Mullion
 AW-555	Horizontal

### 10" SYSTEM, 1 3/4" GLAZING

 AW-800	Vertical & Jamb
 AW-801	Head & Sill
 AW-804	SSG Mullion
 AW-805	Horizontal

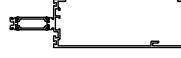









### 10 1/4" SYSTEM, 2" GLAZING

 AW-850	Vertical & Jamb
 AW-851	Head & Sill
 AW-804	SSG Mullion
 AW-855	Horizontal



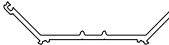

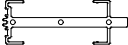



# RELIANCE™-HTC INSTALLATION MANUAL

## PARTS LIST

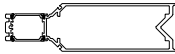
### CORNER MULLIONS & ACCESSORIES

	Face Cover 90° OS Captured 1 3/4" Infill
AW-115	
	Face Cover 90° OS Captured 2" Infill
AW-117	
	Glazing Adaptor 90° OS Captured 1 3/4" to 1/4" Infill
AW-140	
	Glazing Adaptor 90° OS Captured 1 3/4" to 1" Infill
AW-141	
	Glazing Adaptor 90° OS Captured 2" to 1/4" Infill
AW-142	
	Glazing Adaptor 90° OS Captured 2" to 1" Infill
AW-143	
	Pressure Plate 90° OS Captured 1 3/4" Infill
AW-171	
	Pressure Plate 90° OS Captured 2" Infill
AW-172	
	Shear Block 90° Corner Mullions 7 1/4" & 7 1/2" Depths
AW-180-01	
	Shear Block 90° Corner Mullions 10" & 10 1/4" Depths
AW-185-01	
	Splice Sleeve at Corners Use with AW-240, AW-241, AW-250, AW-251
AW-198-01	

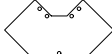
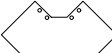
### CORNER MULLIONS & ACCESSORIES

	Splice Sleeve at Corners Use with AW-250, AW-251
AW-198-02	
	90° OS Captured 1 3/4" Infill 7 1/4" Depth
AW-240	
	90° OS Captured 2" Infill 7 1/2" Depth
AW-241	
	90° OS Captured 1 3/4" Infill 10" Depth
AW-250	
	90° OS Captured 2" Infill 10 1/4" Depth
AW-251	
	Foam Zone Plug 90° OS Captured 2" Infill
AW-307	
	Foam Zone Plug 90° OS Captured 1 3/4" Infill
AW-308	
	Mullion Cap 90° OS Captured & SSG 1 3/4" Infill
AW-390	
	Mullion Cap 90° OS Captured & SSG 2" Infill
AW-395	
	Snap-In Back Trim Use with Corner Mullions
CW-823	
	T-Anchor at Corners Use with AW-240, AW-241, AW-245, AW-246
WW-102-18	









# RELIANCE™-HTC INSTALLATION MANUAL

## PARTS LIST







### CORNER MULLIONS & ACCESSORIES

 WW-102-19	T-Anchor at Corners Use with AW-250, AW-251, AW-255, AW-256
------------------------------------------------------------------------------------------------	----------------------------------------------------------------------



### COMMON EXTRUSIONS

 AW-121-01	Setting Chair 1 3/4" Infill
 AW-122	Pocket Filler 1 3/4" Infill (use with exterior gasket)
 AW-123-01	Setting Chair 2" Infill
 AW-124	Pocket Filler 2" Infill (use with exterior gasket)
 AW-125	Glazing Adaptor SSG to Captured 1 3/4" Infill
 AW-126	Glazing Adaptor SSG to Captured 2" Infill
 AW-130	Glazing Adaptor Captured Vertical & Horizontal 1 3/4" to 1/4" Infill
 AW-131	Glazing Adaptor SSG Vertical 1 3/4" to 1/4" Infill
 AW-132	Glazing Adaptor Captured Vertical & Horizontal 1 3/4" to 1" Infill

### COMMON EXTRUSIONS

 AW-133	Glazing Adaptor SSG Vertical 1 3/4" to 1" Infill
 AW-135	Glazing Adaptor Captured Vertical & Horizontal 2" to 1/4" Infill
 AW-136	Glazing Adaptor SSG Vertical 2" to 1/4" Infill
 AW-137	Glazing Adaptor Captured Vertical & Horizontal 2" to 1" Infill
 AW-138	Glazing Adaptor SSG Vertical 2" to 1" Infill
 WW-110	Face Cover Horizontal & Vertical
 WW-162	Pressure Plate Horizontal & Vertical











### STANDARD ACCESSORIES

 AW-181-01	Shear Block 7 1/4" & 7 1/2" Depths
 AW-182-01	Shear Block 10" & 10 1/4" Depths
 AW-194-01	Splice Sleeve Use with AW-500 & AW-550



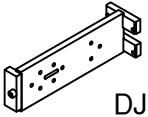



# RELIANCE™-HTC INSTALLATION MANUAL

## PARTS LIST

### STANDARD ACCESSORIES

 AW-195-01	Splice Sleeve Use with AW-504
 AW-196-01	Splice Sleeve Use with AW-800 & AW-850
 AW-197-01	Splice Sleeve Use with AW-804
 AW-370	Captured Mullion Cap Intermediates & Jambes 1 3/4" Infill
 AW-375	SSG Mullion Cap Intermediates & Jambes 1 3/4" Infill
 AW-380	Captured Mullion Cap Intermediates & Jambes 2" Infill
 AW-385	SSG Mullion Cap Intermediates & Jambes 2" Infill
 DJ-113	Drill Jig Verticals & Horizontals
 FS-9	#14 x 1 1/2" Hex Head Shear Block to Vertical
 FS-13	#10 x 1" Phillips PH TEK Pocket Fillers
 FS-55	#10 x 1/2" Phillips RH Captured Glazing Adaptors











### STANDARD ACCESSORIES

 FS-115	#10 x 1" Phillips Pan Head Horizontal to Shear Block
 FS-149	#12 x 3" Phillips FH SMS, Attaches AW-125, AW-126 (SSG Transition Tongue Adaptors), AW-131, & AW-136 (SSG Spandrel Adaptors)
 FS-318	#12 x 1-3/4" Phillips FH SMS, Attaches AW-133 & AW-138 SSG Spandrel Adaptors
 FS-320	M4 x 16mm Drive Pin All Mullion Caps
 FS-322	#12-14 x 1" HWH TEK Splice Sleeves
 FS-325	#12-24 x 1 11/32" HWH Pressure Plate to Vertical & Temp Glazing Retainer (Captured Mulls)
 Non-Stock	#12-14 x 3" HWH TEK Temp Glazing Retainer (SSG Mulls)



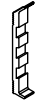







# RELIANCE™-HTC INSTALLATION MANUAL

## PARTS LIST

### STANDARD ACCESSORIES

	GP-103	Standard Dense Gasket Interior & Exterior 1/4" Face Clearance
	GP-104	Optional Sponge Gasket Interior Only 1/4" Face Clearance
	GP-105	Standard Spacer Gasket SSG Vertical Mullions 3/8" Silicone Joint Width
	GP-106	Optional Spacer Gasket SSG Vertical Mullions 1/2" Silicone Joint Width
	GP-107	Thermal Isolator
	GP-111	Side Block 1", 1 3/4" & 2" Infills
	GP-112	Side Block 1/4" Infill
	GP-117	Optional Dense Gasket 3/16" Face Clearance
	GP-118	Optional Dense Gasket 5/16" Face Clearance
	GP-175	Setting Block 1 3/4" Infill
	GP-1003	Setting Block 2" Infill



### STANDARD ACCESSORIES

	HP-1004	Optional Weep Baffle
	WW-102-16	Intermediate "T" Anchor Use with AW-500 & AW-550
	WW-102-17	Intermediate "T" Anchor Use with AW-504
	WW-102-20	Intermediate "T" Anchor Use with AW-800 & AW-850
	WW-102-21	Intermediate "T" Anchor Use with AW-804
	WW-103-11	Jamb "F" Anchor Use with AW-500 & AW-550
	WW-103-12	Jamb "F" Anchor Use with AW-504
	WW-103-13	Jamb "F" Anchor Use with AW-800 & AW-850
	WW-103-14	Jamb "F" Anchor Use with AW-804
	WW-333-01	Temporary Glazing Retainer
	WW-372	Captured Mullion Zone Plug 1 3/4" Infill

# RELIANCE™-HTC INSTALLATION MANUAL

## PARTS LIST

### STANDARD ACCESSORIES

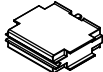
 WW-373	Captured Mullion Zone Plug 2" Infill
 WW-382	SSG Mullion Bridge 1 3/4" Infill
 WW-383	SSG Mullion Bridge 2" Infill