

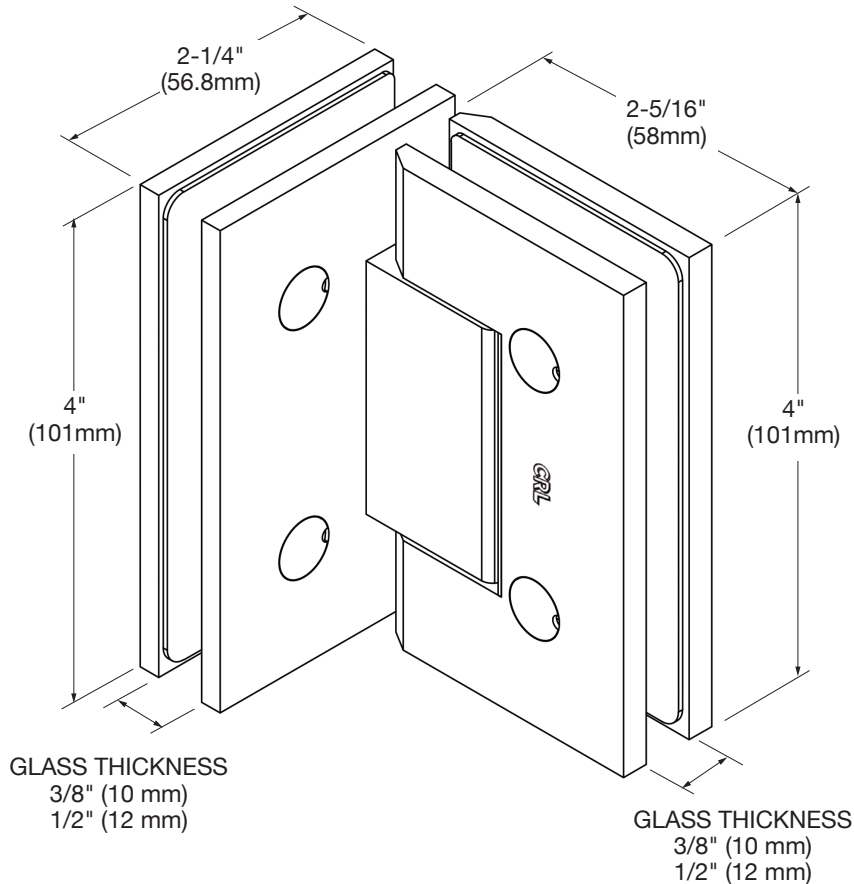

*** SEE TEMPLATE ON BACK ***
Refer to Dimensions Shown
to Ensure Accuracy



TRENTO

90° Glass-to-Glass Hinge

CAT. NO. TNT092

***NOTE:** Do not exceed either maximum weight or width when choosing proper quantity of hinges.

Important Information:

1) This Hinge contains a dual degree pivot pin. The pivot pin is set for normal door closing position. You have the option of altering the closing position of the door 5 degrees inward by utilizing the opposite side of the pivot pin, which has been pre-machined.

2) The Trento Hinge is designed to accommodate two types of cut-outs in the glass. If the two steel pins in the body of the Hinge are left in place, the "mouse ear" cut-out option should be used. This application is recommended to prevent slippage.

Limited Lifetime Warranty

Warranted against defects in materials and workmanship for the life of the product; excludes damage from installation, maintenance, environment, or misuse

Specifications:

Glass Sizes: 3/8" (10mm) to 1/2" (12mm) thick tempered safety glass
Construction: Solid brass
Closing Type: Self-centering when within 15° of closed position
Max Clamping Screw Torque: 60-70 lbf-in (677.99-790.9 cN·m)

Maximum Door Capacities: Two Hinges Three Hinges

Maximum Door Weight:	150 lbs.	190 lbs.
Maximum Door Width:	40"	40"

Use of Gaskets:

One gasket on each side for either 3/8" (10mm) or 1/2" (12mm) glass

Parts Included:

Hinge	1
NAF Gaskets	4
Clamp Screw Covers	4

Parts Included:

Phillips Flat Head Screws	4
Flat Allen Head Screws	4
4mm Allen L-Key	1

Maintenance Guidelines:

- Our hinges are greased at the factory for quiet and trouble-free operation. If there is any squeaking that occurs after installation, put a drop of "3 in 1 Oil" (also known as "household oil") on the white nylon washer that the hinge body pivots on. This washer is the component that acts as a buffer, so the body of the hinge doesn't pivot directly on the brass center block. This solution doesn't require the disassembly of the hinge. **Note: Do not use spray lubricant on these hinges.** If the hinge has been disassembled, upon re-assembly, use white lithium grease to lubricate the interior mechanism.
- Never use an abrasive cleaner on the hardware. Many of the components are coated with a clear lacquer that will be irreparably damaged if subjected to harsh, abrasive chemicals. Advise your customer that drying the hardware with a clean, soft towel on a daily basis is the best way to maintain the hardware. If mineral deposits build-up, mix a couple of drops of a mild liquid soap (such as Ivory or a similar product) into a cup of warm water. Using a soft, non-abrasive cloth, clean the hardware. Rinse thoroughly with clean, warm water and dry.

For Technical Assistance in the United States and Canada 1.800.421.6144. Press 2, then option 1

C.R. Laurence Co., Inc. • 2503 E. Vernon Ave., Los Angeles, CA 90058 • 1.800.421.6144 • crlaurence.com

© Copyright 2026, C.R. Laurence Co., Inc.



IMPORTANT: Project measurements from the edge of the glass.

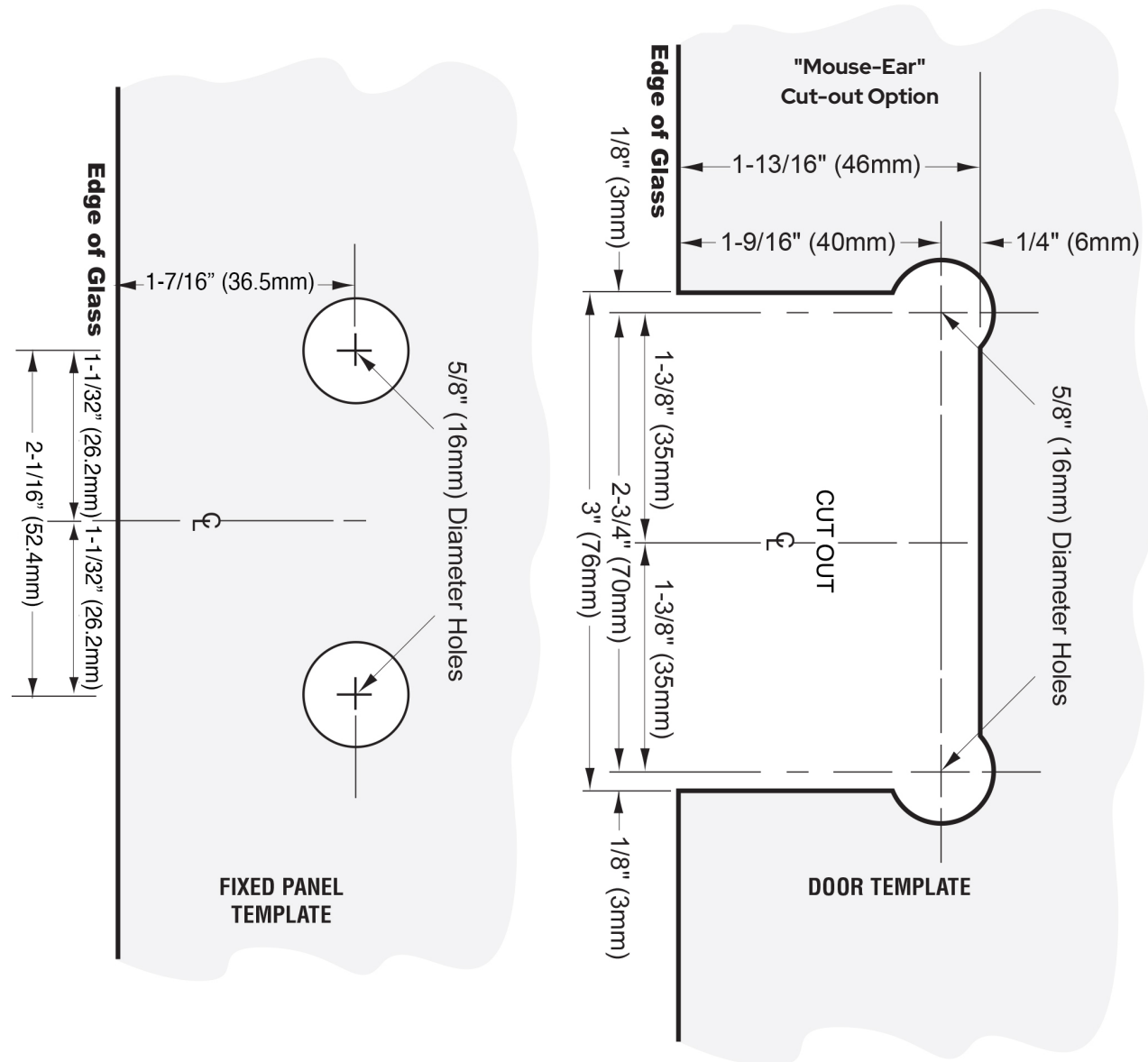

 ALWAYS USE DIMENSIONS TO ENSURE ACCURACY

TRENTO

90° Glass-to-Glass Hinge

CAT. NO. TNT092

"Mouse-Ear" Cut-out Option

For Technical Assistance in the United States and Canada 1.800.421.6144. Press 2, then option 1

C.R. Laurence Co., Inc. • 2503 E. Vernon Ave., Los Angeles, CA 90058 • 1.800.421.6144 • crlaurence.com

© Copyright 2026, C.R. Laurence Co., Inc.



IMPORTANT: Project measurements from the edge of the glass.

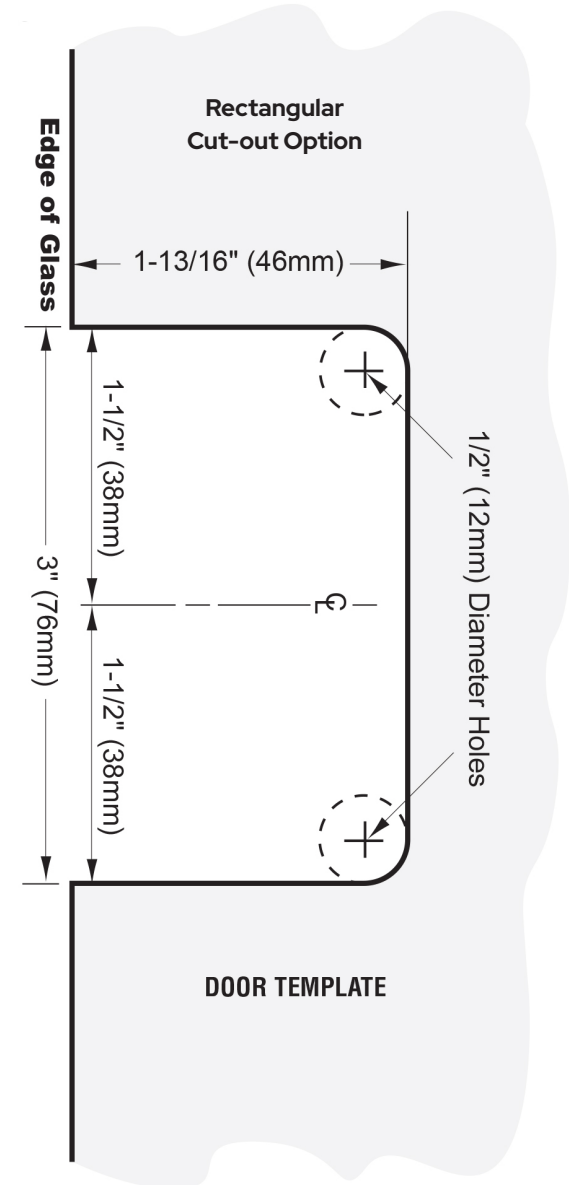
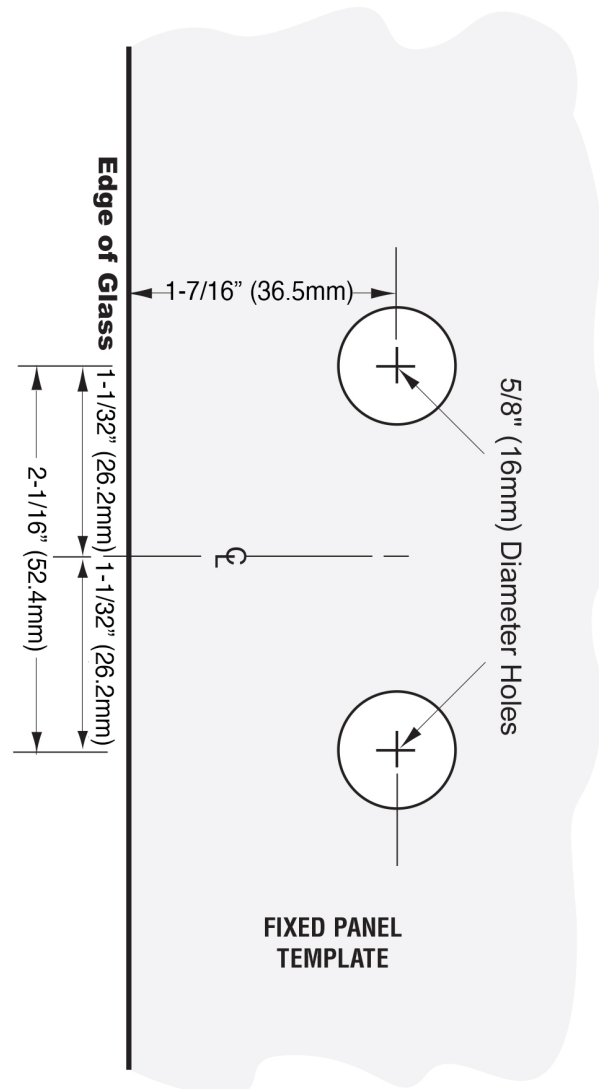

TRENTO
90° Glass-to-Glass Hinge
CAT. NO. TNT092
Rectangular Cut-out Option

For Technical Assistance in the United States and Canada 1.800.421.6144. Press 2, then option 1

C.R. Laurence Co., Inc. • 2503 E. Vernon Ave., Los Angeles, CA 90058 • 1.800.421.6144 • crlaurence.com

© Copyright 2026, C.R. Laurence Co., Inc.



Troubleshooting/Best practices

1. As a preventive measure, or if the shower door is falling out of adjustment, setting blocks can be used to hold the glass in place to make sure the glass doesn't slip. Insert hard setting blocks with a durometer rating of 85-90 between the body of the hinge and the glass cutout. This creates a physical barrier that helps secure the hinge in place, significantly reducing the likelihood of future movement or misalignment.

Situations to consider blocking

- For high-traffic commercial installations, especially in large-scale projects.
- When installing large doors that rely on glass-to-glass hinges.
- When working with glass cutouts that are near the maximum allowable size tolerances.

Note: Be sure the setting block is sized correctly to avoid putting excessive pressure on the glass. CRL offers a range of setting blocks from 1/16" to 3/8" thicknesses. Visit www.crlaurence.com for setting block parts.

2. When making deductions for door glass sizes, determine if seals are to be used, as their inclusion can affect glass sizing. If a seal is to be used adjacent to a door, the gap required for the seal may be larger than if no seal were used.
3. Apply a medium-strength threadlocker to the clamping screws to promote a secure hold.
4. Do not use power tools when installing these hinges.

General Guidelines for Installation Safety

For public safety, we recommend the use of only tempered safety glass.

Protect the installer

- Wear appropriate personal protective equipment (PPE) including protective eyewear.
- File all sharp edges on plastics and metal. Leave no sharp edges that could cause harm.
- Lift any heavy materials safely using proper techniques.
- Be OSHA compliant on jobs.

* Reference National Glass Association (NGA) installation manual for more details.

For Technical Assistance in the United States and Canada 1.800.421.6144. Press 2, then option 1

C.R. Laurence Co., Inc. • 2503 E. Vernon Ave., Los Angeles, CA 90058 • 1.800.421.6144 • crlaurence.com

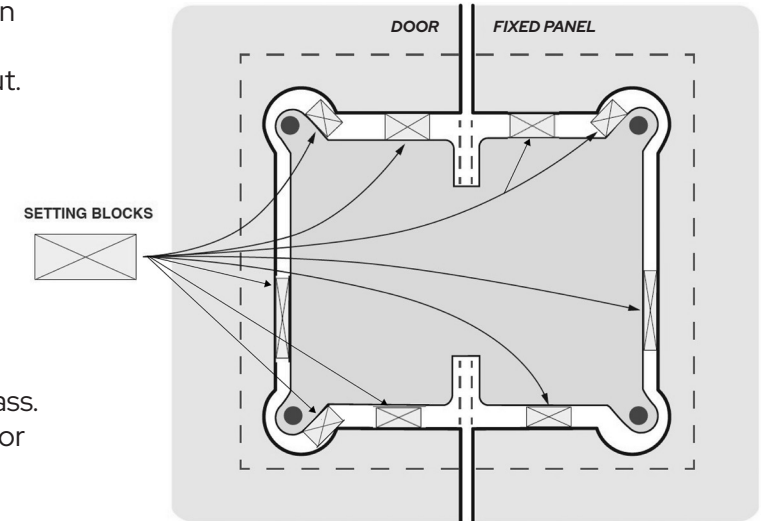

A wall mounted hinge door with setting block material between the body of the hinge and the glass cutout to block the glass into position.