



SOLAR ECLIPSE™ SINGLE BLADE Sun Control System

INSTALLATION MANUAL

NOTE

THE INSTALLATION DETAILS FOUND IN THIS PACKAGE ARE GENERIC AND ARE FOR REPRESENTATION ONLY WITH THE INTENT OF GIVING THE INSTALLATION TEAM A VISUAL REPRESENTATION AS TO HOW THE ASSEMBLIES TYPICALLY INSTALL. THE SHOP SUBMISSION DRAWINGS AND DETAILS ARE THE GOVERNING DOCUMENTS AND AS SUCH THIS PACKAGE IS TO BE USED ONLY AS A RESOURCE.

FOLLOW SEALANT MANUFACTURERS' RECOMMENDATIONS FOR USE AND APPLICATION OF ALL STRUCTURAL SILICONE SEALANT AND WEATHER SEAL SILICONE SEALANT.

CUSTOMER / PROJECT QUALITY ASSURANCE PROCEDURES ARE SEPARATE DOCUMENTS AND ARE TO BE FOLLOWED IN CONJUNCTION WITH THIS MANUAL.

SOLAR ECLIPSE™ SINGLE BLADE SUNSHADE INSTALLATION MANUAL

TABLE OF CONTENTS

GENERAL INFORMATION

Product Use.....	Page 3
Glazing Practices.....	Page 4
Protection and Storage.....	Page 5
Check Material.....	Page 5
Field Conditions.....	Page 5
Cleaning Materials.....	Page 6
Section 1 Reliance Curtain Wall	
1.1 Reliance Horizontal Fabrication & Installation.....	Page 7 - 11
1.2 Reliance Vertical Fabrication & Installation.....	Page 12 - 16
Section 2 Center Set Storefronts	
2.1 Horizontal Fabrication & Installation.....	Page 17 - 20
2.2 Vertical Fabrication & Installation.....	Page 21 - 23
Section 3 Sunshade Blade Splices	
3.1 Splice Connection Fabrication and Assembly.....	Page 24 - 27
Section 4 Adjustable Anchor Installation	
4.1 Blade and anchor angle instructions.....	Page 28
Section 5 Sunshade Layout	
5.1 Horizontal and Corner Layout for Splices.....	Page 29
5.2 Vertical Layout for Splices.....	Page 30
Parts List.....	Page 31 - 33

SOLAR ECLIPSE™ SINGLE BLADE SUNSHADE INSTALLATION MANUAL

GENERAL INFORMATION

PRODUCT USE

The **SOLAR ECLIPSE™ SINGLE BLADE** sun control system is intended for fabrication, assembly, sealing, installation and glazing by professionals with appropriate knowledge and experience of the system(s) and their incorporation into various building conditions.

Consult sealant manufacturer for review and recommendation of sealant application. Follow sealant manufacturer's recommendations and literature for proper installation.

The fabrication and installation of a structural silicone-glazed (SSG) or wet glazed system requires more technical knowledge and experience than is required for a conventional pressure-glazed or dry glazed system. The glazing contractor should take all steps as outlined and required by the structural silicone sealant manufacturer, glass fabricator, framing manufacturer, and the project professional engineer of record as well as follow local building code requirements and industry best practices to ensure the proper installation and safe performance of the SSG system.

The glazing contractor for each project needs to ensure compliance with each step, including, but not limited to, design reviews, formal adhesion testing, formal compatibility testing, project specification compliance, validating procedures, field testing, and quality control validation of installed product and surrounding conditions.

Testing of component materials for use in a SSG or wet glazed system is mandatory to fulfill project specifications and warranty requirements and must be submitted by the glazing contractor to the structural silicone manufacturer. All materials that comprise the structural silicone joint, such as the framing system (with the job-specific finish) and job-specific glass must be tested by the structural silicone manufacturer for compatibility and adhesion. All other accessory materials in contact with the structural silicone, such as setting blocks, spacers, gaskets, sweeps, air seals and expansion joints, must also be submitted to the silicone sealant manufacturer for compatibility testing.

To ensure that nothing has changed in formulation or chemistry since the initial tests, subsequent testing during periodic time frames of the project is to be conducted to confirm continued acceptance of the material for use on the project.

To ensure the structural performance and integrity of the insulating glass unit (IGU), the glazing contractor must submit the project shop drawings to the glass fabricator to obtain approval for use of their product(s) in any 2, 3 or 4-sided SSG applications.

Quality control procedures for field glazing are to be increased beyond those required for shop glazing. Job conditions will normally have dust, dirt, and other construction debris on the surfaces where structural silicone is to be applied. Great care should be exercised in cleaning and preparing these surfaces for silicone application. The recommendations of the silicone sealant manufacturer are to be strictly enforced and followed. The fabrication and installation of the SSG system and its components, whether shop or field glazed, should be governed by a quality control program, and all steps, procedures, and test reports should be documented throughout the project.

Prior to installation of any SSG system, refer to industry documents (e.g., AAMA Curtain Wall Design Guide Manual, ASTM C1401-14, and AAMA SSGDG-17) for detailed instructions and recommendations.

SOLAR ECLIPSE™ SINGLE BLADE SUNSHADE INSTALLATION MANUAL

THE GLAZING CONTRACTOR ASSUMES FULL RESPONSIBILITY FOR ENSURING COMPLIANCE WITH THE ABOVE AND ASSUMES FULL LIABILITY FOR ANY ISSUES ARISING FROM NONCOMPLIANCE.

GLAZING PRACTICES

The air and water performance of the **SOLAR ECLIPSE™ SINGLE BLADE** sun control system is directly related to the completeness and integrity of the installation process, including but not limited to the assembly seals of the framing joinery, the installed glazing gaskets, and the alignment of the framing joinery glazing plane. Before glazing, verify the glazing pocket width and glazing infill thickness, as both must be in tolerance to assure adequate edge pressure and to achieve the desired air and water performance levels. (In general, framing systems utilizing 1” insulating glass are designed to accommodate a thickness variance of +/- 1/32”). Note: Excessive pressure can cause glass breakage and/or IGU failure. Consult the glass manufacturer for their recommended edge pressure per lineal inch. To achieve the designed and tested air and water performance, best practices include:

1. Surfaces to be sealed should be cleaned with isopropyl alcohol or solvent and dried as recommended by sealant manufacturer to remove all dirt and cutting oils. Sealant at shear blocks should be a minimum 3/16” diameter nominal placed completely around the top, face and bottom of the shear block without gaps in the sealant. Exposed surfaces should be cleaned after installing the horizontal. Inspect joint for complete sealant contact, especially where the horizontal meets the face of the vertical member. Repair joint as required.
2. Glazing gaskets should be cut ¼” longer per foot, and lay flat, preferably for 24 hours.
3. Gaskets should be cut as single monolithic pieces and “crowded” during their installation to avoid corner gaps caused by post-installation relaxation.
4. The interior glazing gasket should be installed so as to avoid stretching, buckles, or tears.
5. Corners must be cut square, and at a slight angle when required to conform to the bevel on the intersecting gasket; sealed and butted together.
6. Gasket corner joinery must also be crowded, and sealant applied onto the gasket contact frame surface and into gasket reglet raceway where applicable.
7. Gasket corner seals are to be done just prior to installing glass, while the sealant is still wet and uncured, and ensure exterior gaskets are installed so as to place the glass into it’s final in-service condition and allow the sealant to conform to optimum configuration. Note: If the sealant cures prior to glazing, the cured sealant could create excessive edge pressure onto the glass and has the potential to cause glass breakage.
8. The glass must be checked for squareness, size dimension, and thickness along the edges paying attention to any variances from center edge to corner edge.
9. Check the placement of the installed glass and verify there is proper edge bite into the pocket, and proper edge clearance from framing elements.
10. After sealant has set and a representative amount of the wall has been installed and glazed (250 square feet or more) run a water hose test in accordance with AAMA 501.2 specifications to check installation. On large projects the hose test should be repeated during the glazing operation. Consult and follow NGA’s GANA Manual and FGMA Glazing Manual for proper glazing technique and procedure.

Variations on the details shown are inevitable and are not the responsibility of Oldcastle BuildingEnvelope when drawn by others. Oldcastle BuildingEnvelope strongly encourages its customers to utilize Oldcastle BuildingEnvelope supplied calculations and shop drawings.

SOLAR ECLIPSE™ SINGLE BLADE SUNSHADE INSTALLATION MANUAL

For Structural Silicone Glazing applications, the stress on the silicone should not exceed 20 PSI. Consult sealant manufacturer for specific applications to ensure proper loading on silicone joint. Alternate spacer gaskets are available to accommodate larger sealant contact widths. Consult your nearest Oldcastle BuildingEnvelope facility for assistance.

Consult glass manufacturer for correct setting block location and length for glass sizes in excess of 40 sq.ft.

PROTECTION AND STORAGE

Handle all material carefully. Do not drop from the truck. Stack with adequate separation so the material will not rub together. Store material off the ground, protecting against the elements and other construction hazards by using a well-ventilated covering. Remove material from package if wet or located in a damp area. For further guidelines consult AAMA publication CW-10 "Care and Handling of Architectural Aluminum From Shop to Site."

BUILDING CODES

Oldcastle BuildingEnvelope does not control the application or selection of its product configurations, sealant or glazing material and assumes no responsibility thereof. It is the responsibility of the owner, architect, and installer to make these selections in strict compliance with applicable laws and building codes.

CHECK MATERIAL

Check glass dimensions for overall size as well as thickness. Oldcastle BuildingEnvelope cannot be held responsible for gaskets that are not watertight due to extreme glass tolerances. Check all material upon arrival at job site for quality and to determine any shipping damage.

Using the contract documents, completely check the surrounding conditions that will receive your materials. Notify the general contractor by letter of any discrepancies before proceeding with the work. Failure to do so constitutes acceptance of work by other trades.

Check shop drawings, installation instructions, architectural drawings, and shipping lists to become familiar with the project. The shop drawings take precedence and include specific details for the project. The installation instructions are of a general nature and cover the most common conditions. Due to varying job conditions all sealant used must be approved by the sealant manufacturer to ensure it will perform per the conditions shown on the instructions and shop drawings. The sealant must be compatible with all surfaces in which adhesion is required, including other sealant surfaces. Use primers where directed by sealant manufacturer. Properly store sealant at the recommended temperatures and check sealant for remainder of shelf life before using.

FIELD CONDITIONS

All material to be installed must be plumb, level and true. Aluminum to be placed in direct contact with masonry or incompatible material should be isolated with a heavy coat of zinc chromate, bituminous paint or non-metallic material.

SOLAR ECLIPSE™ SINGLE BLADE SUNSHADE INSTALLATION MANUAL

CLEANING MATERIALS

Cement, plaster terrazzo, alkaline and acid-based materials used to clean masonry are very harmful to finishes. Any residue should be removed with water and mild soap immediately or permanent staining will occur. A spot test is recommended before any cleaning agent is used. Refer to the **Architectural Finish Guide** in the Detail Catalog.

SOLAR ECLIPSE™ SINGLE BLADE SUNSHADE INSTALLATION MANUAL

1.1 Reliance Horizontal Installation

- 1) After glass has been installed into the Reliance & Reliance-TC Type II curtain walls, install the vertical pressure plates. Locate the SS-206-01 sunshade anchor at the face of the WW-284 pressure plate and match drill through pressure plate, GP-197 (GP-198) dual-durometer isolator and front wall of the mullion stem using a .281 drill bit. On Reliance-TC Type II you will drill out the mullion stem using a 13/32" hole and insert a 3/8" O.D. pipe sleeve for added support. SEE FIGURE 2. NOTE: Anchor is handed so must be installed based on project specified blade angle. See page 25 for installation information for blade angles. SEE FIGURE 1 page 4 and FIGURE 3 page 5
- 2) Reliance-TC Type I & Reliance-TCIG will utilize a similar installation. The face of the WW-566 (WW-466) mullion is integral, so you will only match drill through the face portion of the extrusion using a 13/32" drill and inserting a 3/8" O.D. pipe sleeve into the stem for added support. SS-206-03 or SS-206-04 anchor will be used on the Reliance-TC Type I due to offset stem and based on blade angle. The sunshade anchor may be pre-installed onto the Reliance-TC Type I, where these anchors must be field installed on all other curtain wall products. SEE FIGURE 4 page 5

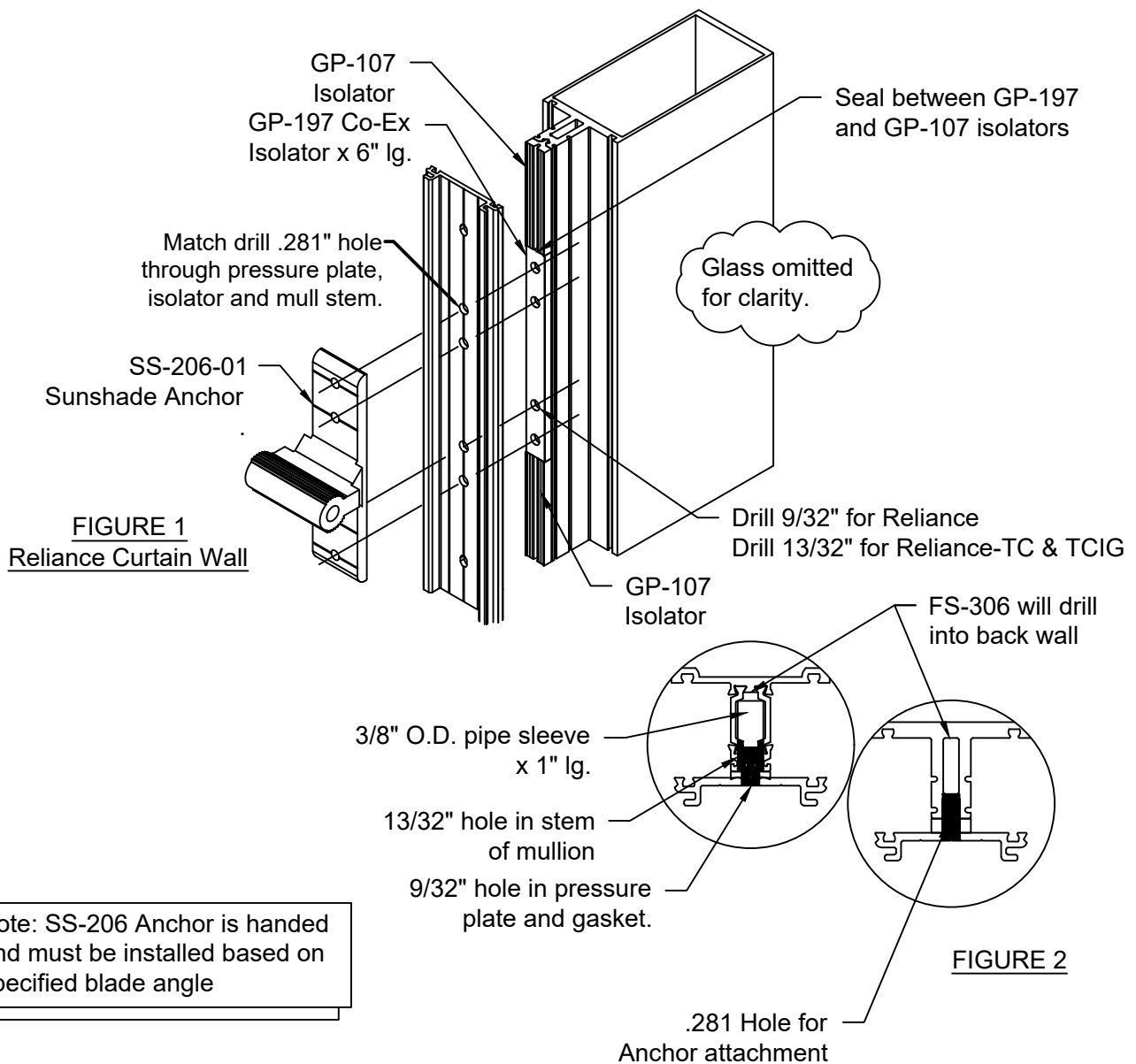

Note: SS-206 Anchor is handed and must be installed based on specified blade angle

SOLAR ECLIPSE™ SINGLE BLADE SUNSHADE INSTALLATION MANUAL

1.1 Reliance Horizontal Installation (continued)

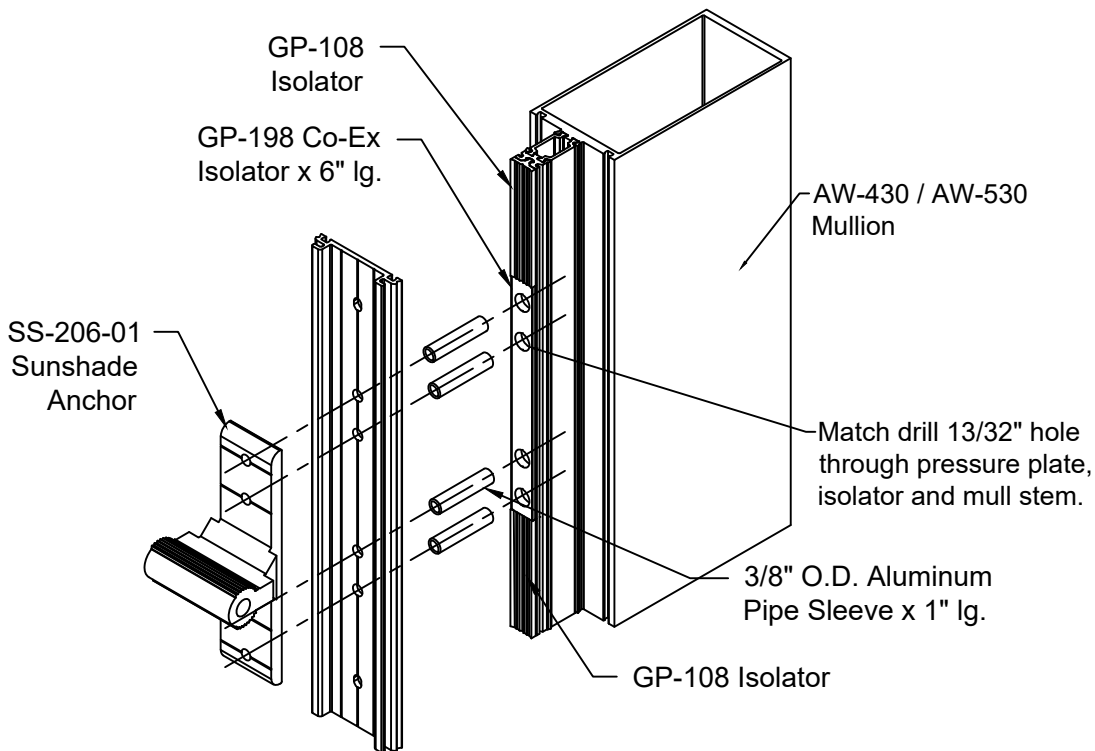

FIGURE 3
Reliance-TC Type II
Curtain Wall

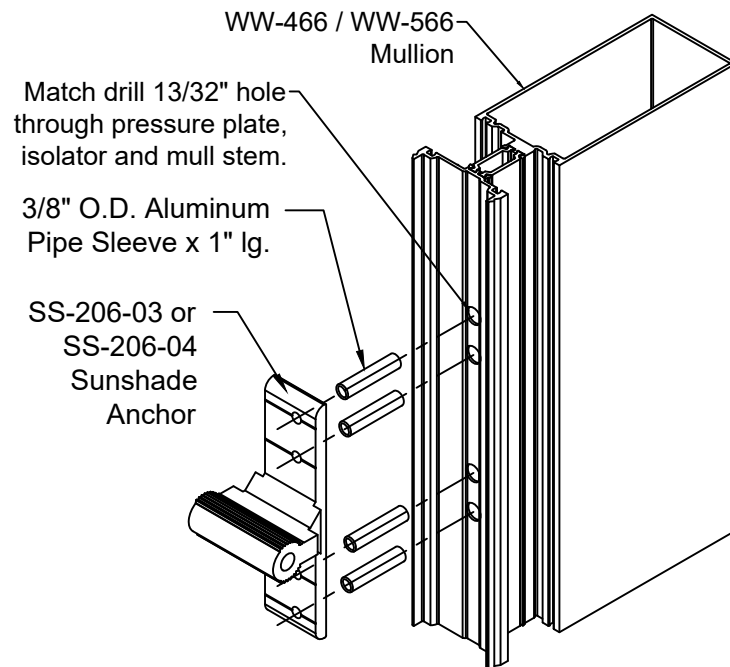

FIGURE 4
Reliance-TC Type I &
Reliance-TCIG
Curtain Wall

Note: SS-206 Anchor is handed and must be installed based on specified blade angle

SOLAR ECLIPSE™ SINGLE BLADE SUNSHADE INSTALLATION MANUAL

1.1 Reliance Horizontal Installation (continued)

- 3) Coat lead threads of FS-306 ($\frac{1}{4}$ "-20 x 3" HWH Bi-Flex) fastener with sealant and attach the SS-206 anchor by drilling into the front wall of the tubular section of the mullion. Tighten the bolts to 90 inch/lbs. (SEE FIGURE 5 & 6)

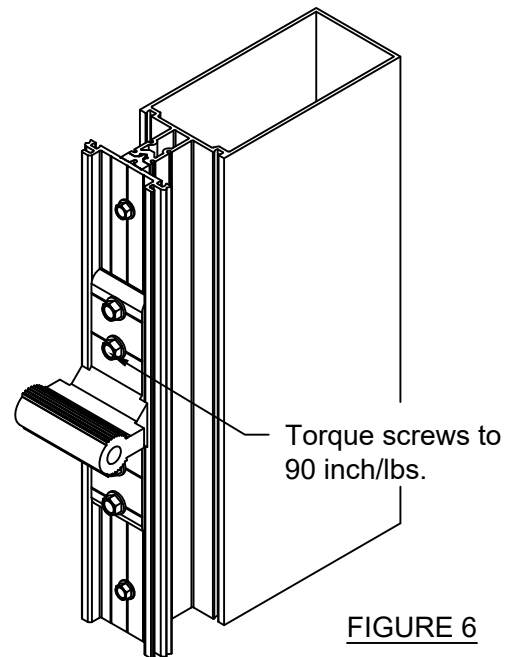
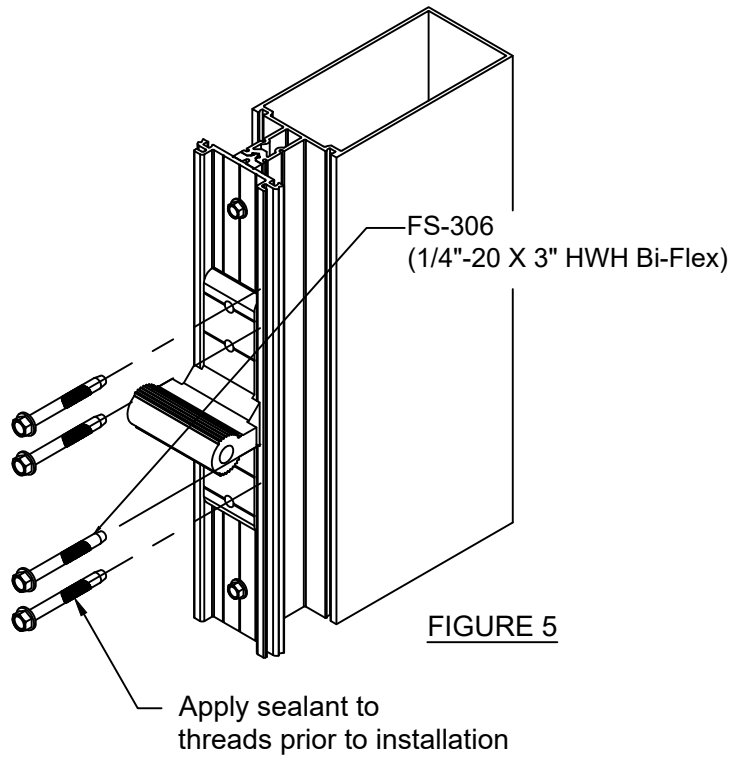

SOLAR ECLIPSE™ SINGLE BLADE SUNSHADE INSTALLATION MANUAL

1.1 Reliance Horizontal Installation (continued)

- 4) Blade angle should have been determined prior to installing the SS-206 anchor. (See page 25 for information on setting blade angle). SEE FIGURE 7
- 5) Slide SS-208 mounting arm over the previously installed SS-206 anchor. Match drill at least two holes through the SS-208 into the SS-206 using #21 (.159" Ø) drill. SEE FIGURE 8
- 6) Insert FS-313 drive pins into mounting arm and drive into anchor. Install pins on top side when possible. Once pins are installed, bolt assembly together using a FS-308 (3/8" - 16 x 3-1/4" Hex Bolt), FS-352 Lock Nut and (2) FS-311 Fender Washers. SEE FIGURE 8.

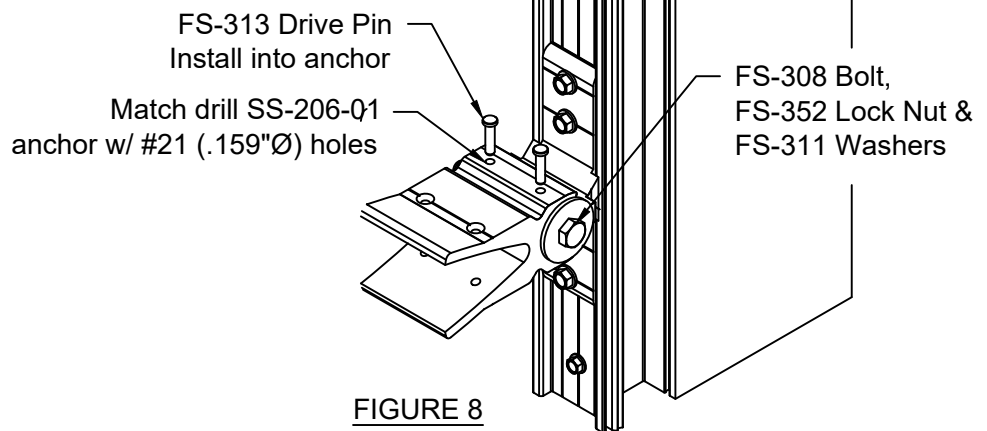
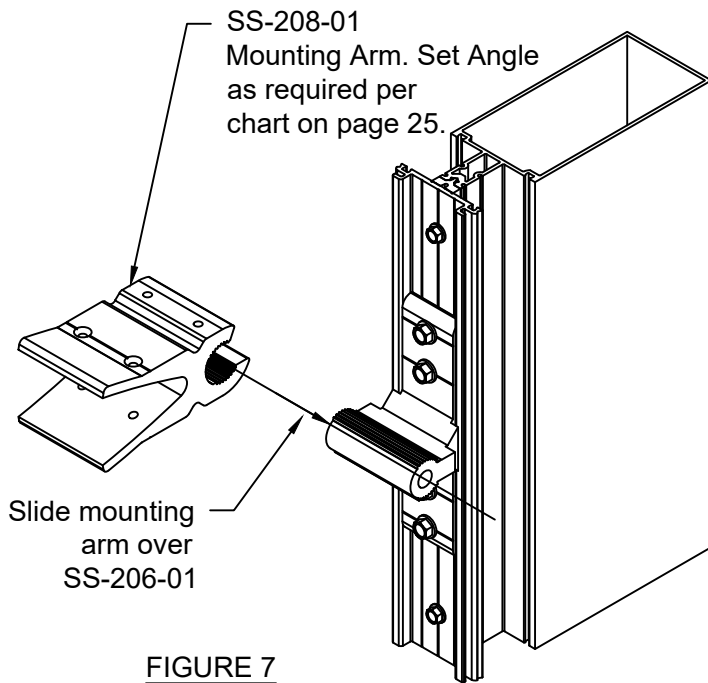

SOLAR ECLIPSE™ SINGLE BLADE SUNSHADE INSTALLATION MANUAL

1.1 Reliance Horizontal Installation (continued)

- 7) Blades for adjustable sunshades are available in widths from 8" to 14". See parts list at back of manual for extrusion numbers.
- 8) Blades should be spliced at 10 foot or as required based on Engineer's review. See page 22 - 24 & 26 for splice information.
- 9) Blades are attached to the SS-208 mounting arm using four (4) FS-148 (#10 x 3/4" UCPFH St. Steel) fasteners. (SEE FIGURE 9)
- 10) WW-216 face cap will be notched to wrap around anchors. Face cap will be spliced at each anchor. SEE FIGURE 10 for face cap fabrication.
- 11) Final assembly of Solar Eclipse II is shown in FIGURE 11 below.

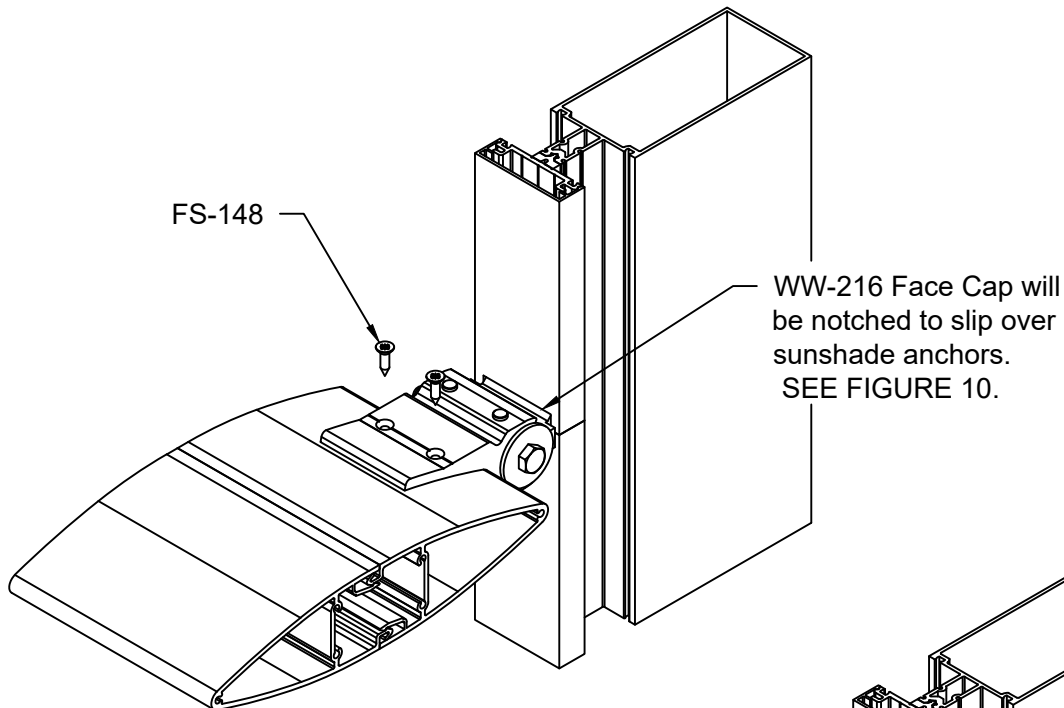

FIGURE 9

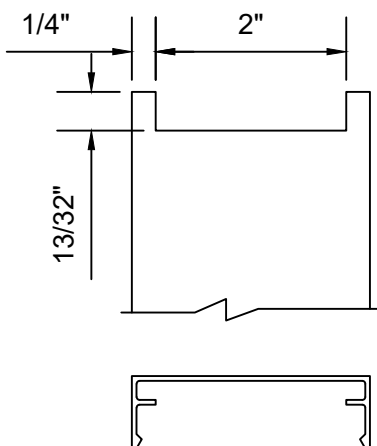

FIGURE 10

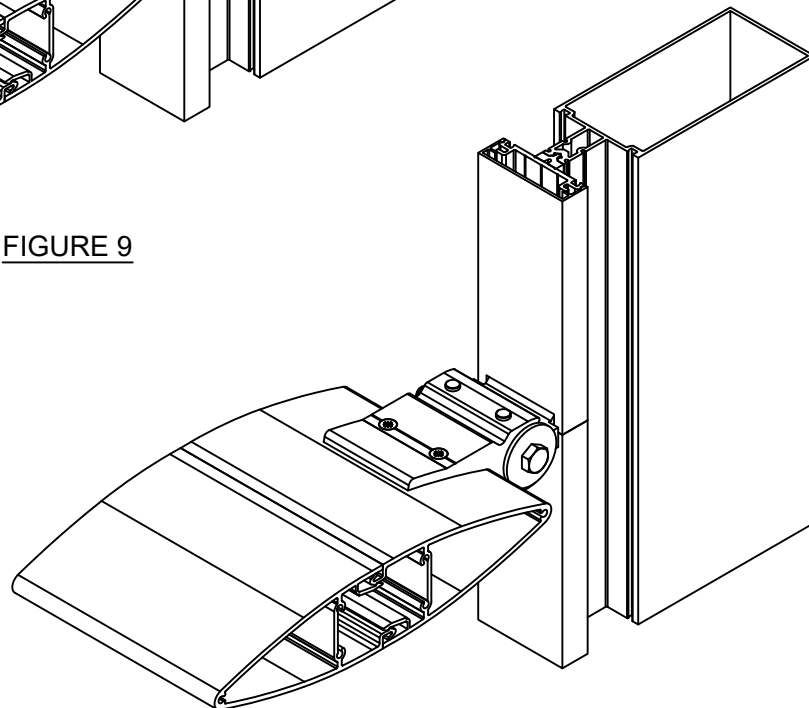

FIGURE 11

SOLAR ECLIPSE™ SINGLE BLADE SUNSHADE INSTALLATION MANUAL

1.2 Reliance Vertical Installation

- 1) After glass has been installed into the Reliance & Reliance-TC Type II curtain walls, install the vertical pressure plates. Locate the SS-207-01 sunshade anchor at the face of the WW-284 pressure plate and match drill through pressure plate, GP-197 (GP-198) dual-durometer isolator and front wall of the mullion stem using a .281 drill bit. SEE FIGURE 10. NOTE: Anchor is handed so must be installed based on project specified blade angle. See page 25 for installation information for blade angles. SEE FIGURE 11 and FIGURE 12 page 10
- 2) Reliance-TC Type I has similar installation. The face of the WW-566 (WW-466) mullion is integral, so you will only match drill through the face portion of the extrusion. SS-207-02 or SS-207-03 anchor will be used on the Reliance-TC Type I due to offset stem and based on blade angle. The sunshade anchor may be pre-installed onto the Reliance-TC Type I, where these anchors must be field installed on all other curtain wall products. SEE FIGURE 12 page 10

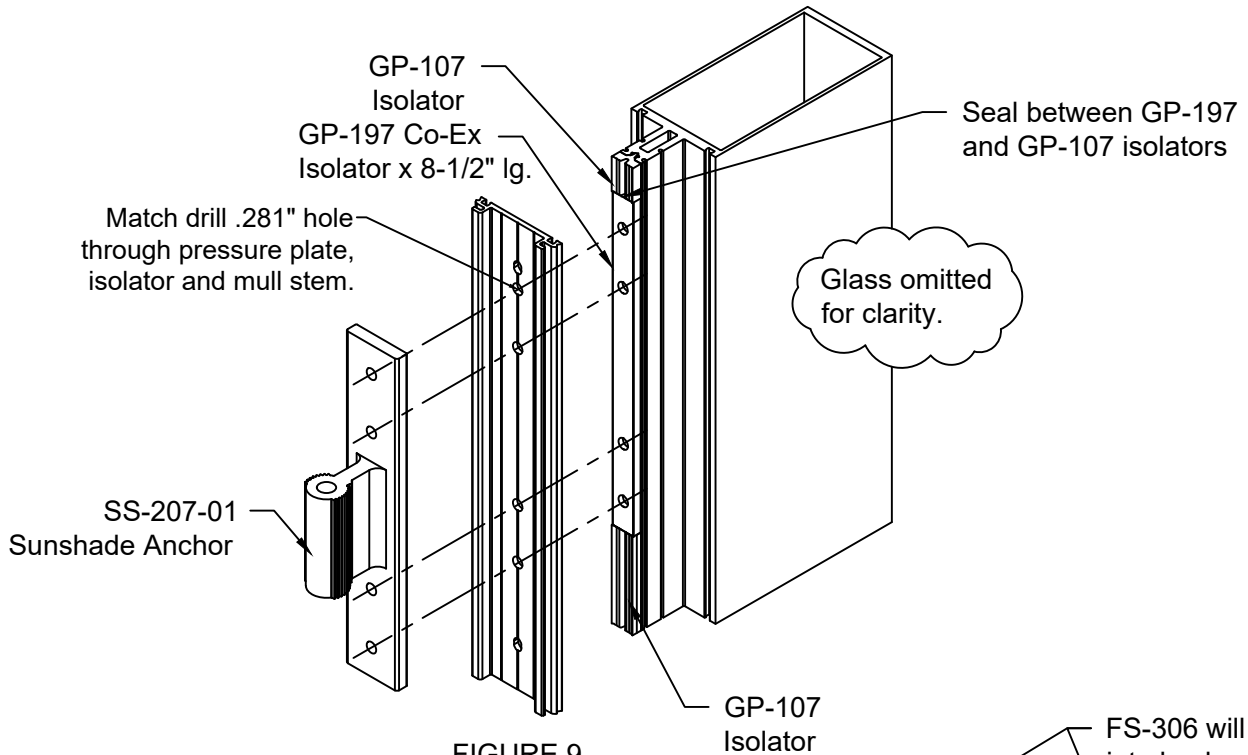

FIGURE 9
 Reliance Curtain Wall

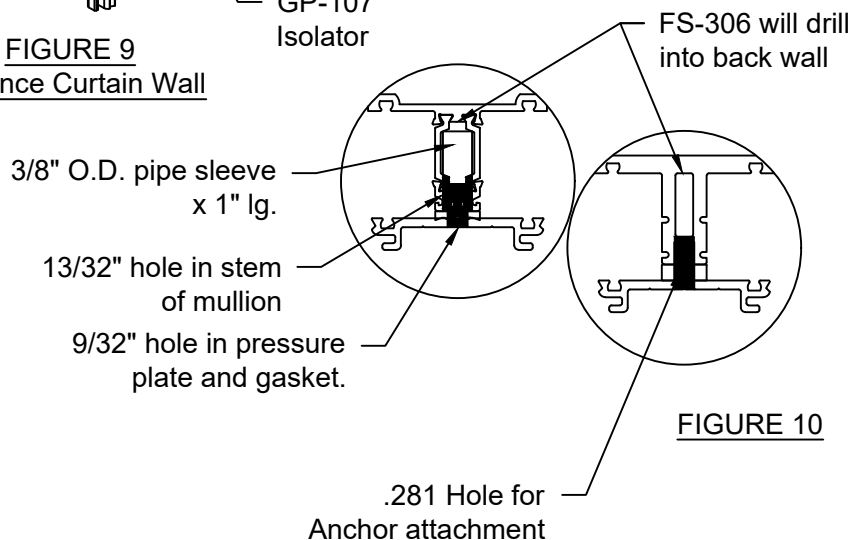

FIGURE 10

Note: SS-207 Anchor is handed and must be installed based on specified blade angle

SOLAR ECLIPSE™ SINGLE BLADE SUNSHADE INSTALLATION MANUAL

1.2 Reliance Vertical Installation (Continued)

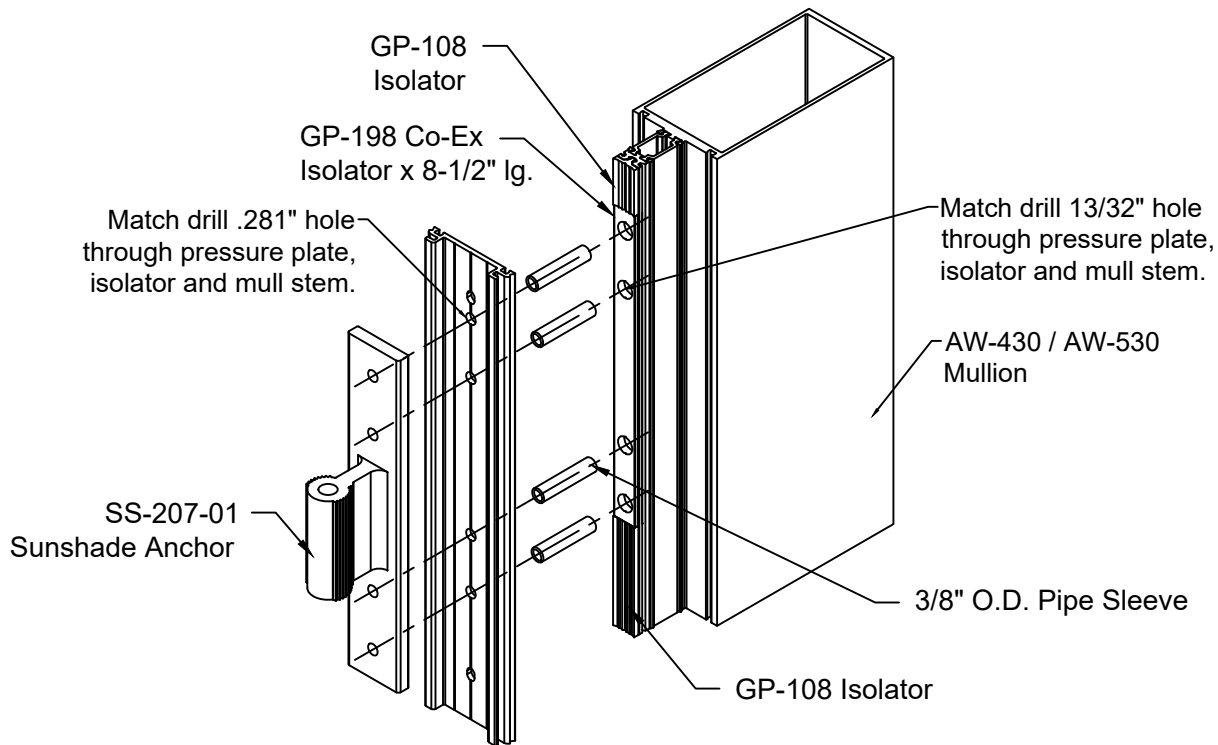

FIGURE 11
Reliance-TC Type II
Curtain Wall

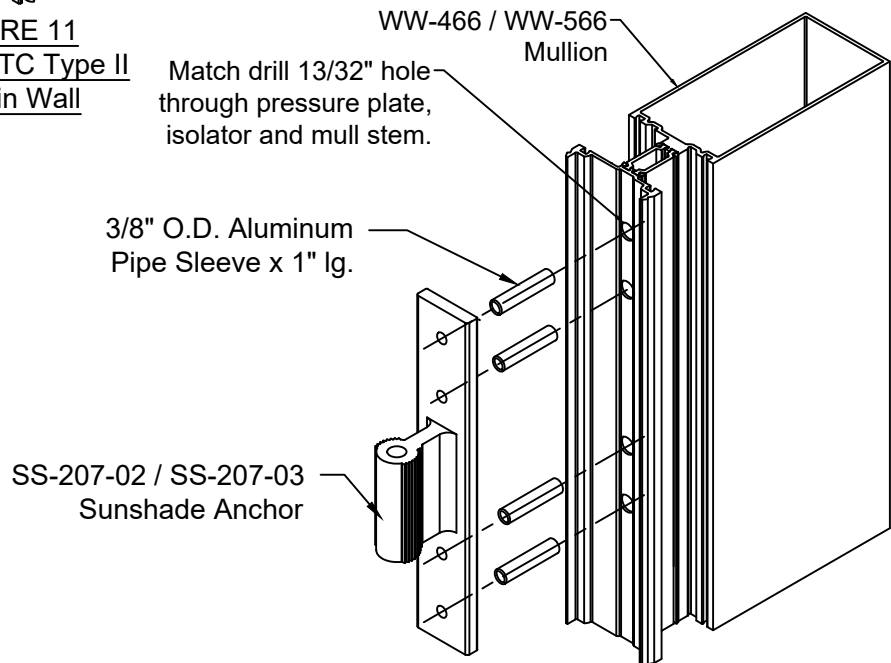

FIGURE 12
Reliance-TC Type I
Curtain Wall

Note: SS-207 Anchor is handed and must be installed based on specified blade angle

SOLAR ECLIPSE™ SINGLE BLADE SUNSHADE INSTALLATION MANUAL

1.2 Reliance Vertical Installation (Continued)

- 3) Coat lead threads of FS-306 (1/4"-20 x 3" HWH Bi-Flex) fastener with sealant and attach the SS-207 anchor by drilling into the front wall of the tubular section of the mullion. Tighten the bolts to 90 inch/lbs. (SEE FIGURE 13 & 14)

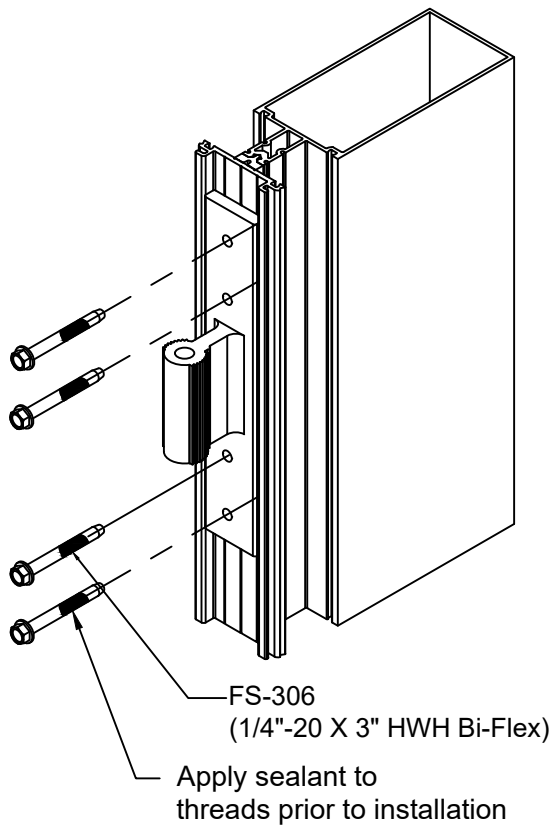

FIGURE 13

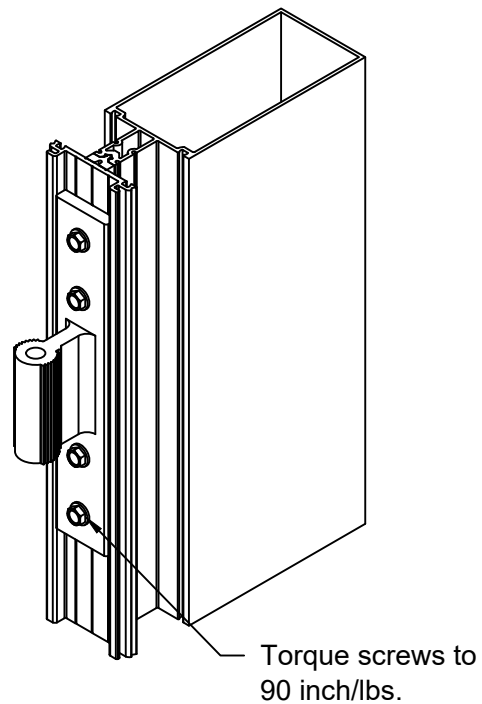
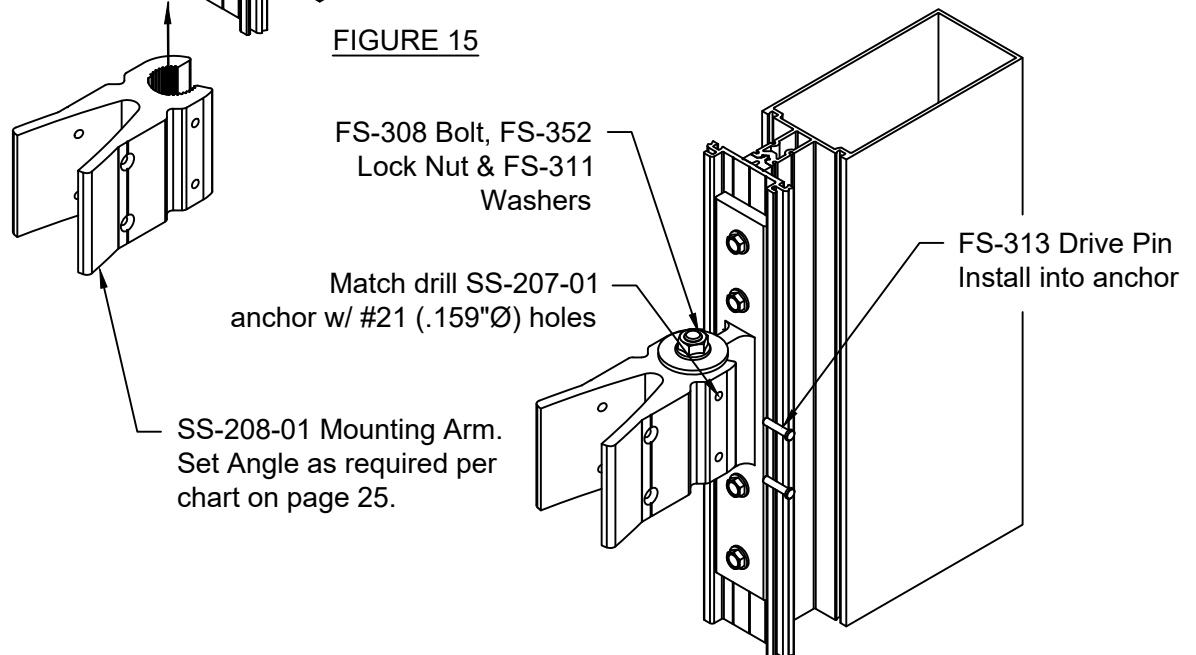
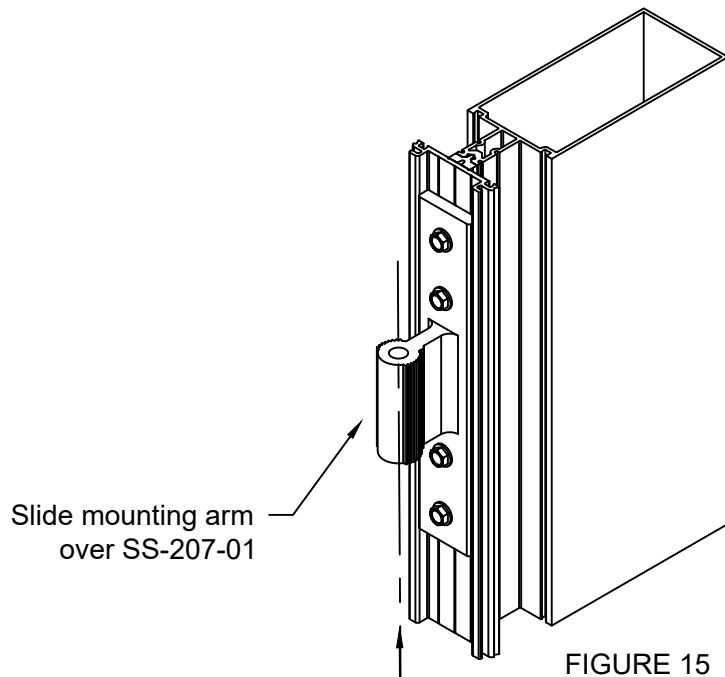

FIGURE 14

SOLAR ECLIPSE™ SINGLE BLADE SUNSHADE INSTALLATION MANUAL

1.2 Reliance Vertical Installation (Continued)

- 4) Blade angle should have been determined prior to installing the SS-207 anchor. (See page 25 for information on setting blade angle). SEE FIGURE 15
- 5) Slide SS-208-01 mounting arm over the previously installed SS-207 anchor. Match drill at least two holes through the SS-208-01 into the SS-207 using #21 (.159" Ø) drill. SEE FIGURE 16
- 6) Insert FS-313 drive pins into anchors and drive into anchor. Once pins are installed, bolt assembly together using a FS-308 (3/8"-16 x 3-1/4" hex bolt), FS-352 Lock Nut and (2) FS-311 fender washers. SEE FIGURE 16



SOLAR ECLIPSE™ SINGLE BLADE SUNSHADE INSTALLATION MANUAL

1.2 Reliance Vertical Installation (Continued)

- 7) Blades for adjustable sunshades are available in widths from 8" to 14". See parts list at back of manual for extrusion numbers.
- 8) Blades should be spliced at maximum 10 foot or as required based on Engineer's review. See pages 22-24 & 27 for splice information.
- 9) Blades are attached to the SS-208-01 mounting arm using four (4) FS-148 (#10 x 3/4" UCPFH St. Steel) fasteners. SEE FIGURE 17
- 10) WW-216 face cap will be notched to wrap around anchors. Face cap will be spliced at each anchor. SEE FIGURE 18 for face cap fabrication.
- 11) Final assembly of Solar Eclipse II is shown in FIGURE 19 below.

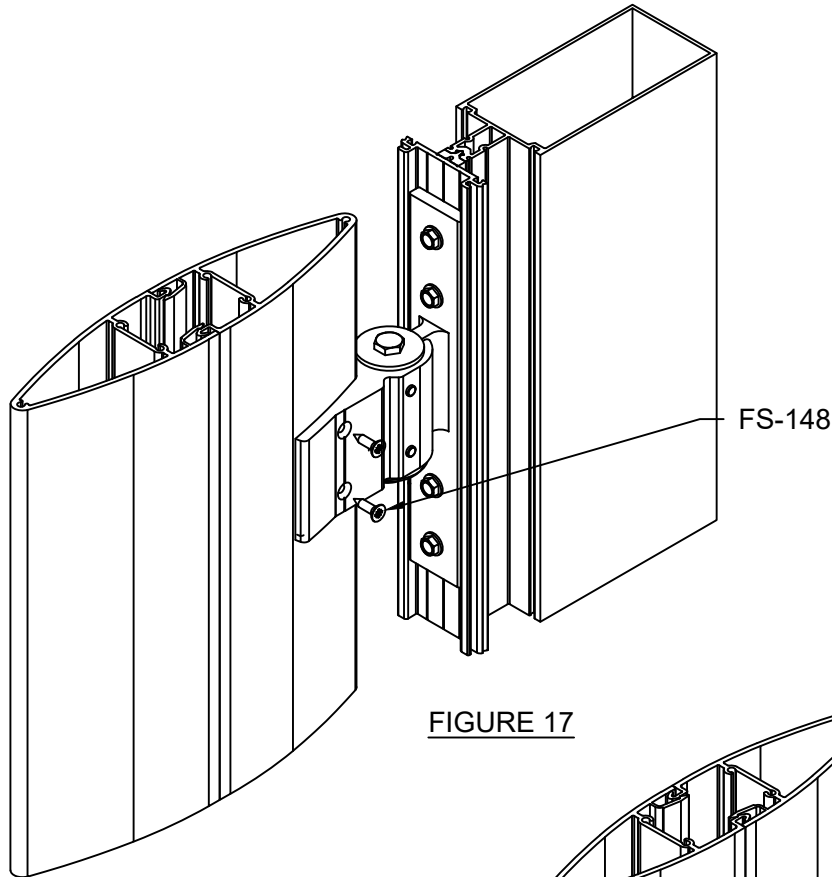

FIGURE 17

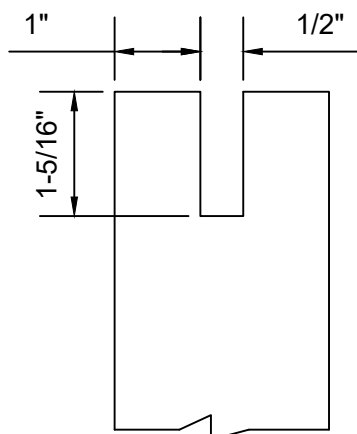

FIGURE 18

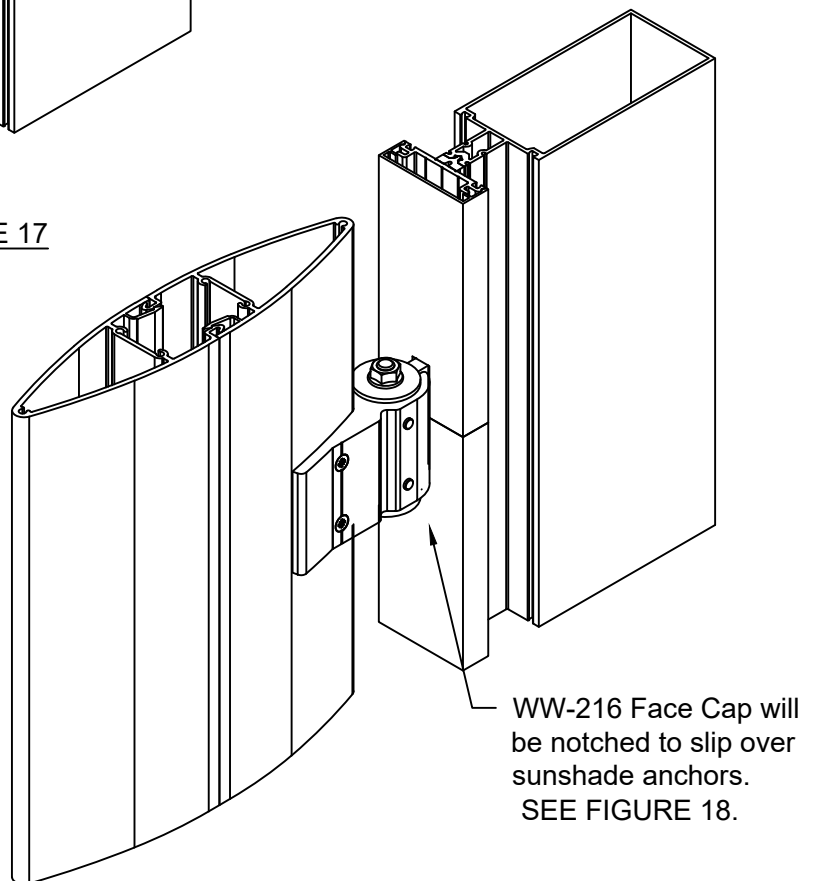

FIGURE 19

SOLAR ECLIPSE™ SINGLE BLADE SUNSHADE INSTALLATION MANUAL

2.1 Storefront Horizontal Installation

- 1) Drill face of mullion using a #11 (.191" Ø) drill per FIGURE 20 & 21
- 2) Install anchor onto face of mullion using eight FS-147 (1/4"-20 x 3/4" PFH Type F Stainless Steel) fasteners. SEE FIGURE 22

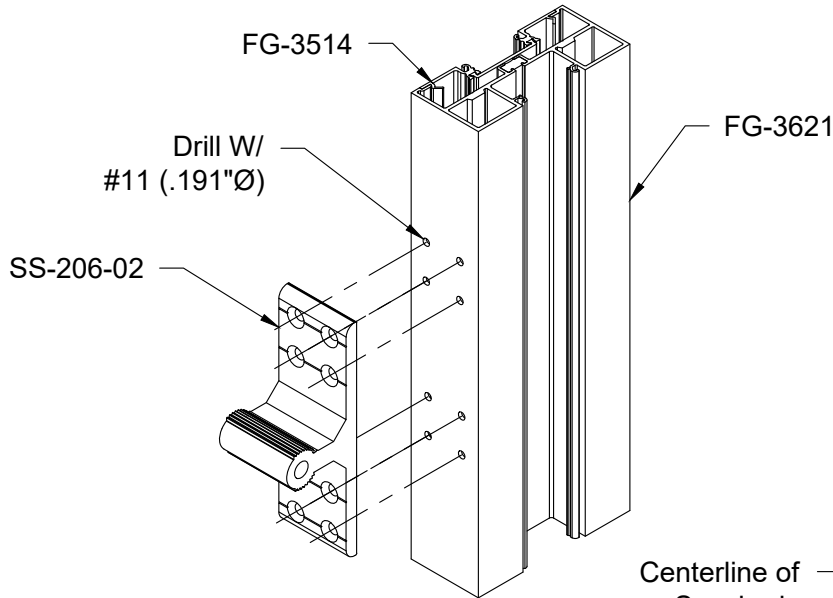

FIGURE 20

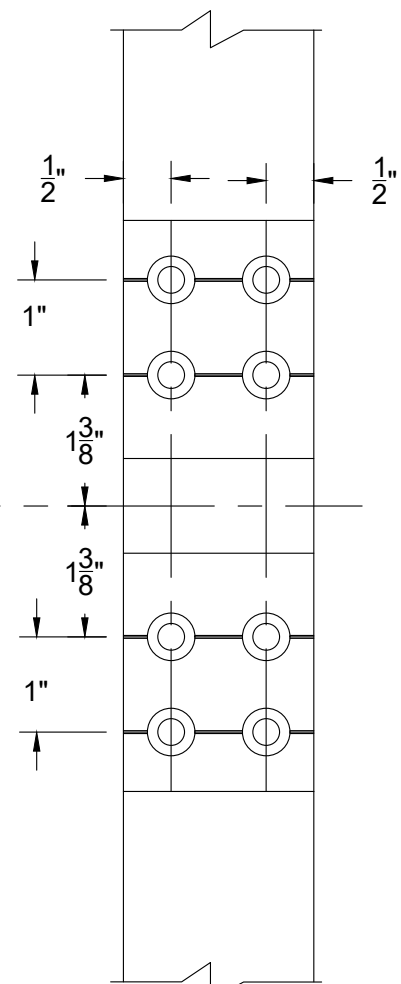

FIGURE 21

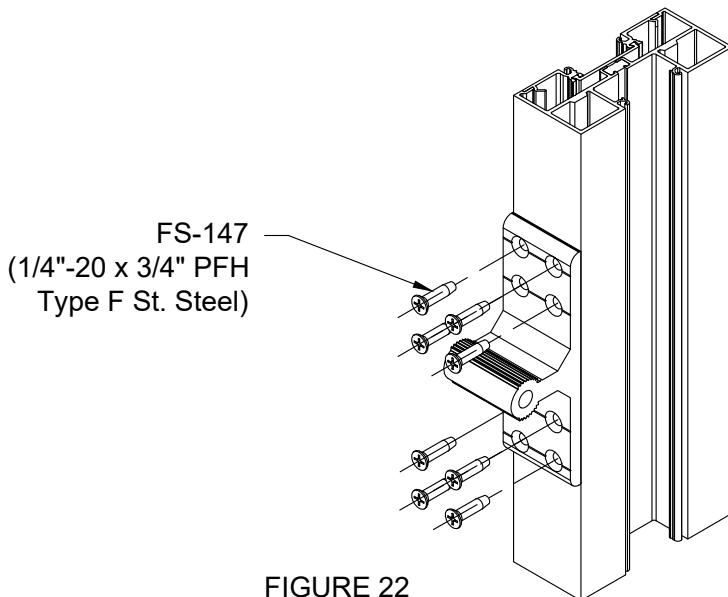

FIGURE 22

Note: SS-206 Anchor is handed and must be installed based on specified blade angle

SOLAR ECLIPSE™ SINGLE BLADE SUNSHADE INSTALLATION MANUAL

2.1 Storefront Horizontal Installation (continued)

- 3) Blade angle should have been determined prior to installing the SS-206 anchor. (See page 25 for information on setting blade angle).
- 4) Slide SS-208-02 mounting arm over the previously installed SS-206-02 anchor. Match drill at least two holes through the SS-208 into the SS-206 using #21 (.159" Ø) drill. SEE FIGURE 23
- 5) Insert FS-313 drive pins into anchors and drive into anchor. Install pins on top side when possible. Once pins are installed, bolt assembly together using a FS-307 (3/8"-16 x 2-3/4" Hex Bolt), FS- 352 lock nut and (2) FS-311 fender washers. SEE FIGURE 24

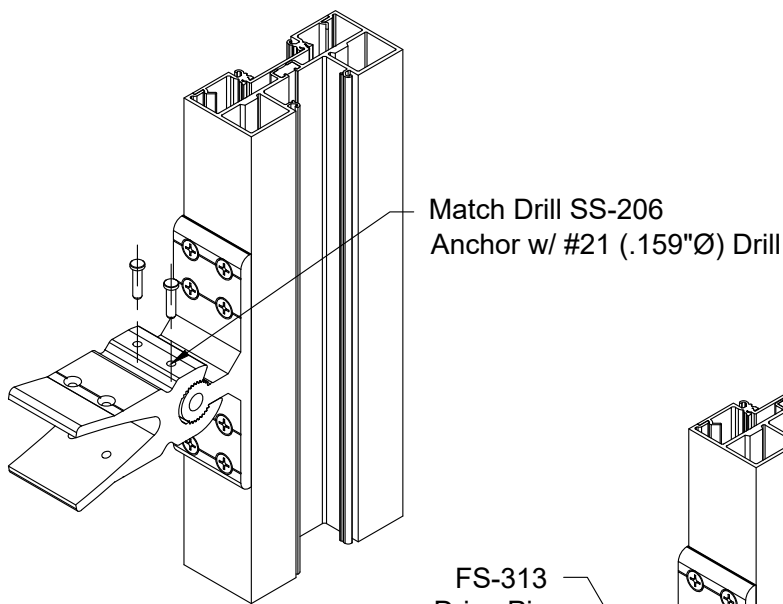

FIGURE 23

Match Drill SS-206
Anchor w/ #21 (.159"Ø) Drill

FS-313
Drive Pin

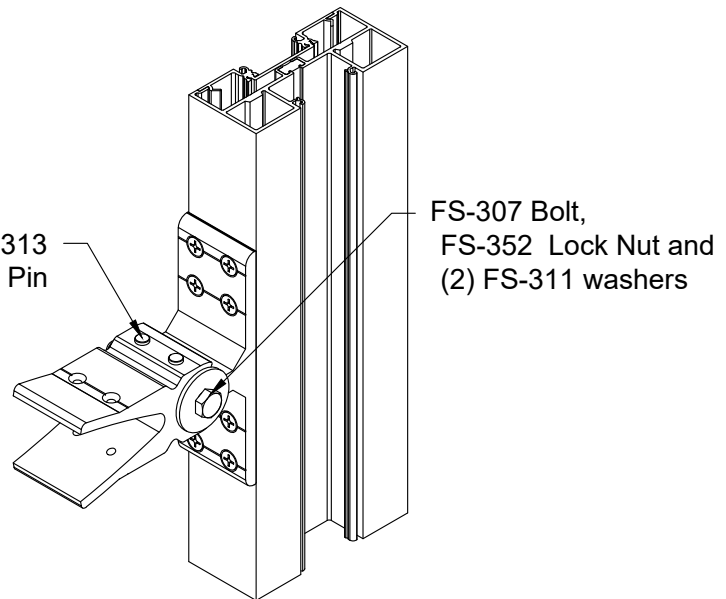

FIGURE 24

FS-307 Bolt,
FS-352 Lock Nut and
(2) FS-311 washers

See page 25 for installation of anchors at project specific angles

SOLAR ECLIPSE™ SINGLE BLADE SUNSHADE INSTALLATION MANUAL

2.1 Storefront Horizontal Installation (continued)

- 6) Blades for adjustable sunshades are available in widths from 8" to 14". See parts list at back of manual for extrusion numbers.
- 7) Blades should be spliced at maximum 10 foot or as required based on Engineer's review. See pages 22 thru 24 & 26 for splice information.
- 8) Blades are attached to the SS-208 mounting arm using four (4) FS-148 (#10 x 3/4" UCPFH St. Steel) fasteners. Match drill sunshade blade using #25 (.159"Ø) drill (SEE FIGURE 17)
- 9) Final assembly of Solar Eclipse II is shown in FIGURE 24 & 25 for FG-3621 mullion.
- 10) SolarEclipse II sunshades may be installed on Series 3000 & 6000 Multiplane Center Set and 3000XT and 6000XT Storefront systems. See FIGURES 26, 27 & 28 on page 17 for additional mullions available for the 3000 Multiplane Center Set and the 3000XT systems. Similar installation is available for the 6000 Multiplane Center Set and 6000XT systems. Sunshades should not be installed on the standard mullions such as FG-3495.

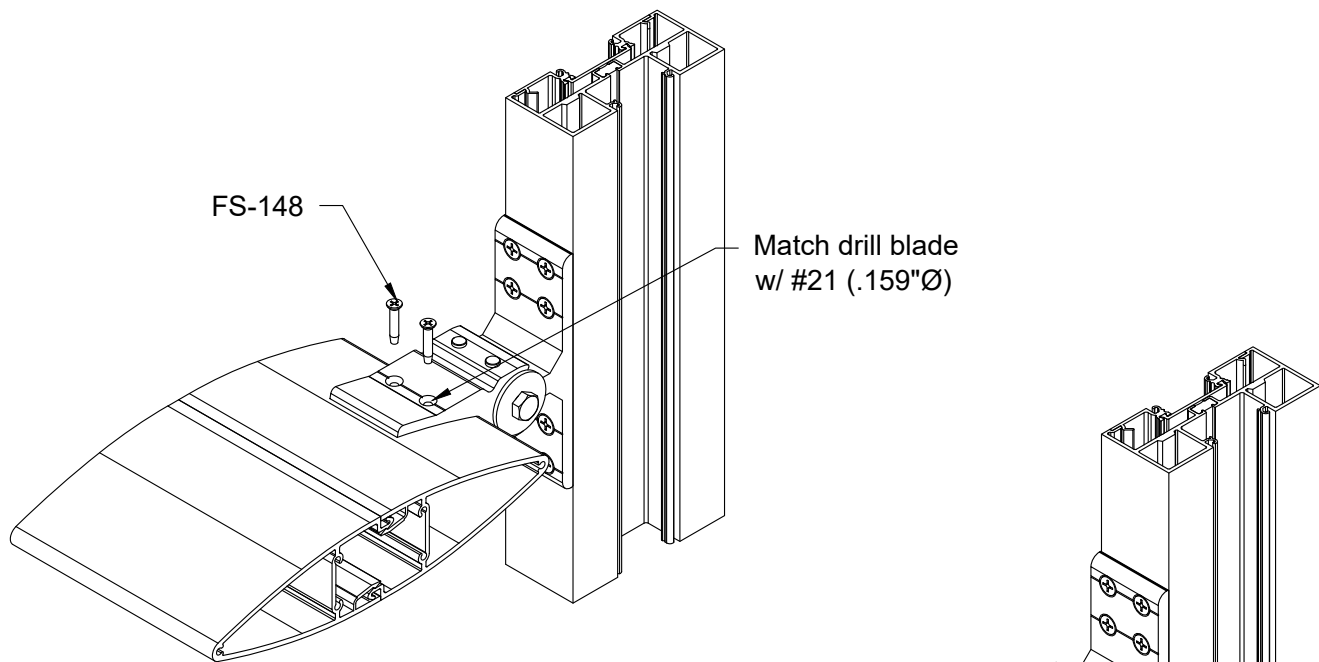

FIGURE 24

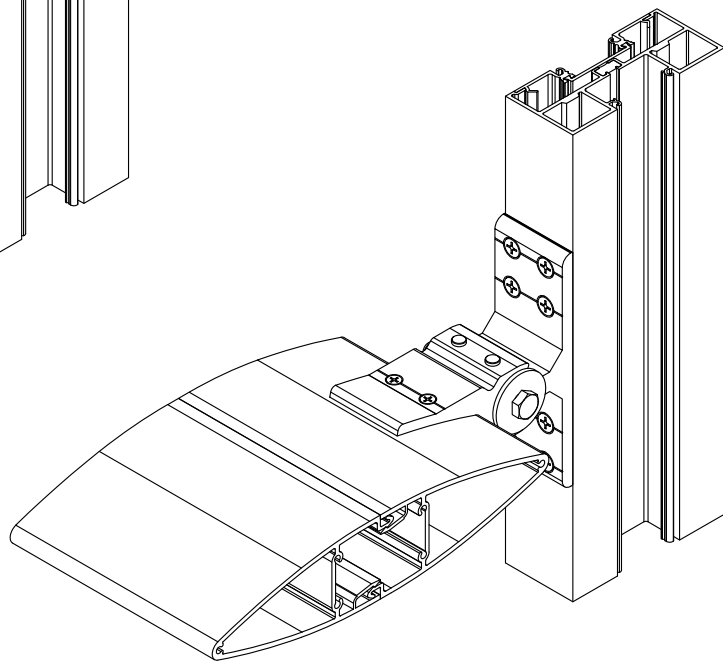

FIGURE 25

SOLAR ECLIPSE™ SINGLE BLADE SUNSHADE INSTALLATION MANUAL

2.1 Storefront Horizontal Installation (continued)

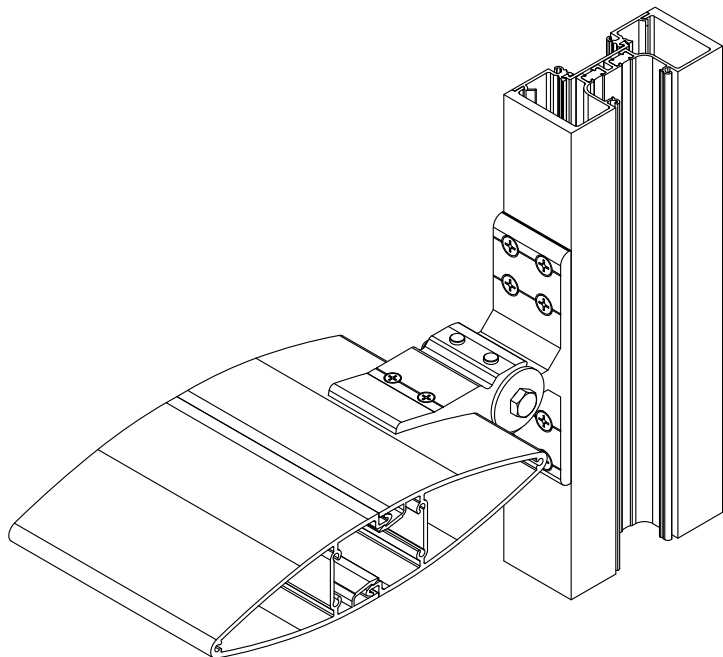

FIGURE 26
3000 Multiplane HD
Mullion

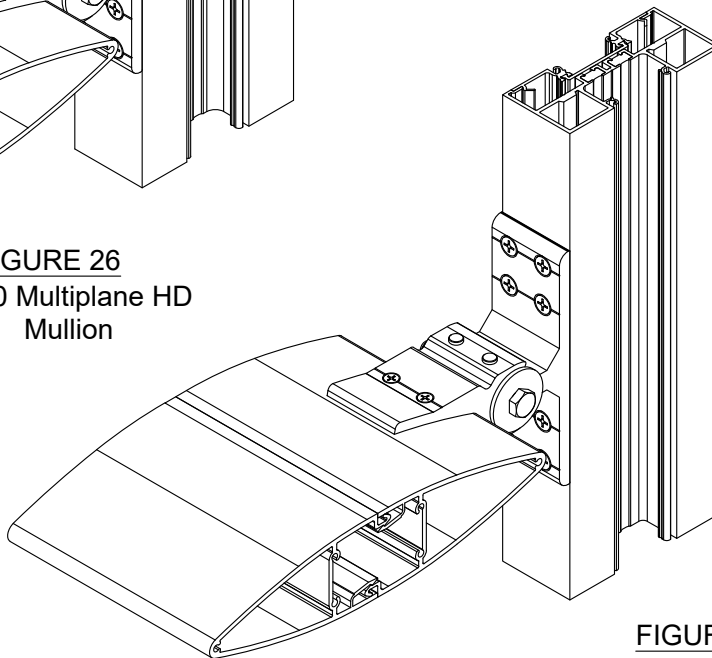

FIGURE 27
3000XT Sunshade
Mullion

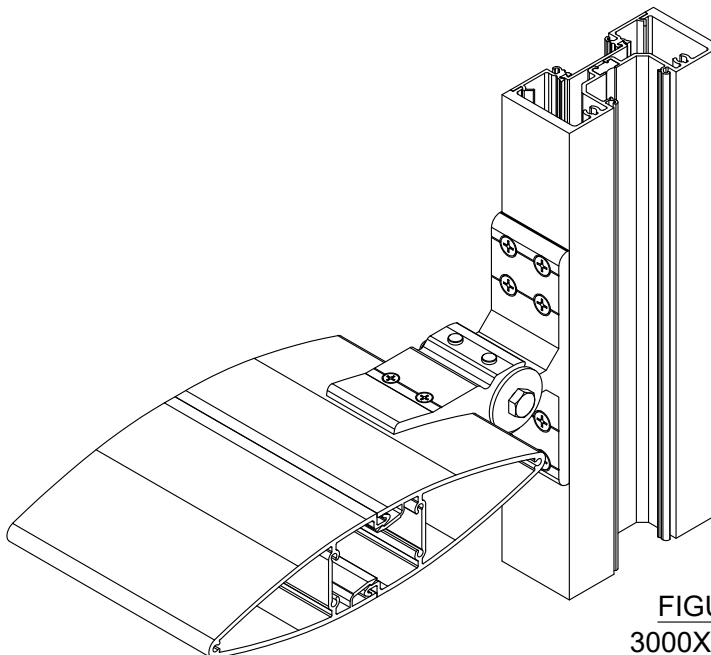

FIGURE 28
3000XT HD Mullion

SOLAR ECLIPSE™ SINGLE BLADE SUNSHADE INSTALLATION MANUAL

2.2 Storefront Vertical Installation

- 1) Drill face of mullion using a #11 (.191" Ø) drill per FIGURE 30 & 31.
- 2) Install anchor onto face of mullion using four FS-147 (1/4"-20 x 3/4" PFH Type F Stainless Steel) fasteners. SEE FIGURE 32

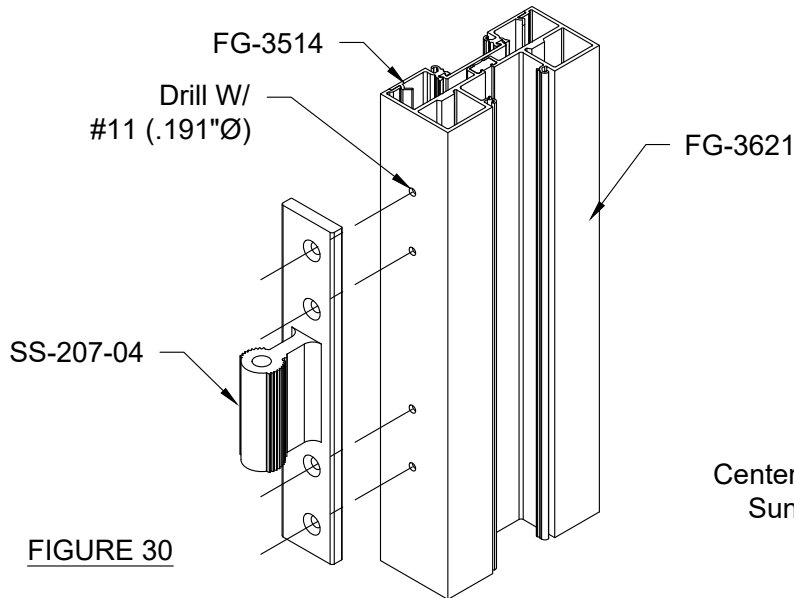

FIGURE 30

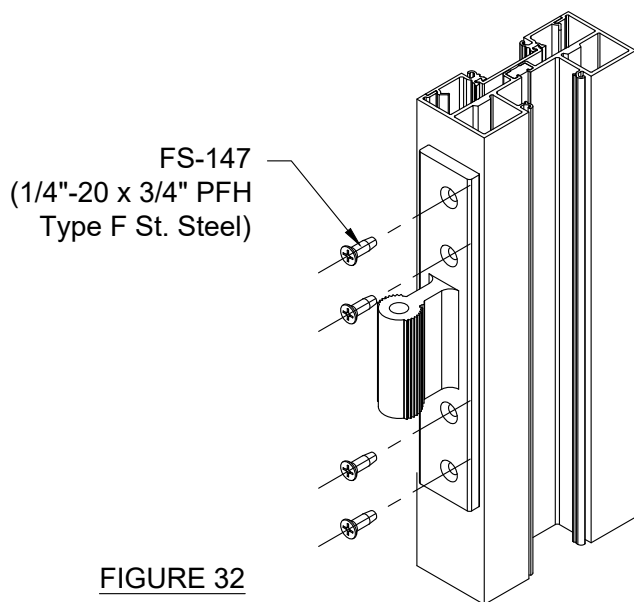

FIGURE 32

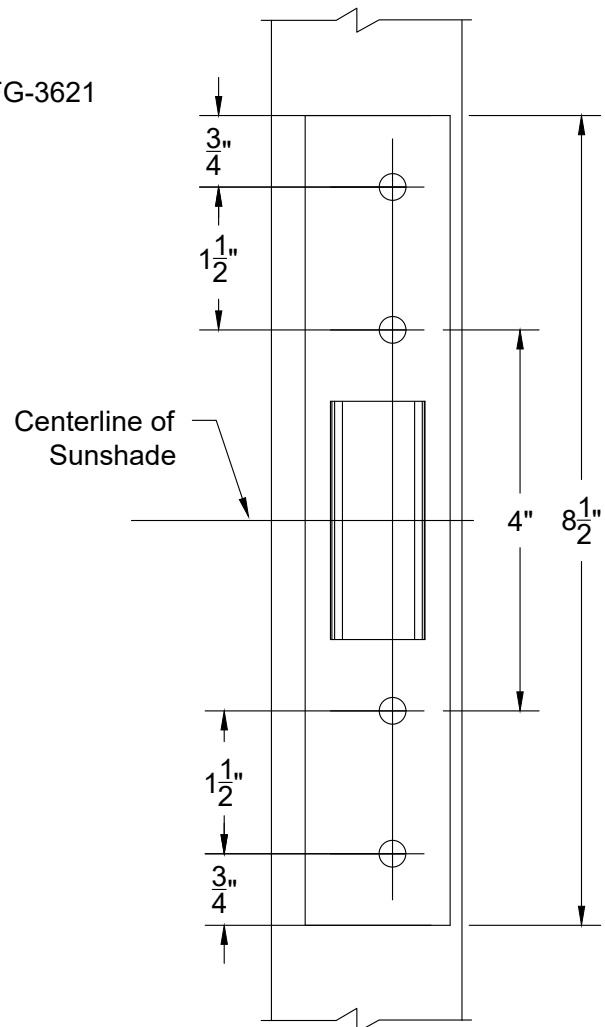

FIGURE 31

Note: SS-207 Anchor is handed and must be installed based on specified blade angle

SOLAR ECLIPSE™ SINGLE BLADE SUNSHADE INSTALLATION MANUAL

2.2 Storefront Vertical Installation (continued)

- 3) Blade angle should have been determined prior to installing the SS-207 anchor. (See page 25 for information on setting blade angle).
- 4) Slide SS-208-01 mounting arm over the previously installed SS-207-04 anchor. Match drill at least two holes through the SS-208 into the SS-207 using #21 (.159" Ø) drill. SEE FIGURE 33
- 5) Insert FS-313 drive pins into mounting arm and drive into anchor. Once pins are installed, bolt assembly together using a FS-308 (3/8"-16 x 3-1/4" Hex Bolt), (2) FS-311 fender washers and a FS-352 lock nut. SEE FIGURE 34

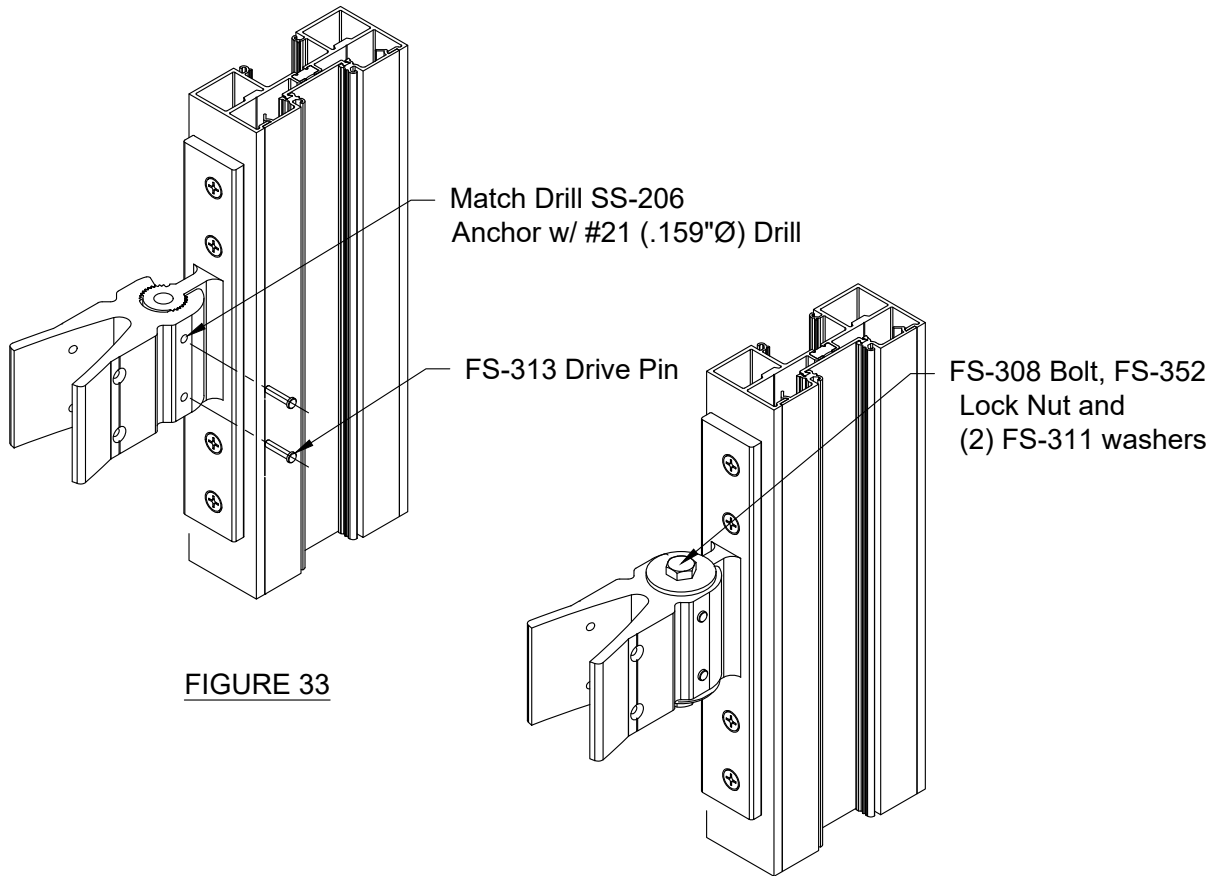

FIGURE 33

FIGURE 34

See page 25 for installation of anchors at project specific angles

SOLAR ECLIPSE™ SINGLE BLADE SUNSHADE INSTALLATION MANUAL

2.2 Storefront Vertical Installation (continued)

- 6) Blades for adjustable sunshades are available in widths from 8" to 14". See parts list at back of manual for extrusion numbers.
- 7) Blades should be spliced at maximum 10 foot or as required based on Engineer's review. See pages 22 thru 24 & 27 for splice information.
- 8) Blades are attached to the SS-208 mounting arm using four (4) FS-148 (#10 x 3/4" UCPFH St.Steel) fasteners. Match drill sunshade blade using #25 (.159"Ø) drill (SEE FIGURE 35)
- 9) Final assembly of Solar Eclipse II is shown in FIGURE 36 for FG-3621 mullion.
- 10) SolarEclipse II sunshades may be installed on Series 3000 & 6000 Multiplane Center Set and 3000XT and 6000XT Storefront systems. See Parts List on page 26 for optional mullions that may be used with the Series 3000 Multiplane and the 3000XT systems. Similar installation is also available for the 6000 Multiplane Center Set and 6000XT systems. Sunshades should not be installed on the standard mullions such as FG-3495.

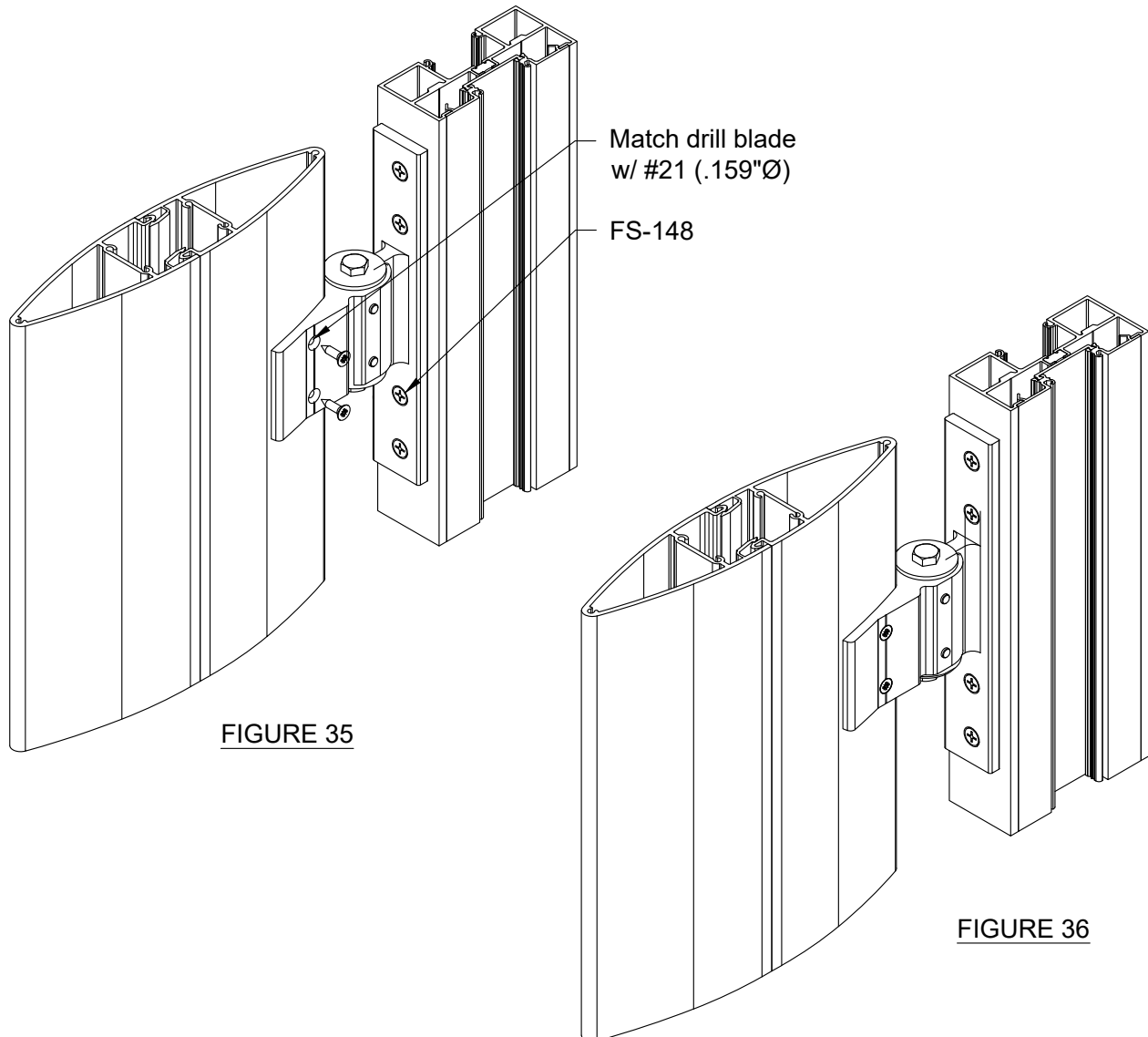

SOLAR ECLIPSE™ SINGLE BLADE SUNSHADE INSTALLATION MANUAL

3.1 Splice Fabrication and Assembly

- 1) Fabricate 2-1/2" sections of sunshade blade for Curtain Walls and 2" Sections for Storefront w/ (2) 7/32" (.218" Ø) holes as shown in FIGURE 37.
- 2) Insert splice sleeve into sunshade blade (SEE FIGURE 38). The splice will flush at one edge for jamb conditions (SEE FIGURE 39) and be set at equal distances on each side for intermediate mullions (SEE FIGURE 40). Attach splice to blade using (2) FS-322 (#12-14 x 1" HWH Drill-Flex) fasteners. SEE FIGURE 38

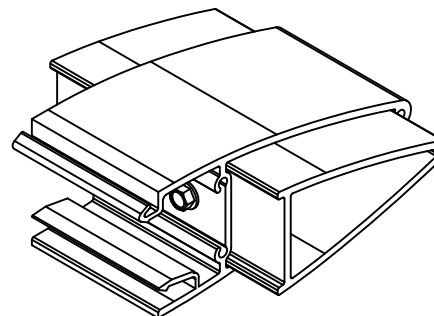
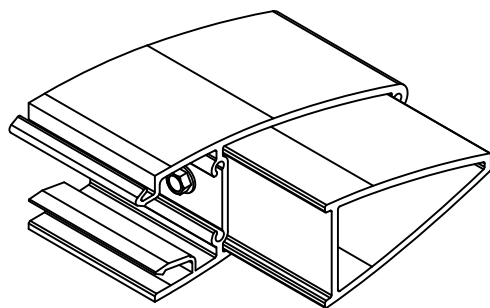
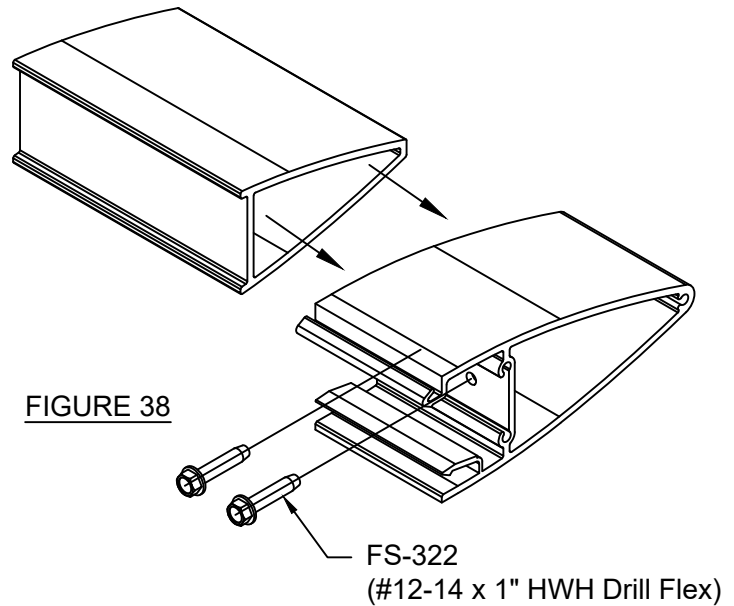
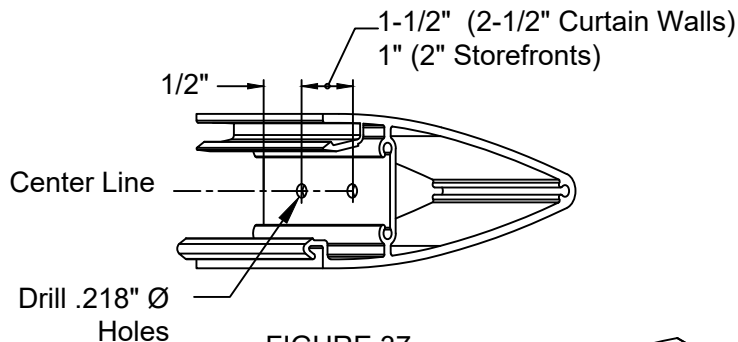

SOLAR ECLIPSE™ SINGLE BLADE SUNSHADE INSTALLATION MANUAL

3.1 Splice Fabrication and Assembly (continued)

- 3) Assemble the two sections of the blade and splice together, then attach a connector plate on each side of intermediate (SEE FIGURE 41 & 42) and splice side of jamb (SEE FIGURE 43, page 23). Connector plate will attach to blade using (4) FS-313 fasteners. See parts list for connector plate part number for each blade assembly.

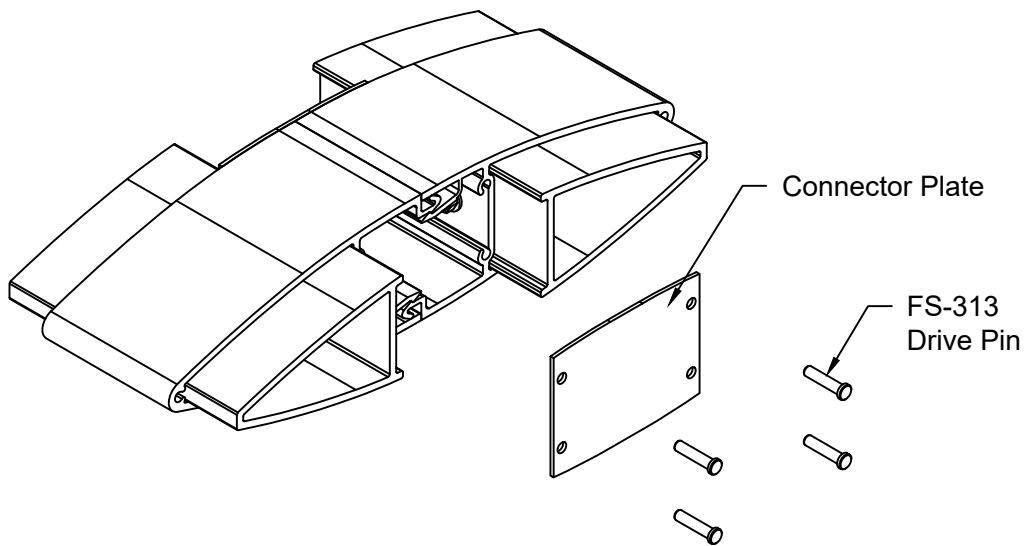

FIGURE 41

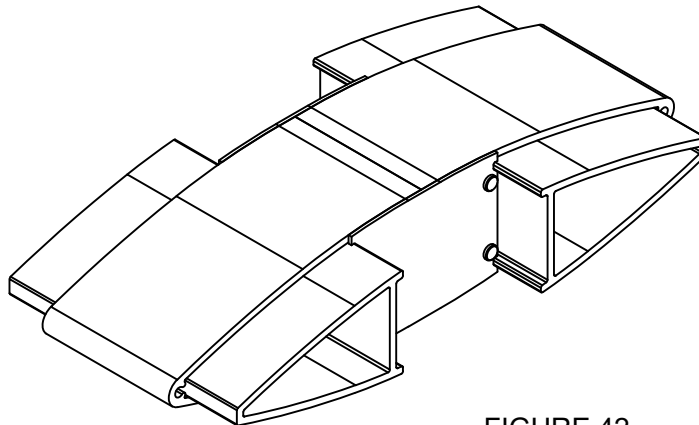

FIGURE 42

SOLAR ECLIPSE™ SINGLE BLADE SUNSHADE INSTALLATION MANUAL

3.1 Splice Fabrication and Assembly (continued)

- 4) Jamb splice assemblies will get an end cap attached to jamb side using (2) FS-313 drive pins. See Parts List for end cap for each standard blade assembly. SEE FIGURE 44

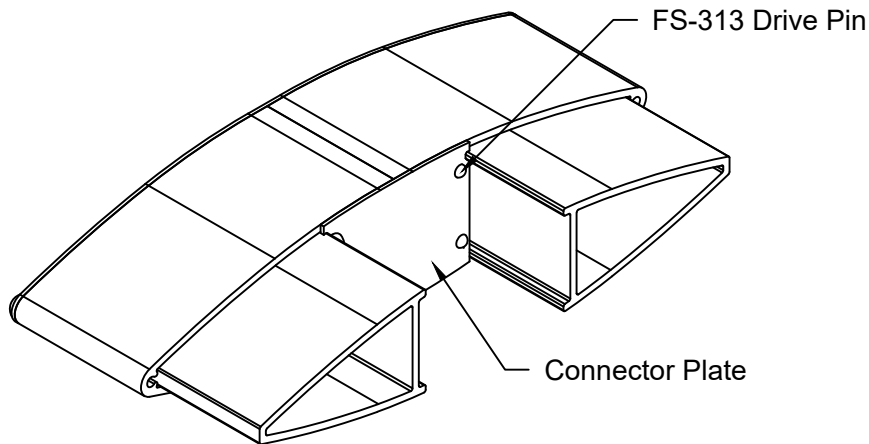

FIGURE 43

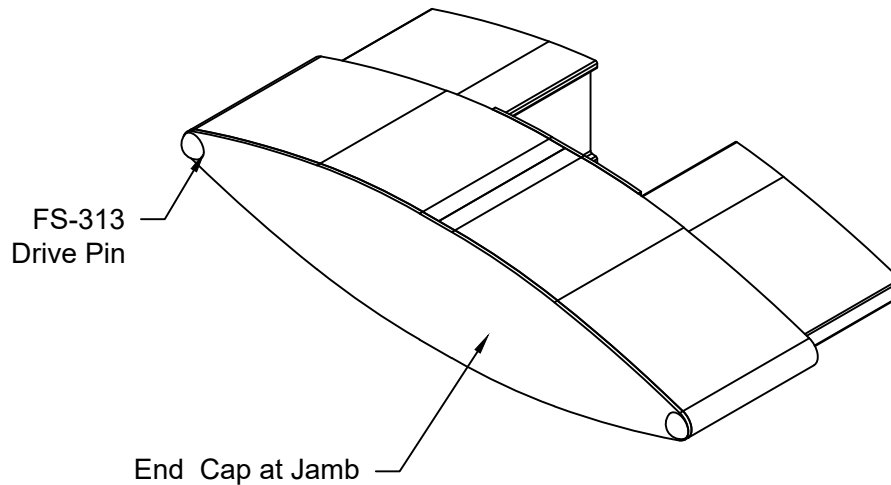

FIGURE 44

SOLAR ECLIPSE™ SINGLE BLADE SUNSHADE INSTALLATION MANUAL

3.1 Splice Fabrication and Assembly (continued)

- 5) When using a solid blade like the SS-1162, connector plates are not required. Splice will be installed similar to shown on page 21. Drill #17 (.173"Ø) holes in blade as shown in FIGURE 45 and countersink for #8 flat head. Fasten splice to the sunshade blade using (4) FS-25 (#8 x 1/2" pfh Tek St. Steel) fasteners on top side of blade. SEE FIGURE 45.
- 6) Assemble each blade section and attach a connector plate to each end using FS-313 Drive Pins. Maximum length of each section will be approximately 10 foot or per Engineer's review. There should be only one rigid mount at center of each blade section with splice at each end. SEE FIGURE 46.

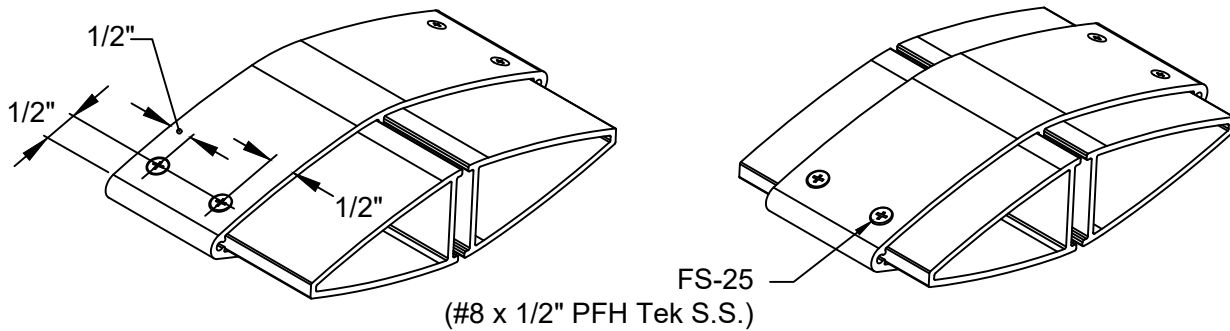

FIGURE 45

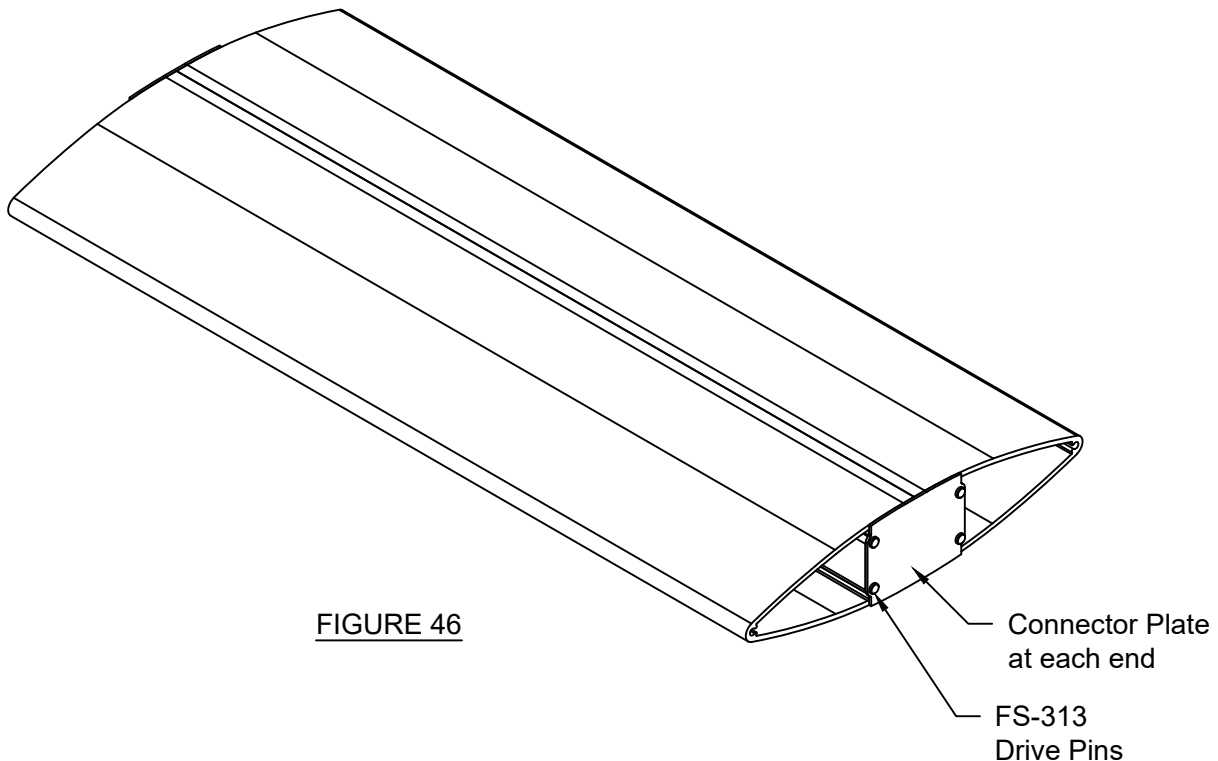

FIGURE 46

SOLAR ECLIPSE™ SINGLE BLADE SUNSHADE INSTALLATION MANUAL

4.1 Sunshade Anchor and Blade Angle Instructions

- 1) OBE's Solar Eclipse Single Blade sunshade may be set at angles of zero, 5, 10, 15, 20, 25, 30 and 35 degree angles. The mull anchor is handed so must be installed based on the specified blade angle for the project. SEE FIGURE 47
- 2) When installing at zero, 5, 15, 25 and 35 degrees the (ID) mark on the SS-205 or SS-206 anchor will be located on the top side of the anchor. SEE FIGURE 48
- 3) When installing at 10, 20 or 30 degrees the (ID) mark will be on the bottom of the SS-205 or SS-206 anchor. SEE FIGURE 49

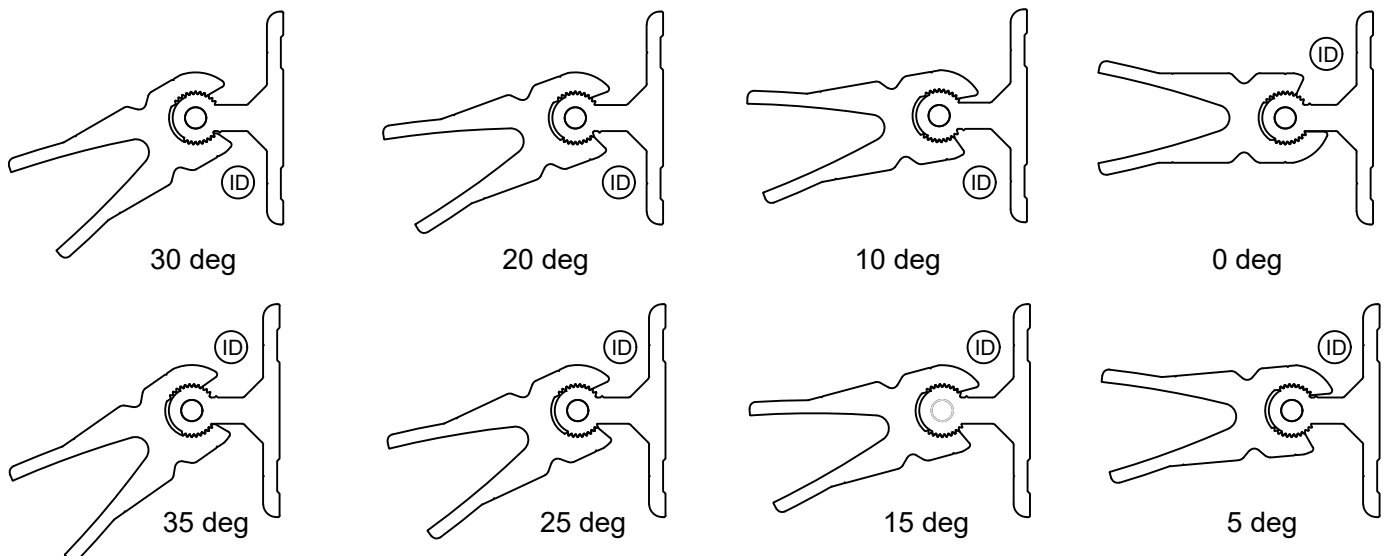
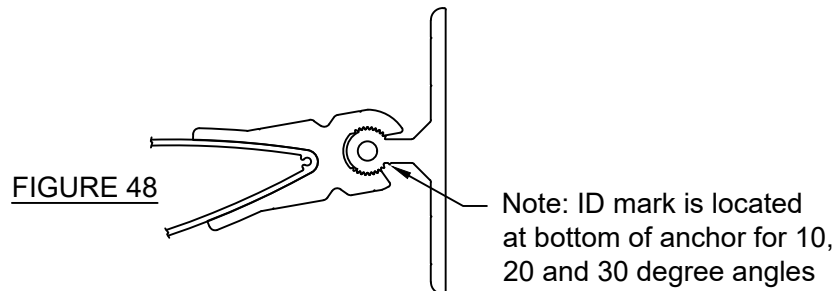
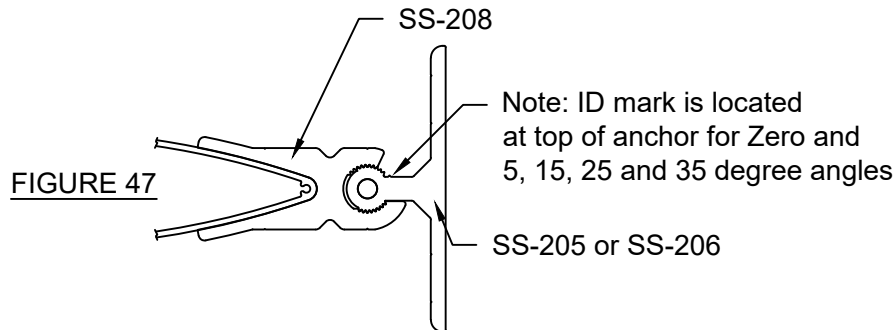

FIGURE 49

SOLAR ECLIPSE™ SINGLE BLADE SUNSHADE INSTALLATION MANUAL

5.1 Sunshade Horizontal Layout

- 1) When installing the SolarEclipse Single Blade sun control system, the blades will only be attached to one mullion per span as shown below. There will be a splice connector installation at all jambs and every other vertical mullion. Corner must be engineered per project, but in most installation the adjacent mullion will require an anchor attached to the blade and blade will cantilever across the corner with a joint at each corner. (SEE FIGURE 50) In the case of an long span, a SS-207 anchor may be attached to the horizontal on Reliance and Reliance -TC Type I & II curtain walls to anchor the blade to the wall. (SEE FIGURE 51)

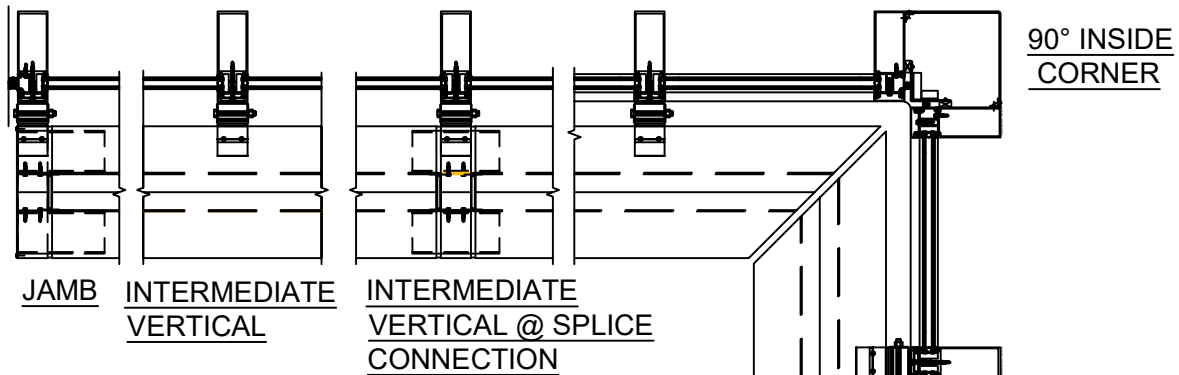

FIGURE 50

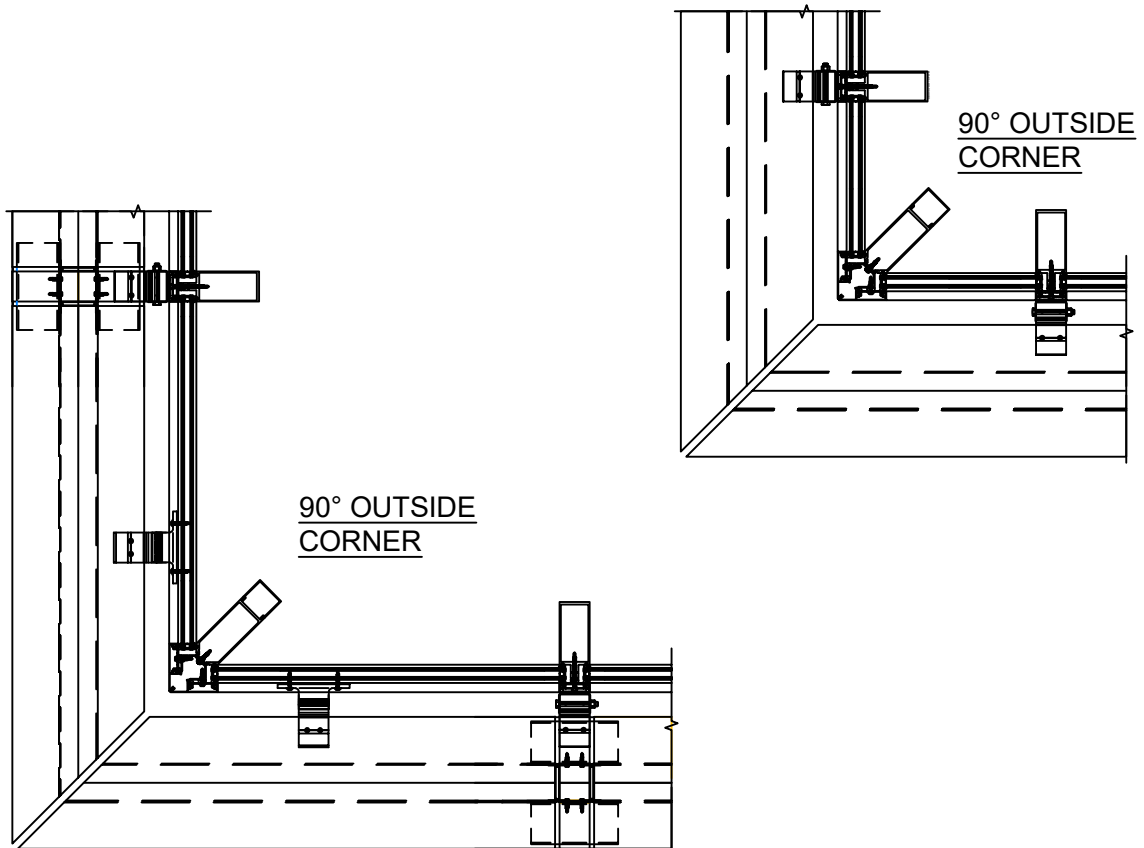

FIGURE 51

SOLAR ECLIPSE™ SINGLE BLADE SUNSHADE INSTALLATION MANUAL

5.2 Sunshade Vertical Layout

- 1) When installing the Solar Eclipse Single Blade sun control system in a vertical application, there will be one sunshade splice connection at each mullion splice above the first level. NOTE: One single blade cannot be hard anchored across both sides of the vertical mullion's splice (SEE FIGURE 52). Anchor locations and Splice Joint size will be determined by thermal and live load movement based on project Engineer's review.

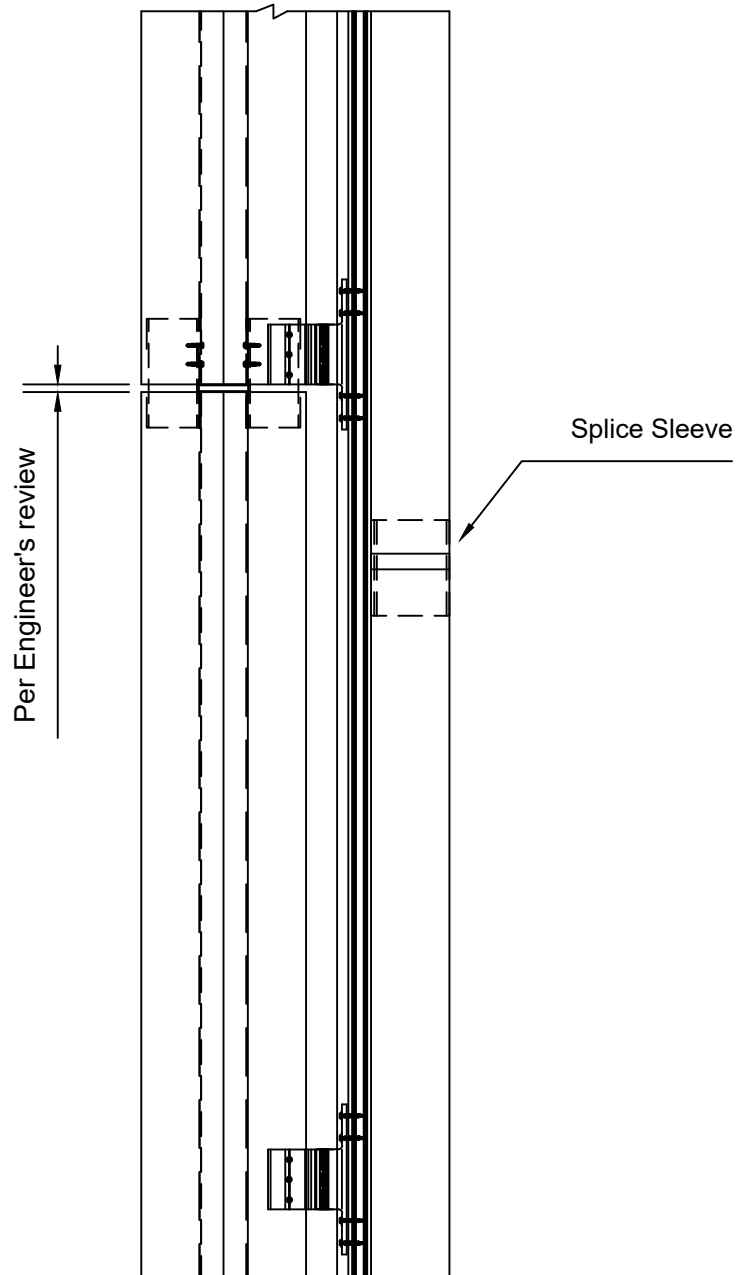
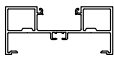

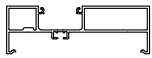





FIGURE 52



SOLAR ECLIPSE™ SINGLE BLADE SUNSHADE INSTALLATION MANUAL

PARTS LIST





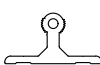
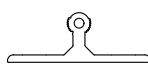

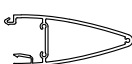
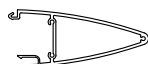

Sunshade Mullion Extrusions

ITEM	DESCRIPTION
 FG-3621	Series 3000 Multiplane Center Set
 FG-3624	Series 3000XT
 FG-6621	Series 6000 Multiplane Center Set
 FG-6624	Series 6000XT
 WW-410/510/800	Reliance Mullion
 WW-466/566	Reliance-TC Type I & Reliance-TC IG Mullion
 AW-430/530	Reliance-TC Type II Mullion

Sunshade Anchors & Mounting Arm

ITEM	DESCRIPTION
 SS-205	Reliance-SSG Anchor
 SS-206	Horizontal Anchor
 SS-207	Vertical Anchor
 SS-208	Horizontal or Vertical Mounting Arm









Sunshade Blade & Splice Extrusions

ITEM	DESCRIPTION
 SS-1162	8" Blade
 SS-1201	10" Blade (2 per assembly)
 SS-1172	11" Blade (2 per assembly)
 SS-1163	12" Blade (2 per assembly)
 SS-1164	14" Blade (2 per assembly)
 SS-1207-01	8" Blade Splice (2 per assembly)
 SS-1208-01	10" Blade Splice (2 per assembly)
 SS-1209-01	11" Blade Splice (2 per assembly)
 SS-1210-01	12" Blade Splice (2 per assembly)
 SS-1211-01	14" Blade Splice (2 per assembly)









SOLAR ECLIPSE™ SINGLE BLADE SUNSHADE INSTALLATION MANUAL

PARTS LIST

Sunshade End Caps-Connector Plates

ITEM	DESCRIPTION
 SS-EC-1	8" End Cap
 SS-EC-2	10" End Cap
 SS-EC-3	11" End Cap
 SS-EC-4	12" End Cap
 SS-EC-5	14" End Cap
 SS-CP-2	10" Connector Plate
 SS-CP-3	11" Connector Plate
 SS-CP-4	12" Connector Plate
 SS-CP-5	14" Connector Plate

Fasteners

ITEM	DESCRIPTION
 FS-25	#8 x 1/2" PFHUC Stainless Steel Tek for 8" Splice
 FS-313	Drive Pin for Connector Plates, End Caps & Angle Set Screw
 FS-312	1/4"-20 x 1-1/2" HWH Bi-Flex for TC Corner Anchor Installation
 FS-316	1/4"-20 x 2" HWH Drill Flex for Reliance Corner Anchor Installation
 FS-306	1/4"-20 x 3" HWH Bi-Flex for Anchor Installation at Mullions
 FS-322	#12-14 x 1" HWH Drill Flex for Splice Assembly
 FS-147	1/4"-20 x 3/4" PFH F Pt. Stainless Steel for Storefront Anchor Installation
 FS-148	#10 x 3/4" PFHUC Stainless Steel for Blade Attachment

SOLAR ECLIPSE™ SINGLE BLADE SUNSHADE INSTALLATION MANUAL

ANCHOR KITS

The hardware kits listed below are provided for simplicity in ordering the required items for each application. Hardware kits contain anchors, mounting arms and fastener hardware needed to install 10 (ten) anchors & mounting arms.

These kits are available in all standard OBE finishes. Refer to table below for MRP numbers.

Hardware for splices, end caps and connector plates will be ordered separately---individually or in bulk packages---as needed for project.

System & Blade Orientation	Class I Clear Anodize	Class II Clear Anodize	Light Bronze Anodize	Medium Bronze Anodize	Dark Bronze Anodize	Black Anodize	Cham-pagne Anodize	Custom Anodize	OBE Std White Paint	OBE 70% Kynar	All Other Paint
Reliance Horizontal Blade	37072	37071	37077	37079	37080	37070	37076	37075	37078	37073	37074
Reliance Vertical Blade	37168	37167	37173	37175	37176	37166	37172	37171	37174	37169	37170
Reliance w/ SSG Verticals (Horiz. blade only)	37191	37190	37196	37198	37199	37189	37195	37194	37197	37192	37193
Reliance Horiz. Blade @ 90° Outside Corner	37061	37060	37066	37068	37069	37059	37065	37064	37067	37062	37063
Reliance Vertical Blade @ 90° Outside Corner	37206	37205	37211	37213	37214	37204	37210	37209	37212	37207	37208
Rel. TC Type I/TC IG Horiz. Blade Left Hand*	37145	37144	37150	37152	37153	37143	37149	37148	37151	37146	37147
Rel. TC Type I/TC IG Horiz. Blade Right Hand*	37134	37133	37139	37141	37142	37132	37138	37137	37140	37135	37136
Rel. TC Type I/TC IG Vert. Blade Left Hand*	37123	37122	37128	37130	37131	37121	37127	37126	37129	37124	37125
Rel. TC Type I/TC IG Vert. Blade Right Hand*	37112	37111	37117	37119	37120	37110	37116	37115	37118	37113	37114
Rel. TC Type II Horiz. Blade	37090	37089	37095	37097	37098	37088	37094	37093	37096	37091	37092
Rel. TC Type II Vert. Blade	37179	37178	37184	37187	37188	37177	37183	37182	37186	37180	37181
Rel. TC/TC IG Horiz. Blade @ 90° Outside Corner	37101	37100	37106	37108	37109	37099	37105	37104	37107	37102	37103
Rel. TC/TC IG Vert. Blade @ 90° Outside Corner	37217	37216	37222	37224	37225	37215	37221	37220	37223	37218	37219
Series 3000/6000 MultiPlane (Center Set) / Series 3000/6000XT Horiz. Blade	37050	37049	37055	37057	37058	37048	37054	37053	37056	37051	37052
Series 3000/6000 MultiPlane (Center Set) / Series 3000/6000XT Vert. Blade	37156	37155	37161	37163	37164	37154	37160	37159	37162	37157	37158

*Note: Because the anchor attachment for Reliance-TC Type I & Reliance-TC IG is offset from center, the anchor cannot be simply flipped like other systems to access all available blade set angles. For this reason, these systems require right and left handed versions and care must be taken when ordering. Refer to the installation manual or web details and cross reference with this chart to determine the proper kit for desired application, set angle and finish.

All Reliance-TC and TCIG systems use the same outside corner and the attachment is centered, so handed anchors are not needed for corner applications using these systems.

May 2020

Phone: 1-866-OLDCASTLE (653-2278)

Web: www.obe.com