

USE OF GASKETS
 FOR 5/16" (8mm) GLASS: USE ONE THICK GASKET & ONE THIN GASKET ON EACH SIDE
 FOR 3/8" (10mm) GLASS: USE ONE THICK GASKET ON EACH SIDE

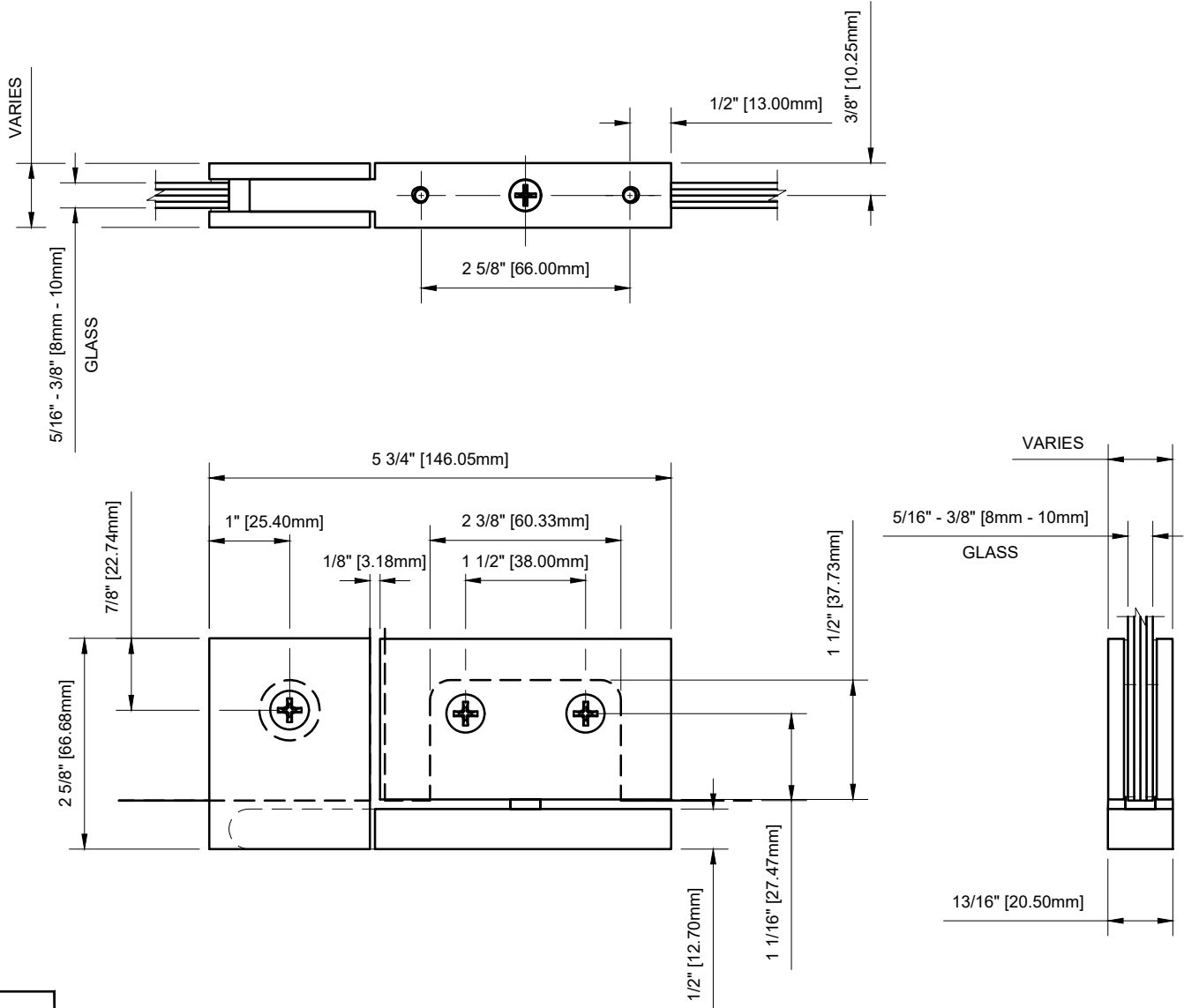

CATALOG NUMBER	FINISH
CAR07CH	CHROME
CAR07BR	BRASS
CAR07ORB	OIL RUBBED BRONZE
CAR07BN	BRUSHED NICKEL
CAR07PN	POLISHED NICKEL
CAR07SC	SATIN CHROME
CAR07SN	SATIN NICKEL

CAR07XX - CRL CARDIFF SERIES TOP OR BOTTOM MOUNT PIVOT HINGE

DATE: 1/7/19
 SCALE: 6"=1'-0"
 DRAWN BY: VM

DESCRIPTION: CRL CAR07_—
 CARDIFF SERIES
 TOP OR BOTTOM MOUNT PIVOT HINGE

C.R. LAURENCE CO., ARCHITECTURAL PRODUCTS
 2503 E. Vernon Avenue, Los Angeles, C.A. 90058-1897
 PH (800)-421-6144 FX: 800-587-7301 www.crlaurence.com

CRL
 A CRH COMPANY

USE OF GASKETS

FOR 5/16" (8mm) GLASS: USE ONE THICK GASKET & ONE THIN GASKET ON EACH SIDE
 FOR 3/8" (10mm) GLASS: USE ONE THICK GASKET ON EACH SIDE

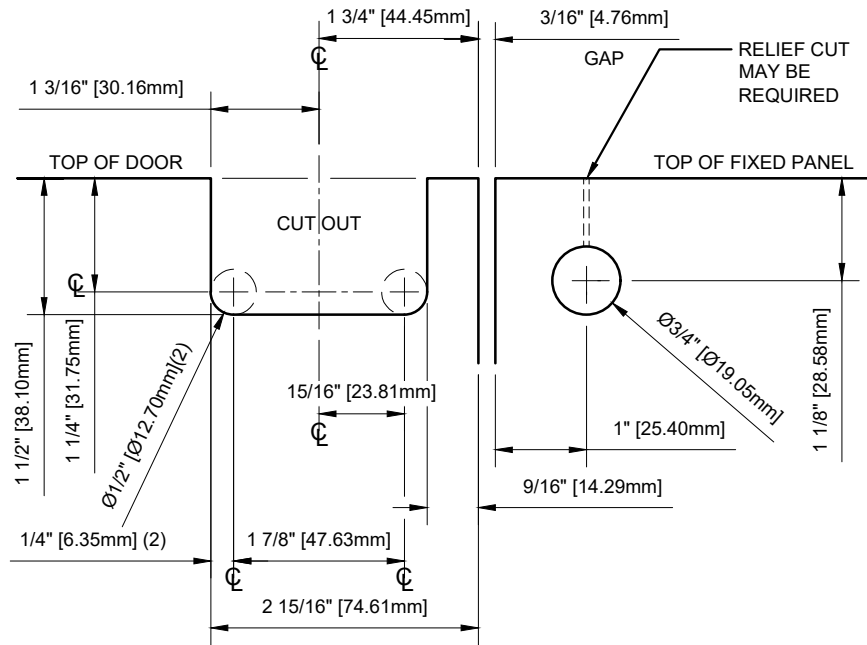

EDGE MOUNT PREFERRED METHOD

CAR07XX - CRL CARDIFF GLASS TEMPLATE

CATALOG NUMBER	FINISH
CAR07CH	CHROME
CAR07BR	BRASS
CAR07ORB	OIL RUBBED BRONZE
CAR07BN	BRUSHED NICKEL
CAR07PN	POLISHED NICKEL
CAR07SC	SATIN CHROME
CAR07SN	SATIN NICKEL

DATE: 1/7/19
 SCALE: 6"=1'-0"
 DRAWN BY: VM

DESCRIPTION: CRL CAR07_—
 CARDIFF SERIES
 TOP OR BOTTOM MOUNT PIVOT HINGE

C.R. LAURENCE CO. ARCHITECTURAL PRODUCTS
 2503 E. Vernon Avenue, Los Angeles, C.A 90058-1897
 PH (800)-421-6144 FX: 800-587-7501 www.crlaurence.com



USE OF GASKETS

FOR 5/16" (8mm) GLASS: USE ONE THICK GASKET & ONE THIN GASKET ON EACH SIDE
 FOR 3/8" (10mm) GLASS: USE ONE THICK GASKET ON EACH SIDE

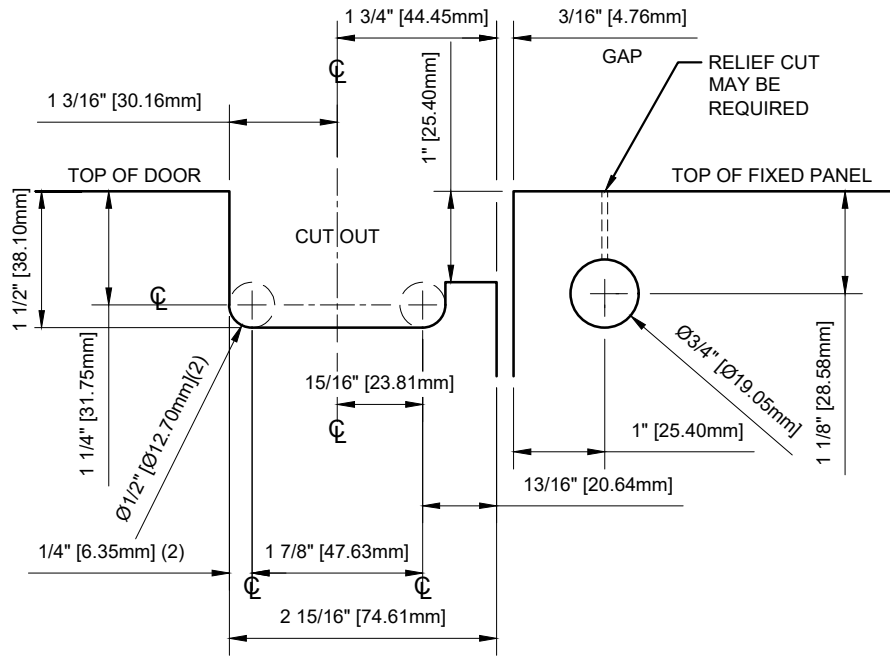

EDGE MOUNT ALTERNATE METHOD

CAR07XX - CRL CARDIFF GLASS TEMPLATE

CATALOG NUMBER	FINISH
CAR07CH	CHROME
CAR07BR	BRASS
CAR07ORB	OIL RUBBED BRONZE
CAR07BN	BRUSHED NICKEL
CAR07PN	POLISHED NICKEL
CAR07SC	SATIN CHROME
CAR07SN	SATIN NICKEL

DATE: 1/7/19
 SCALE: 6"=1'-0"
 DRAWN BY: VM

DESCRIPTION: CRL CAR07_—
 CARDIFF SERIES
 TOP OR BOTTOM MOUNT PIVOT HINGE

C.R. LAURENCE CO. ARCHITECTURAL PRODUCTS
 2503 E. Vernon Avenue, Los Angeles, C.A. 90008-1897
 PH (800)-421-6144 FX: 800-587-7301 www.crlaurence.com



USE OF GASKETS

FOR 5/16" (8mm) GLASS: USE ONE THICK GASKET & ONE THIN GASKET ON EACH SIDE
 FOR 3/8" (10mm) GLASS: USE ONE THICK GASKET ON EACH SIDE

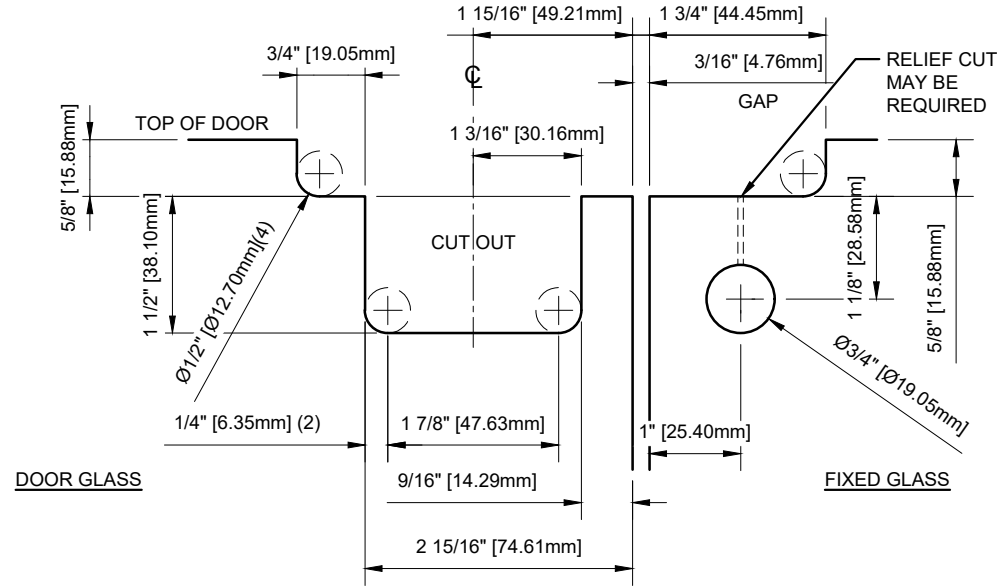

TOP FLUSH MOUNT METHOD

CAR07XX - CRL CARDIFF GLASS TEMPLATE

CATALOG NUMBER	FINISH
CAR07CH	CHROME
CAR07BR	BRASS
CAR07ORB	OIL RUBBED BRONZE
CAR07BN	BRUSHED NICKEL
CAR07PN	POLISHED NICKEL
CAR07SC	SATIN CHROME
CAR07SN	SATIN NICKEL

DATE: 1/7/19
 SCALE: 6"=1'-0"
 DRAWN BY: VM

DESCRIPTION: CRL CAR07_—
 CARDIFF SERIES
 TOP OR BOTTOM MOUNT PIVOT HINGE

C.R. LAURENCE CO. ARCHITECTURAL PRODUCTS
 2503 E. Vernon Avenue, Los Angeles, C.A 90058-1897
 PH (800)-421-6144 FX: 800-587-7301 www.crlaurence.com



USE OF GASKETS

FOR 5/16" (8mm) GLASS: USE ONE THICK GASKET & ONE THIN GASKET ON EACH SIDE
 FOR 3/8" (10mm) GLASS: USE ONE THICK GASKET ON EACH SIDE

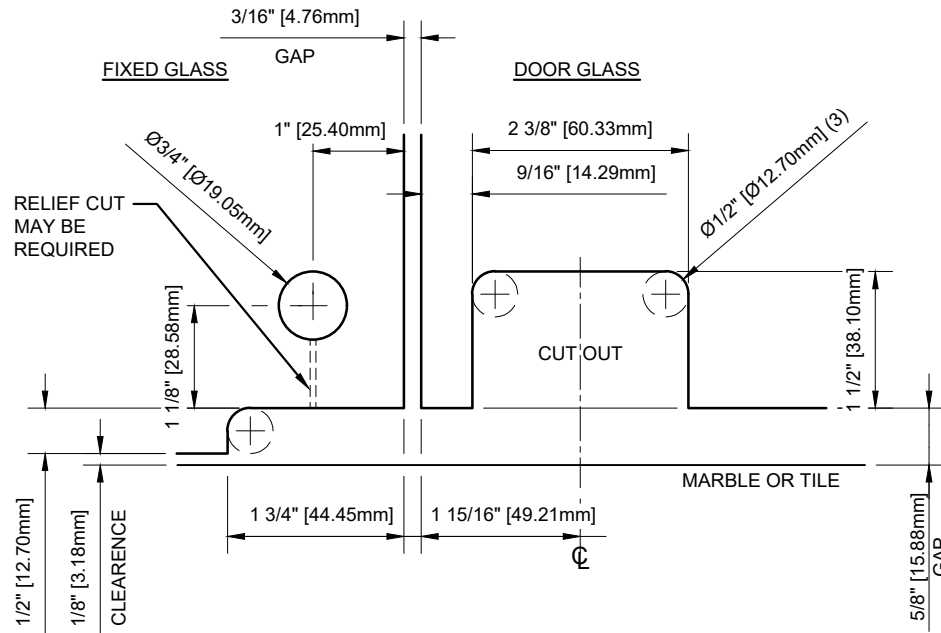

BOTTOM MOUNT METHOD

CAR07XX - CRL CARDIFF GLASS TEMPLATE

CATALOG NUMBER	FINISH
CAR07CH	CHROME
CAR07BR	BRASS
CAR07ORB	OIL RUBBED BRONZE
CAR07BN	BRUSHED NICKEL
CAR07PN	POLISHED NICKEL
CAR07SC	SATIN CHROME
CAR07SN	SATIN NICKEL

DATE: 1/7/19
 SCALE: 6"=1'-0"
 DRAWN BY: VM

DESCRIPTION: CRL CAR07_—
 CARDIFF SERIES
 TOP OR BOTTOM MOUNT PIVOT HINGE

C.R. LAURENCE CO. ARCHITECTURAL PRODUCTS
 2503 E. Vernon Avenue, Los Angeles, C.A. 90008-1897
 PH (800)-421-6144 FX: 800-587-7301 www.crlaurence.com

