

**NFRC 102-2010 THERMAL PERFORMANCE
TEST REPORT**

Rendered to:

US ALUMINUM INC., DIVISION OF CR LAURENCE CO., INC.

SERIES/MODEL: FT 451 Storefront - Inside Set

TYPE: Glazed Wall Systems (Site-built)

Summary of Results	
Standardized Thermal Transmittance (U-Factor)	0.42
Unit Size	79" x 79" (2007 mm x 2007 mm) (Model Size)
Layer 1	1/4" Clear
Gap 1	0.50" Gap, Super Spacer Standard (OF-S), 100% Air-Filled*
Layer 2	1/4" AGC Comfort TiAC36 LowE (e=0.034*, #3)

Reference must be made to Report No. C2485.01-201-46, dated 11/29/12 for complete test specimen description and data.

NFRC 102-2010 THERMAL PERFORMANCE TEST REPORT

Rendered to:

US ALUMINUM INC., DIVISION OF CR LAURENCE CO., INC.
200 Singleton Drive
Waxahachie, Texas 75165

Report Number: C2485.01-201-46
Test Date: 09/12/12
Report Date: 11/29/12
Test Record Retention Date: 09/12/16

Test Sample Identification:

Series/Model: FT 451 Storefront - Inside Set

Type: Glazed Wall Systems (Site-built)

Overall Size: 79" x 79" (2007 mm x 2007 mm) (Model Size)

NFRC Standard Size: 78.7" x 78.7" (2000 mm wide x 2000 mm high)

Test Sample Submitted by: Client

Test Sample Submitted for: Validation for Initial Certification (Production Line Unit)
& Plant Qualification

Test Procedure: U-factor tests were performed in a Guarded Hot Box in accordance with NFRC 102-2010, *Procedure for Measuring the Steady-State Thermal Transmittance of Fenestration Systems*.

Test Results Summary:

Standardized U-factor (U_{st}): 0.42 Btu/hr·ft²·F CTS Method

Test Sample Description:

CONSTRUCTION	Frame
Size (in.)	79 x 79
Daylight Opening (in.)	36-1/2 x 75 (x2)
CORNERS	Square Cut
Fasteners	Screws
Sealant	No
MATERIAL	AT (0.21")
Color Exterior	Gray
Finish Exterior	Anodized
Color Interior	Gray
Finish Interior	Anodized
GLAZING METHOD	Exterior

Glazing Information:

Layer 1	1/4" Clear
Gap 1	0.50" Gap, Super Spacer Standard (OF-S), 100% Air-Filled*
Layer 2	1/4" AGC Comfort TiAC36 LowE (e=0.034*, #3)
Gas Fill Method	N/A

**Stated per Client/Manufacturer*

N/A Non-Applicable

See Description Table Abbreviations

Test Sample Description: (Continued)

COMPONENTS		
Type	Quantity	Location
WEATHERSTRIP		
No weatherstrip		
HARDWARE		
No hardware		
DRAINAGE		
No drainage		

Thermal Transmittance (U-factor)

Measured Test Data

Heat Flows

1. Total Measured Input into Metering Box (Q_{total})	1446.87 Btu/hr
2. Surround Panel Heat Flow (Q_{sp})	58.76 Btu/hr
3. Surround Panel Thickness	5.00 inches
4. Surround Panel Conductance	0.0354 Btu/hr·ft ² ·F
5. Metering Box Wall Heat Flow (Q_{mb})	52.99 Btu/hr
6. EMF vs Heat Flow Equation (equivalent information)	0.0201*EMF + 27.910
7. Flanking Loss Heat Flow (Q_{fl})	-6.23 Btu/hr
8. Net Specimen Heat Loss (Q_s)	1341.35 Btu/hr

Areas

1. Test Specimen Projected Area (A_s)	43.34 ft ²
2. Test Specimen Interior Total (3-D) Surface Area (A_h)	51.63 ft ²
3. Test Specimen Exterior Total (3-D) Surface Area (A_c)	58.51 ft ²
4. Metering Box Opening Area (A_{mb})	68.75 ft ²
5. Metering Box Baffle Area (A_{b1})	60.57 ft ²
6. Surround Panel Interior Exposed Area (A_{sp})	25.41 ft ²

Test Conditions

1. Average Metering Room Air Temperature (t_h)	69.80 F
2. Average Cold Side Air Temperature (t_c)	-0.41 F
3. Average Guard/Environmental Air Temperature	71.00 F
4. Metering Room Average Relative Humidity	0.54 %
5. Metering Room Maximum Relative Humidity	0.93 %
6. Metering Room Minimum Relative Humidity	0.19 %
7. Measured Cold Side Wind Velocity (Perpendicular Flow)	14.54 mph
8. Measured Static Pressure Difference Across Test Specimen	0.00" ± 0.04"H ₂ O

Average Surface Temperatures

1. Metering Room Surround Panel	65.52 F
2. Cold Side Surround Panel	0.19 F

Results

1. Thermal Transmittance of Test Specimen (U_s)	0.44 Btu/hr·ft ² ·F
2. Standardized Thermal Transmittance of Test Specimen (U_{st})	0.42 Btu/hr·ft ² ·F

Thermal Transmittance (U-factor)

Calculated Test Data

CTS Method

1. Warm Side Emittance of Glass (e_i)	0.84
2. Cold Side Emittance of Glass	0.84
3. Warm Side Frame Emittance	0.80
4. Cold Side Frame Emittance	0.80
5. Warm Side Sash/Panel/Vent Emittance	N/A
6. Cold Side Sash/Panel/Vent Emittance	N/A
7. Warm Side Baffle Emittance (e_{b1})	0.92
8. Equivalent Warm Side Surface Temperature	48.29 F
9. Equivalent Cold Side Surface Temperature	5.27 F
10. Warm Side Baffle Surface Temperature	69.29 F
11. Measured Warm Side Surface Conductance (h_h)	1.44 Btu/hr·ft ² ·F
12. Measured Cold Side Surface Conductance (h_c)	5.45 Btu/hr·ft ² ·F
13. Test Specimen Thermal Conductance (C_s)	0.72 Btu/hr·ft ² ·F
14. Convection Coefficient (K_c)	0.33 Btu/(hr·ft ² ·F ^{1.25})
15. Radiative Test Specimen Heat Flow (Q_{r1})	680.30 Btu/hr
16. Conductive Test Specimen Heat Flow (Q_{c1})	661.04 Btu/hr
17. Radiative Heat Flux of Test Specimen (q_{r1})	15.70 Btu/hr·ft ² ·F
18. Convective Heat Flux of Test Specimen (q_{c1})	15.25 Btu/hr·ft ² ·F
19. Standardized Warm Side Surface Conductance (h_{sth})	1.21 Btu/hr·ft ² ·F
20. Standardized Cold Side Surface Conductance (h_{stc})	5.28 Btu/hr·ft ² ·F
21. Standardized Thermal Transmittance (U_{st})	0.42 Btu/hr·ft ² ·F

Test Duration

1. The environmental systems were started at 12:00 hours, 09/11/12.
2. The test parameters were considered stable for two consecutive four hour test periods from 23:36 hours, 09/11/12 to 07:36 hours, 09/12/12.
3. The thermal performance test results were derived from 03:36 hours, 09/12/12 to 07:36 hours, 09/12/12.

The reported Standardized Thermal Transmittance (U_{st}) was determined using CTS Method, per Section 8.2(A) of NFRC 102.

Glazing Deflection (in):

	Left Glazing	Right Glazing
Edge Gap Width	0.50	0.50
Estimated center gap width upon receipt of specimen in laboratory (after stabilization)	0.34	0.32
Center gap width at laboratory ambient conditions on day of testing	0.34	0.32
Center gap width at test conditions	0.27	0.27

Glass collapse determined using a digital glass and air space meter

The sample was inspected for the formation of frost or condensation, which may influence the surface temperature measurements. The sample showed no evidence of condensation/frost at the conclusion of the test.

A calibration of the Architectural Testing Inc. 'thermal test chamber' (ICN N000235) in St. Paul, Minnesota was conducted in October 2011 in accordance with Architectural Testing Inc. calibration procedure.

"This test method does not include procedures to determine the heat flow due to either air movement through the specimen or solar radiation effects. As a consequence, the thermal transmittance results obtained do not reflect performances which may be expected from field installations due to not accounting for solar radiation, air leakage effects, and the thermal bridge effects that may occur due to the specific design and construction of the fenestration system opening. Therefore, it should be recognized that the thermal transmittance results obtained from this test method are for ideal laboratory conditions and should only be used for fenestration product comparisons and as input to thermal performance analyses which also include solar, air leakage and thermal bridge effects."

"Ratings included in this report are for submittal to an NFRC-licensed IA for certification purposes and are not meant to be used for labeling purposes. Only those values identified on a valid Certification Authorization Report (CAR) are to be used for labeling purposes."

The test sample was installed in a vertical orientation, the exterior of the specimen was exposed to the cold side. The direction of heat transfer was from the interior (warm side) to the exterior (cold side) of the specimen.

ANSI/NCSL Z540-2-1997 type B uncertainty for this test was 1.62%.

Detailed drawings, data sheets, representative samples of test specimens, a copy of this report, or other pertinent project documentation will be retained by Architectural Testing, Inc. for a period of four years from the original test date. At the end of this retention period such materials shall be discarded without notice and the service life of this report by Architectural Testing will expire. Results obtained are tested values and were secured by using the designated test methods. This report does not constitute certification of this product nor an opinion or endorsement by this laboratory. Ratings included in this report are for submittal to an NFRC licensed IA for certification purposes and are not meant to be used for labeling purposes. Only those values identified on a valid Certification Authorization Report (CAR) are to be used for labeling purposes. It is the exclusive property of the client so named herein and relates only to the specimen(s) tested. This report may not be reproduced, except in full, without the written approval of Architectural Testing, Inc.

For ARCHITECTURAL TESTING, INC.

Tested By:

Reviewed By:

Michael P. Resech
Senior Project Manager
Individual-In-Responsible-Charge

Daniel A. Johnson
Director – Regional Operations
Individual-In-Responsible-Charge

MDT:mpr
C2485.01-201-46

Attachments (pages): This report is complete only when all attachments listed are included.

- Appendix-A: Description Table Abbreviations (1)
- Appendix-B: CTS Calibration Data (1)
- Appendix-C: Surround Panel Wiring Diagram (1)
- Appendix-D: Baffle Wiring Diagram (1)
- Appendix-E: Submittal Form and Drawings (11)

Revision Log

<u>Rev. #</u>	<u>Date</u>	<u>Page(s)</u>	<u>Revision(s)</u>
01-R0	11/29/12	All	Original Report Issue. Work requested by Don Willard of US Aluminum Inc., Division of CR Laurence Co., Inc.

Appendix A: Description Table Abbreviations

CODE	Frame / Sash Types
AI	Aluminum w/ Vinyl Inserts (Caps)
AL	Aluminum
AP	Aluminum w/ Thermal Breaks - Partial
AS	Aluminum w/ Steel Reinforcement
AT	Aluminum w/ Thermal Breaks - All Members ($\geq 0.21"$)
AU	Aluminum Thermally Improved - All Members (0.062" - 0.209")
AV	Aluminum / Vinyl Composite
AW	Aluminum-clad Wood
FG	Fiberglass
PA	ABS Plastic w/ All Members Reinforced
PC	ABS Plastic-clad Aluminum
PF	ABS Plastic w/ Foam-filled Insulation
PH	ABS Plastic w/ Horizontal Members Reinforced
PI	ABS Plastic w/ Reinforcement - Interlock
PL	ABS Plastic
PP	ABS Plastic w/ Reinforcement - Partial
PV	ABS Plastic w/ Vertical Members Reinforced
PW	ABS Plastic-clad Wood
ST	Steel
VA	Vinyl w/ All Members Reinforced
VC	Vinyl-clad Aluminum
VF	Vinyl w/ Foam-filled Insulation
VH	Vinyl w/ Horizontal Members Reinforced
VI	Vinyl w/ Reinforcement - Interlock
VP	Vinyl w/ Reinforcement - Partial
VV	Vinyl w/ Vertical Members Reinforced
VW	Vinyl-clad Wood
VY	Vinyl
WA	Aluminum / Wood composite
WD	Wood
WV	Vinyl / Wood composite
WF	Fiberglass/Wood Combination
WC	Composite/Wood Composite (Shaped vinyl/wood composite members)
CW	Copper Clad Wood
CO	Vinyl/Wood Composite Material

DOOR DETAILS	
N	Not Applicable
CODE	Door Type
EM	Embossed
FL	Flush
LF	Full Lite
LH	1/2 - Lite
LQ	1/4 - Lite
LT	3/4 - Lite
RP	Raised Panel
CODE	Skin
AL	Aluminum
FG	Fiberglass
GS	Galvanized Steel
ST	Steel
WD	Wood
VY	Vinyl
CODE	Panel
FG	Fiberglass
PL	Plastic
WP	Wood - Plywood
WS	Wood - Solid
CODE	Sub-Structure
GS	Galvanized Steel
ST	Steel
WD	Wood
VY	Vinyl
CODE	Core Fill
CH	Cellular - Honeycomb
EP	Expanded Polystyrene
PI	Polyisocyanurate
PU	Polyurethane
WP	Wood - Plywood
WS	Wood - Solid
XP	Extruded Polystyrene

CODE	Spacer Types (See sealant)
A1	Aluminum
A2	Aluminum (Thermally-broken)
A3	Aluminum-reinforced Polymer
A4	Aluminum / Wood
A5	Aluminum-reinforced Butyl (Swiggle)
A6	Aluminum / Foam / Aluminum
A7	Aluminum U-shaped
A8	Aluminum-Butyl (Corrugated) (Duraseal)
ER	EPDM Reinforced Butyl
FG	Fiberglass
GL	Glass
OF	Organic Foam
P1	Duralite
PU	Polyurethane Foam
SU	Stainless Steel, U-shaped
CU	Coated Steel, U-shaped (Intercept)
S2	Steel (Thermally-broken)
S3	Steel / Foam / Steel
S5	Steel-reinforced Butyl
S6	Steel U-channel w/ Thermal Cap
SS	Stainless Steel
CS	Coated Steel
TP	Thermo-plastic
WD	Wood
ZE	Elastomeric Silicone Foam
ZF	Silicone Foam
ZS	Silicone / Steel
N	Not Applicable
TS	Thermo-plastic w/ stainless steel substrate

CODE	Tint Codes
AZ	Azurlite
BL	Blue
BZ	Bronze
CL	Clear
EV	Evergreen
GD	Gold
GR	Green
GY	Gray
LE	Low 'e' Coating
OT	Other (use comment field)
RC	Solar or Reflective Coating
RG	Roller Shades between glazing
RS	Silver (reflective coating)
SF	Suspended Polyester Film
SR	Silver
BG	Blinds between the Glazing
DV	Dynamic Glazing-Variable
DY	Dynamic Glazing-NonVariable

CODE	Gap Fill Codes
AIR	Air
AR2	Argon/Krypton Mixture
AR3	Argon / Krypton / Air
ARG	Argon/Air
CO2	Carbon Dioxide
KRY	Krypton/Air
SF6	Sulfur Hexafluoride
XE2	Xenon/Krypton/Air
XE3	Xenon/Argon/Air
XEN	Xenon/Air
N	Not Applicable

CODE	Spacer Sealant
D	Dual Seal Spacer System
S	Single Seal Spacer System

CODE	Grid Description
N	No Muntins
G	Grids between glass
S	Simulated Divided Lites
T	True Muntins

CODE	Grid Size Codes
	Blank for no grids
0.75	Grids $< 1"$
1.5	Grids $\geq 1"$

CODE	Thermal Breaks
F	Foam
U	Urethane
V	Vinyl
FB	Fiberglass
O	Other
AB	ABS
NE	Neoprene
AI	Air
N	Not Applicable
P	Polyamide

Appendix B: CTS Calibration Data

1. CTS Test Date	10/22/11
2. CTS Size	43.05 ft ²
3. CTS Glass/Core Conductance	0.41 Btu/hr·ft ² ·F
4. Warm Side Air Temperature	70.06 F
5. Cold Side Air Temperature	0.25 F
6. Warm Side Average Surface Temperature	55.19 F
7. Cold Side Average Surface Temperature	4.08 F
8. Convection Coefficient (K _c)	0.33 Btu/(hr·ft ² ·F ^{1.25})
9. Measured Cold Side Surface Conductance (h _c)	5.45 Btu/hr·ft ² ·F
10. Measured Thermal Transmittance	0.29 Btu/hr·ft ² ·F

Appendix C: Surround Panel Wiring Diagram

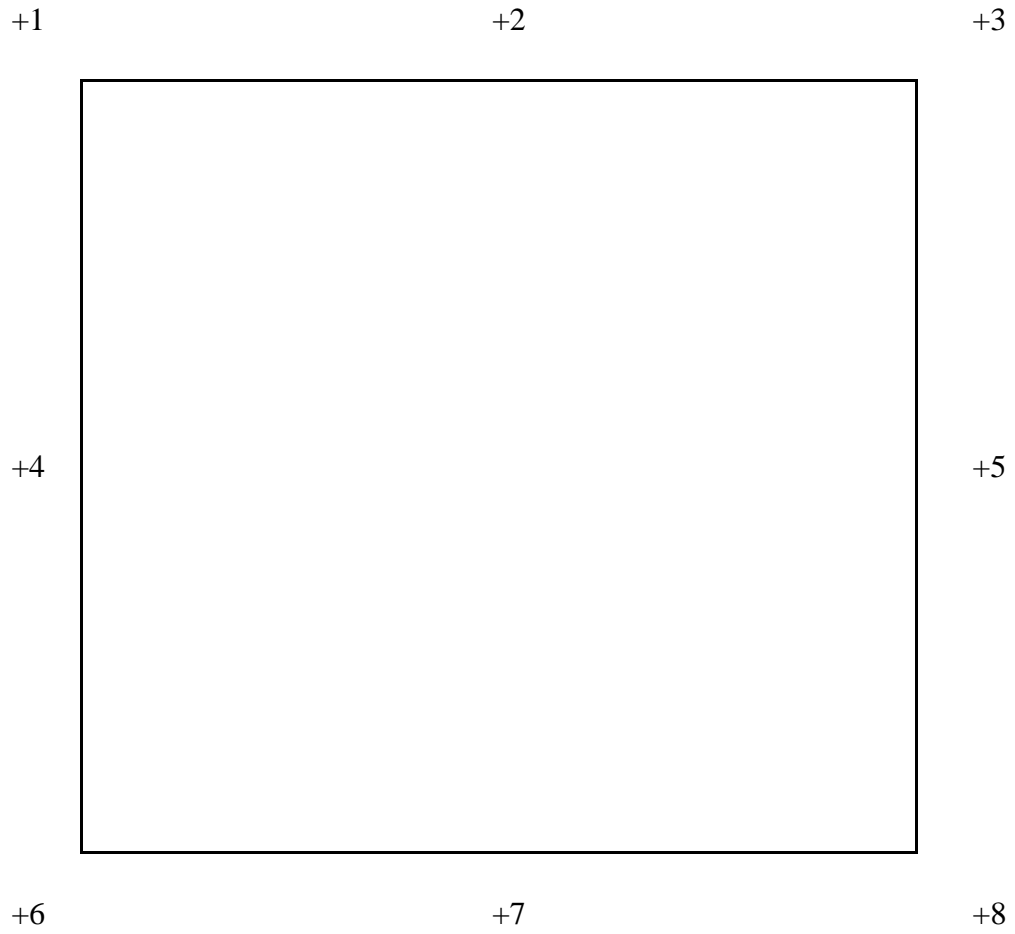

Appendix D: Baffle Wiring Diagram

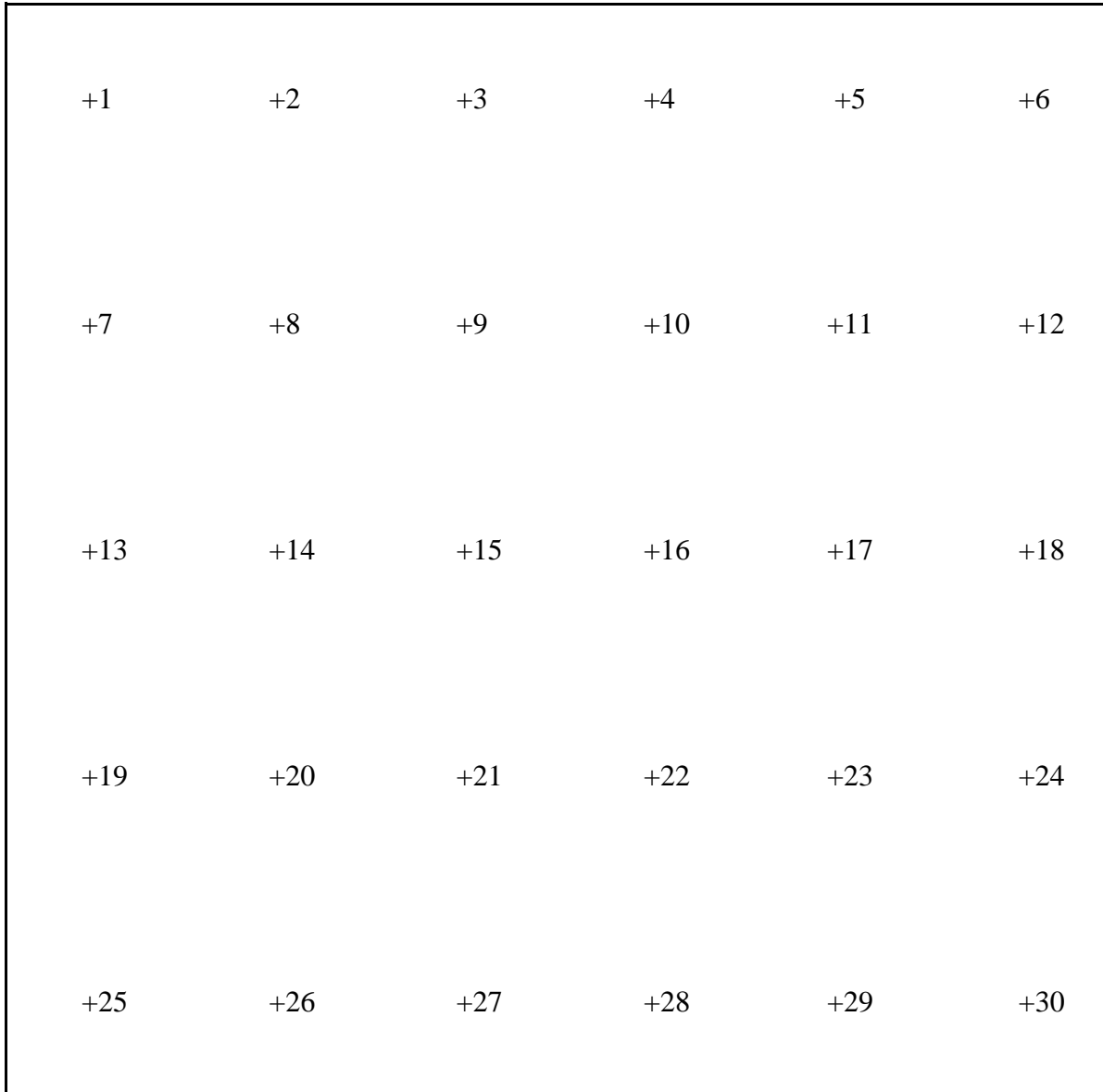

Appendix E: Submittal Form and Drawings

NFRC PRODUCT CERTIFICATION PROGRAM

Submittal Form for Test Samples

For use by manufacturers, lineal suppliers and fabricators



National Fenestration
Rating Council®

1. Information on Production of the Test Sample (complete ALL fields):

Manufacturer: US Aluminum Date of sample manufacture: 08-2012

Plant Address where manufactured: Waxahachie

City: Waxahachie State: Texas Zip Code: 75165

Name of IA: ALI Phone: 214.565.0593 Fax: 214.565.1094

2. Product Information (complete ALL fields):

Product Line ID (CPD) No.: New Product/Operator Type (Table 4-3 of NFRC 100): NA

Series/Model : FT451 Inside set

3. Test sample is being submitted for (select ONE):

- a. Validation for Initial Certification (prototype only) no plant qualification
- b. Validation for Initial Certification (production line unit) & plant qualification
- c. Validation for Recertification (production line unit) & plant qualification
- d. Plant Qualification Only (production line unit)

I, Don Willard, as the designated agent for US Aluminum

do hereby attest that the foregoing information is true to the best of my information, knowledge, and belief. Further, if the unit is identified in Section 3 as a production line unit, I hereby authorize the NFRC-accredited testing laboratory to send a copy of the test report to the IA identified above for plant qualification purposes pursuant to the NFRC Product Certification Program..

Signature: Don Willard Date: 12.04.12

FOR LABORATORY USE ONLY

- 1. Laboratory: ARCHITECTURAL TESTING, INC.
- 2. Date Sample Received: 8/30/12 File number ID: 62485
- 3. Date Sample Tested: 9/12/12 By: [Signature]
- 4. Modifications made: -

5. Reason for non-testing of sample unit: _____

[Note: If the sample submitted can not be tested due to damage prior to testing, a new sample and new form shall be submitted to the testing laboratory. Both forms shall be submitted to the IA when the testing is completed.]

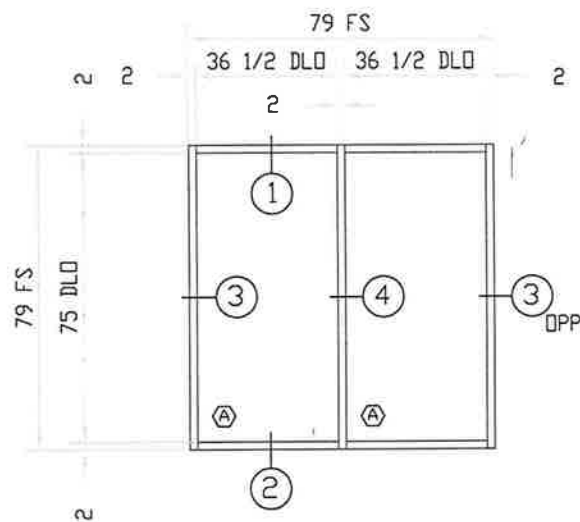

Architectural Testing

Test sample complies with these details.
Deviations are noted.

Report# C2485
Date 11/8/12 Tech MB

(A)
QTY = 1

SYMBOL KEY

SYMBOL	DESCRIPTION	QTY	COMMENTS
(A)	37.375 X 75.875	2	1 INS = INSULATED GLASS

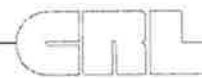

DIVISION

REV	REV_DESCRIPTION	DATE	XXX	DCW	THERMAL_TEST_NFRC_AAMA_1503	DWG NO
				08.17.12		
				3/8'=1'	SERIES_FT451-INSIDE_SET	MU2012-013-01

1

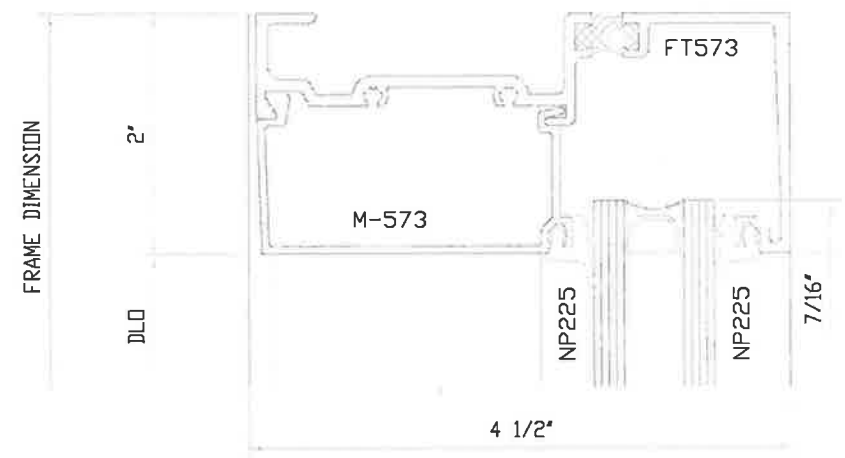

2

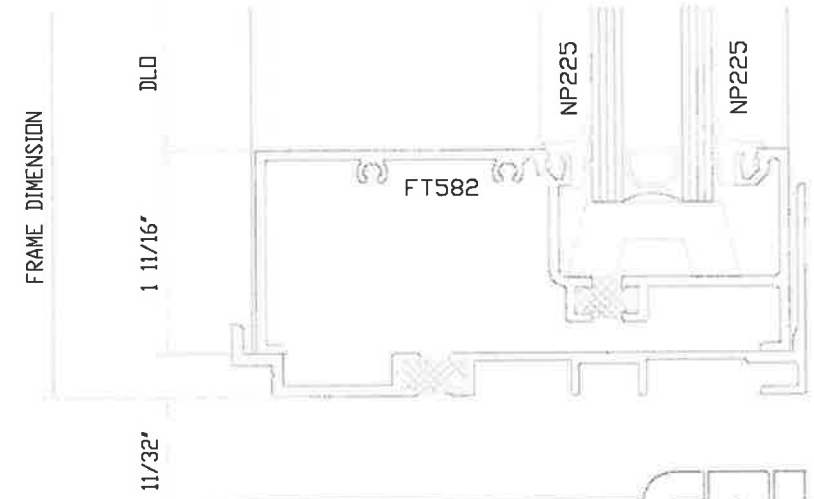

Test sample complies with these details.
Deviations are noted.

Report# C2485
Date 11/8/12 Tech YB

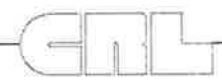

REV	REV_DESCRIPTION	DATE	XXX	NO. OF	DCW	THERMAL_TEST_NFRC_AAMA_1503	LWD NO
					08.17.12	SERIES_FT451-INSIDE_SET	MU2012-013-02
SYM	REVISION	DATE	BY		FULL		

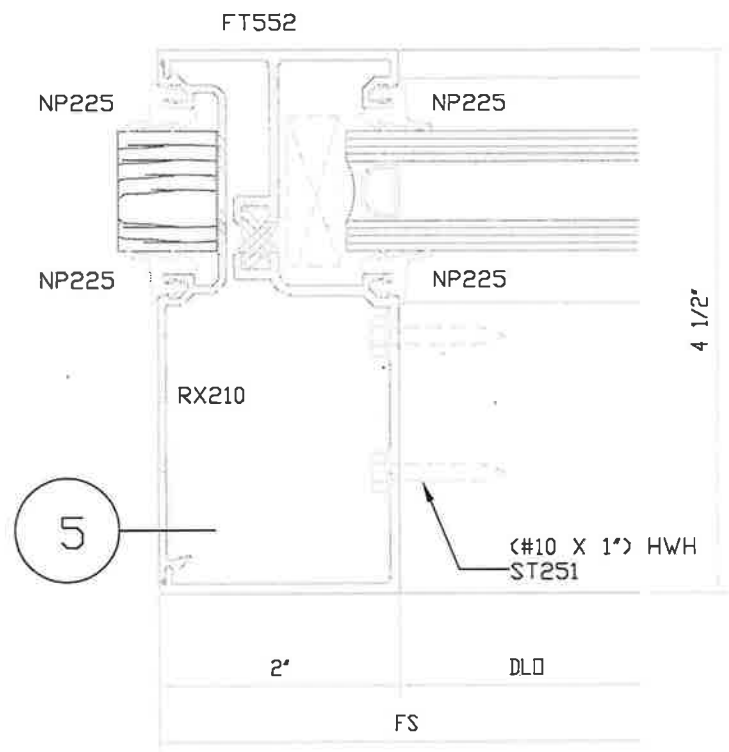

3

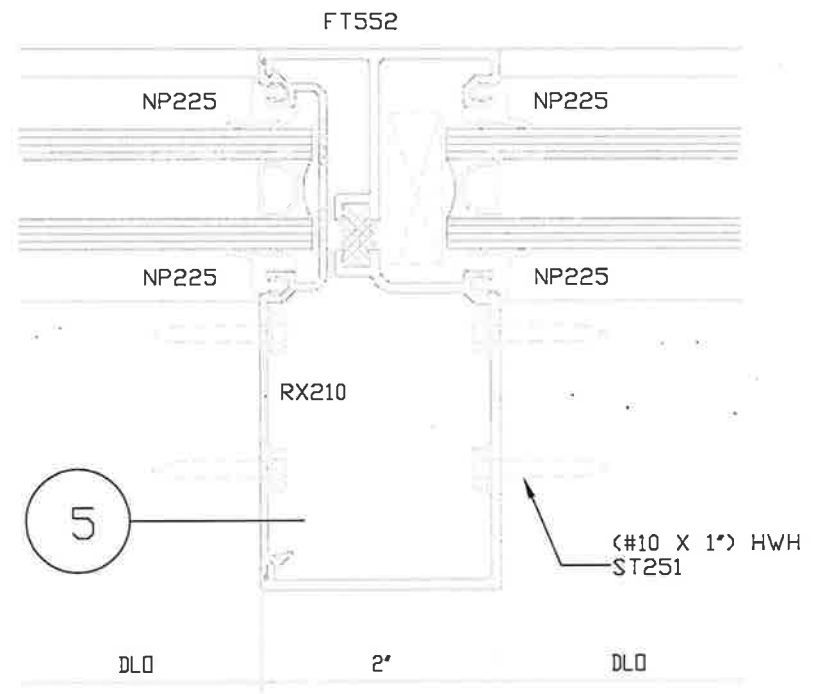

4

Architectural Testing

Test sample complies with these details.
 Details are noted.

Report# C-2485
 Date 11/8/12 Tech HB

				CNL			
				DIVISION			
				DCW		THERMAL_TEST_NFRC_AAMA_1503	
				08.17.12		LWD RD	
				FULL		SERIES_FT451-INSIDE_SET	
						MU2012-013-03	
REV	REV_DESCRIPTION	DATE	XXX				
SYM	REVISION	DATE	BY				

Test sample complies with these details.
Deviations are noted.

Report# C2485 B 8199
Date 11/8/12 Tech WJA

B	.040 WAS RECALC'D	RT GH	10/30 97	U.S. ALUMINUM CORP.		T-31788 B
				HEAD - 1"	MAMO	8/3/93
				FF573	FULL SIZE	

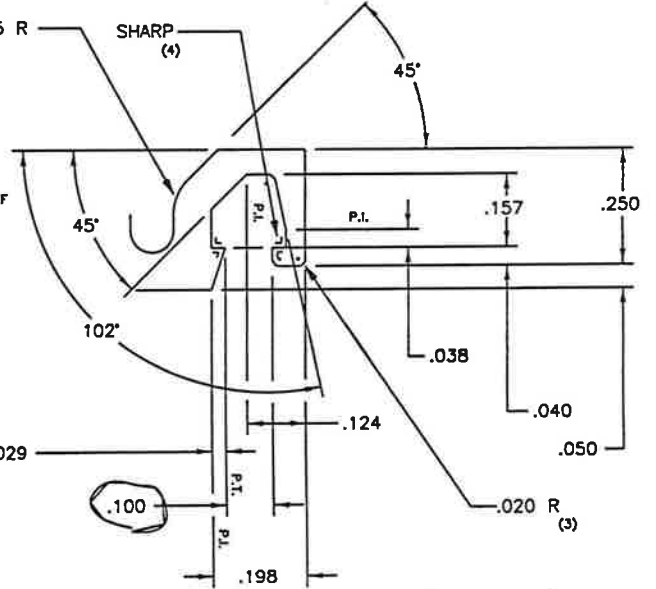
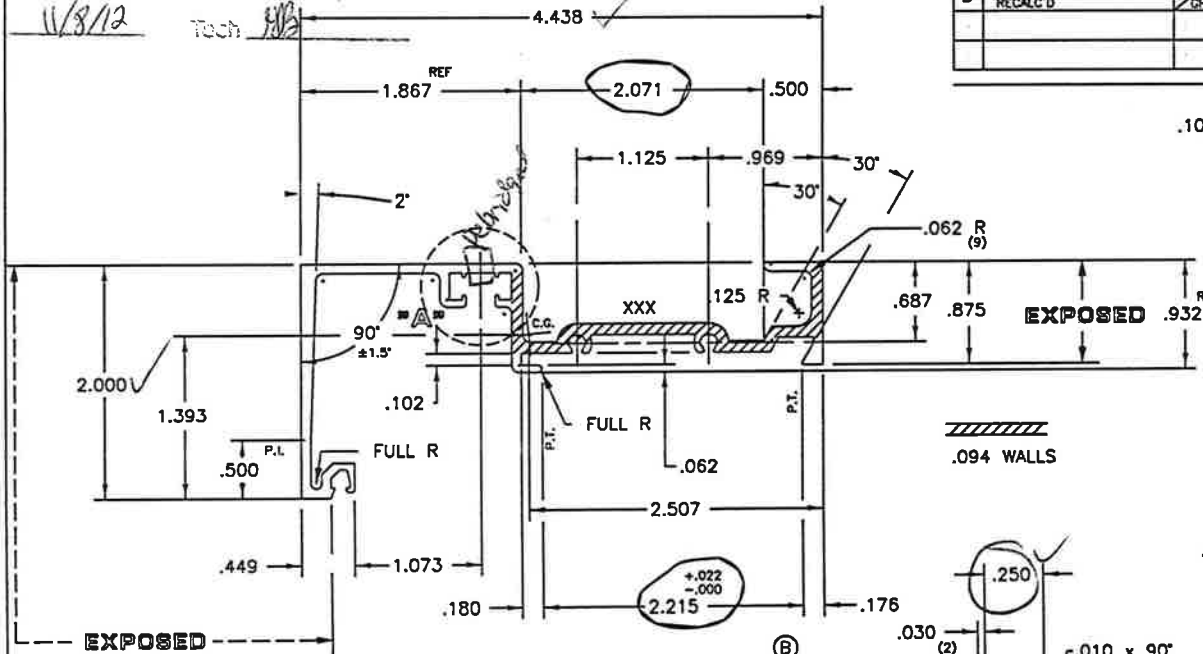

GASKET POCKET DETAIL
SCALE: 4X SIZE

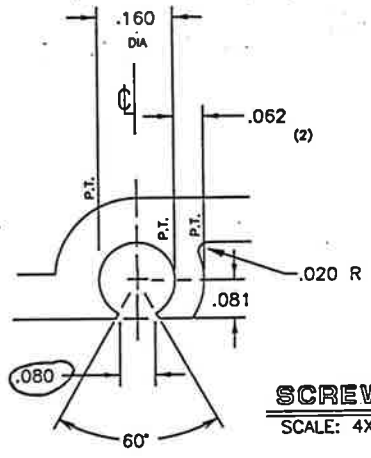

SCREW RACE DETAIL
SCALE: 4X SIZE (2 PLACES)

- NOTES:**
1. SNAP-FITS W/M-573; DIE #31365
ASSEMBLES W/HC201; DIE #31347
 2. PAINT PERIMETER: 3.188"
 3. THERMO DETAIL AREA: .132; "AA"
 4. DEBRIDGE WITH A .218 x .015 MAX PENETRATION INTO THERMO MATERIAL.
 5. XXX INDICATES I.D. MARK FOR IEC-TX
 6. F & D PART NO. IS FT573

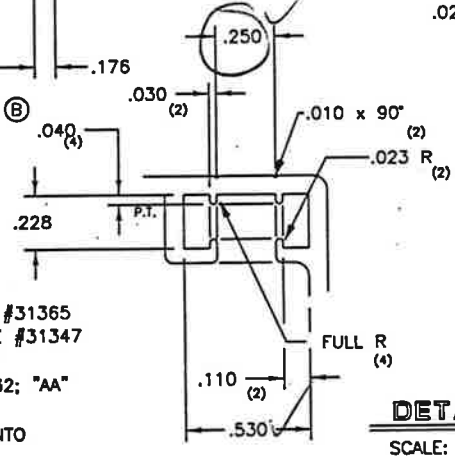

SECTION PROPERTIES:

I_{xx} = 2.259 in⁴
S_{xx} = 0.901 in³
I_{yy} = 0.242 in⁴
S_{yy} = 0.174 in³

10x1 1/2 W/P 10x1 1/4 DIE NO STEP

	.080		
	.930 (B)	1 / W/P 31788	
	1.116 (B)	5.000	10x31359
	21.321 (B)	SOLID	12x7 1/2 31359
	19	8" = 61	T-31788 B

EXPOSED

SYN	REVISION	BY	DATE	CUSTOMER	U.S. ALUMINUM CORP.	DIE NO.	31508
				INSERT	MAMO	DATE	11/18/94
				PART NAME	RE210	SCALE	FULL SIZE
				PART NO.		DATE	

Architectural Testing

Test sample complies with these details.
Deviations are noted.

Report# C2485 B 8199

Date 11/8/12 Tech HB

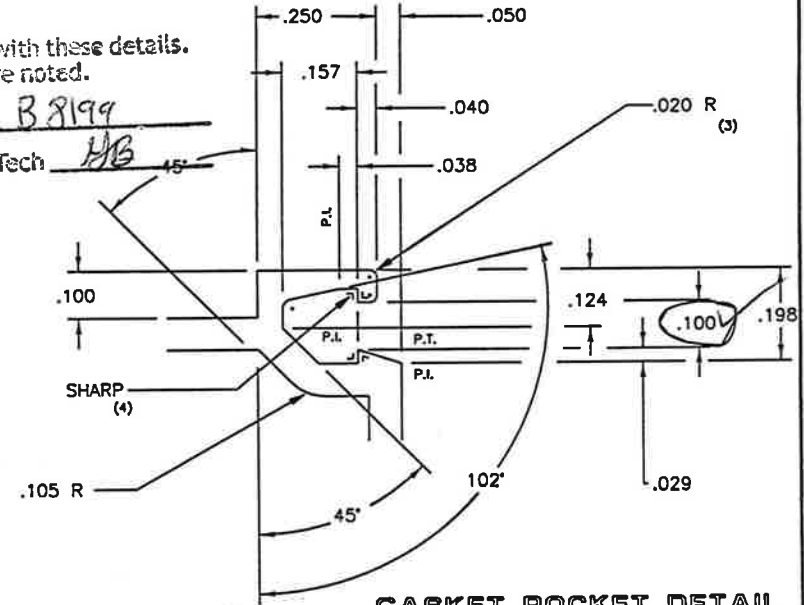
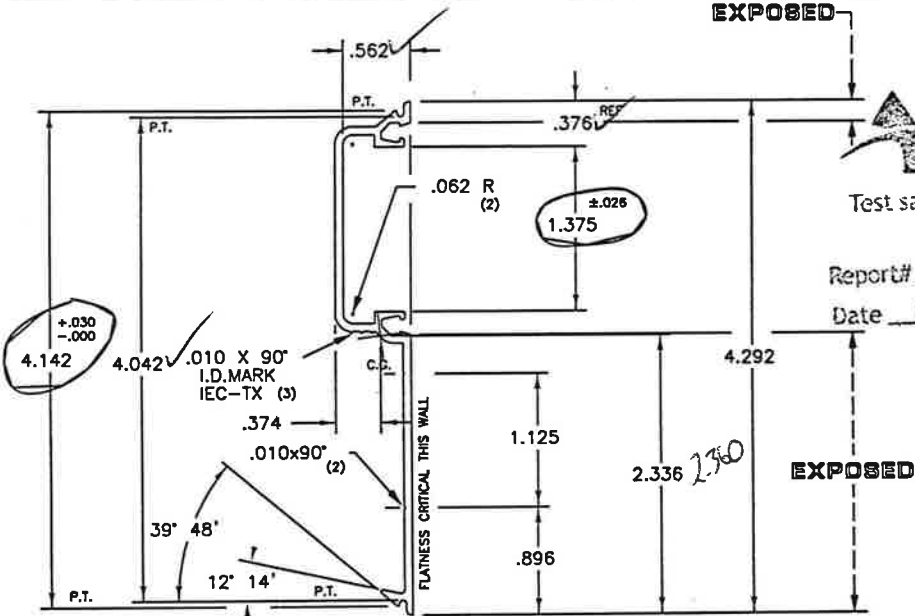

GASKET POCKET DETAIL

SCALE: 4X SIZE (2 PLACES)

NOTES:

1. SNAP-FITS W/FF552; DIE # 31507
W/FF551; DIE # 31512

2. PAINT PERIMETER: 2.522"

SECTION PROPERTIES:

lxx = 0.643 in 4
Sxx = 0.275 in 3
lyy = 0.023 in 4
Syy = 0.061 in 3

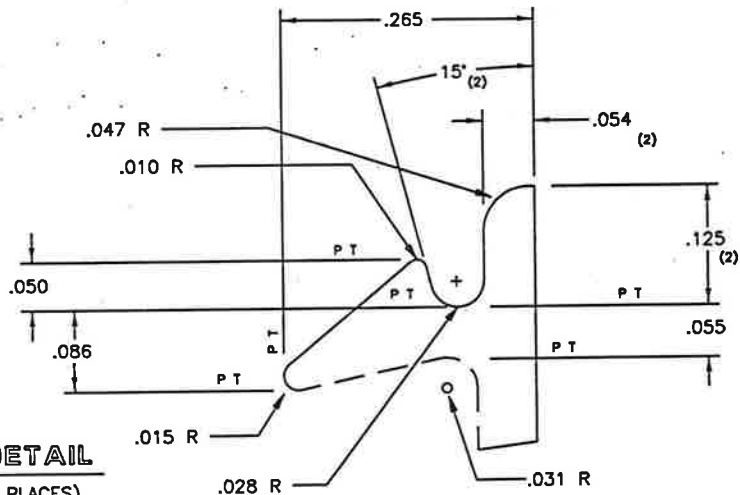

SNAP DETAIL

SCALE: 8X (2 PLACES)

PRODUCT:
PROJECT:

CA
 TX

International Extrusion Corporation
202 SINGLETON DRIVE WAXAHACHE TEXAS 75165
(972) 937-7032

UNLESS OTHERWISE NOTED, ALL CORNERS ARE .015 R, AND TYPICAL WALL THICKNESS IS .068

EST. AREA:	.397	US-NO.	P-24052	PORTS
EST. WT/FT:	.476	CIRCLE SIZE	4.292 ^{IN}	BACKER
EST. PER:	12.268	CLASS.	SOLID	BOLSTER.
FACTOR :	26	ER-		DIE NO. T-31508

B	.040 WAS .023, RECALC'D	RT	07/30	U.S. ALUMINUM CORP.		T-31507	B
		CH	97	VERT MULL	MAMO	11/18/94	
				FF552	FULL SIZE		

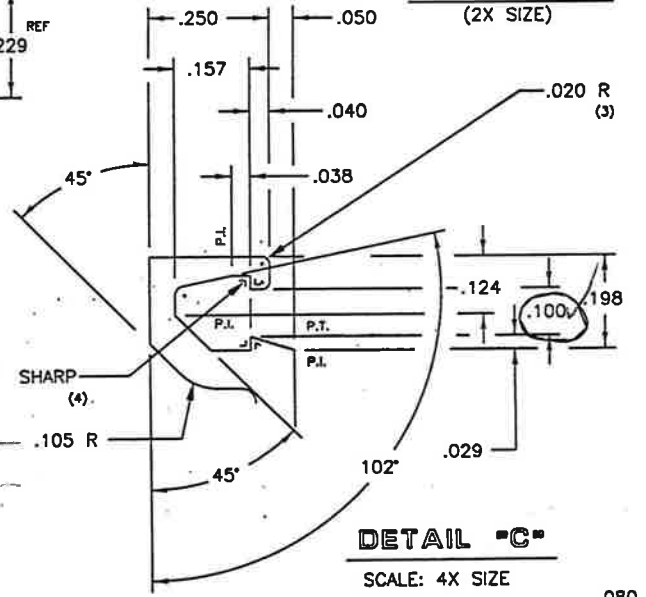
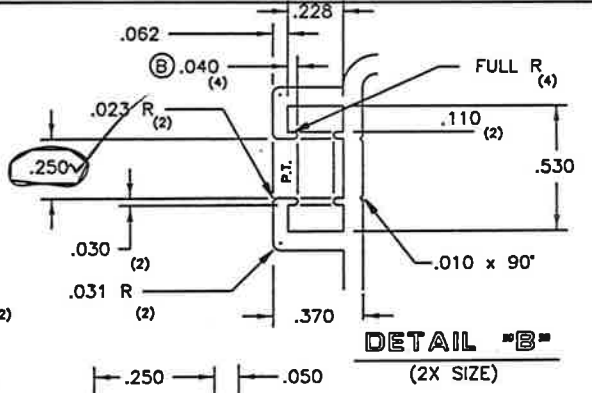
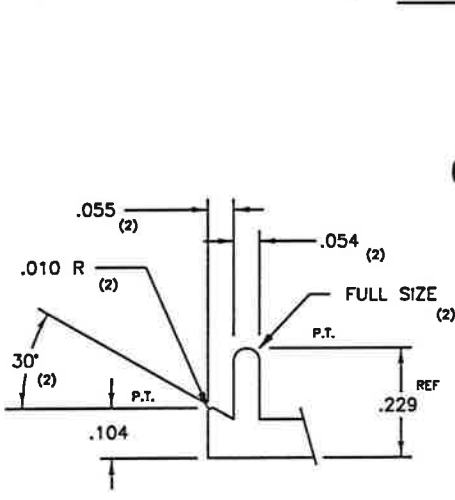
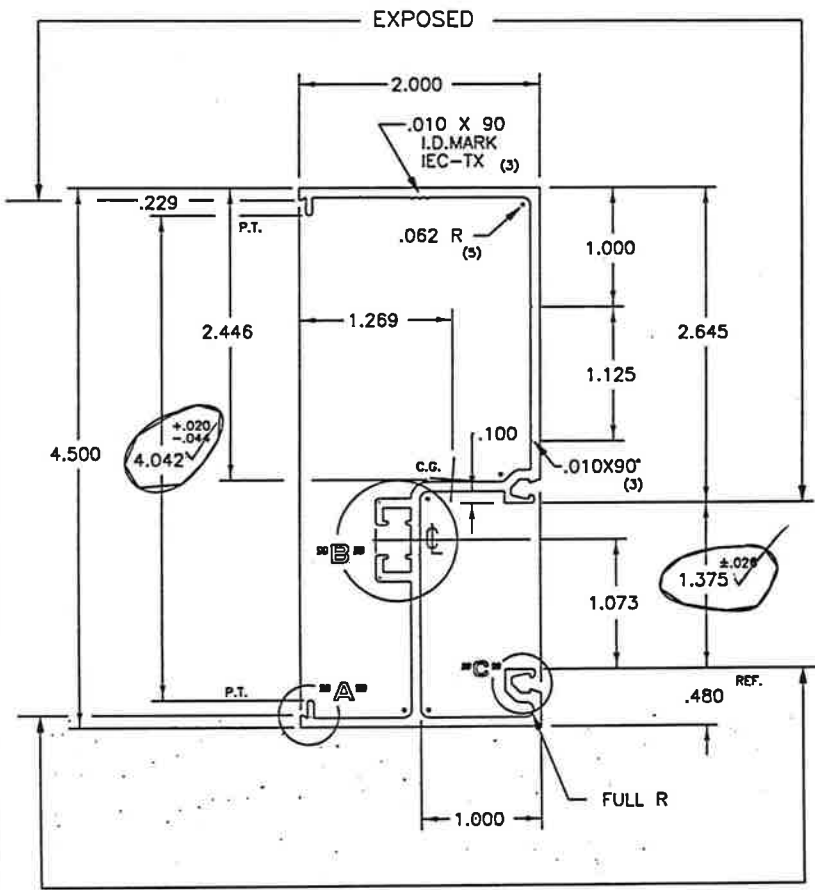

NOTES:

1. SNAP-FITS W/RF210; DIE #31508
W/RF110; DIE #31509
W/PF100; DIE #31510
2. PAINT PERIMETER: 6.758"
3. THERMO POCKET AREA: .132; "AA"
4. F & D PART NO. IS FT552

SECTION PROPERTIES:

$I_{xx} = 2.408 \text{ in}^4$
 $S_{xx} = 0.984 \text{ in}^3$
 $I_{yy} = 0.311 \text{ in}^4$
 $S_{yy} = 0.245 \text{ in}^3$

Architectural Testing
 Report # C2485 B8199
 Date 11/8/12 Tech YJB

	.897 (B)	P-24046	1	WP31507
	1.076 (B)	4.915	10	X 31507
	23.378 (B)	SOLID		31355
	22	8 60		T-31507 B

FF451

B		SCREWRACE DETAIL REVISED	MM	10/27/93	U.S. ALUMINUM CORP.		T-31362	C
C		.040 WAS RECALC'D	RT/DH	10/28/97	SILL - INSIDE GLAZE	MAMO	6/21/93	
					FF582	FULL SIZE		

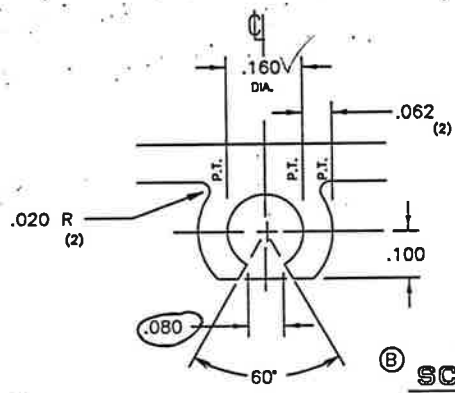
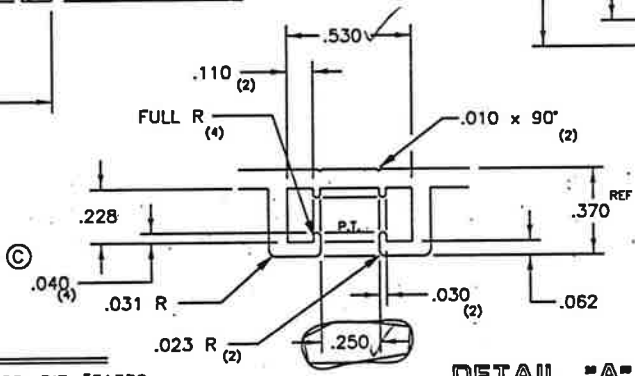
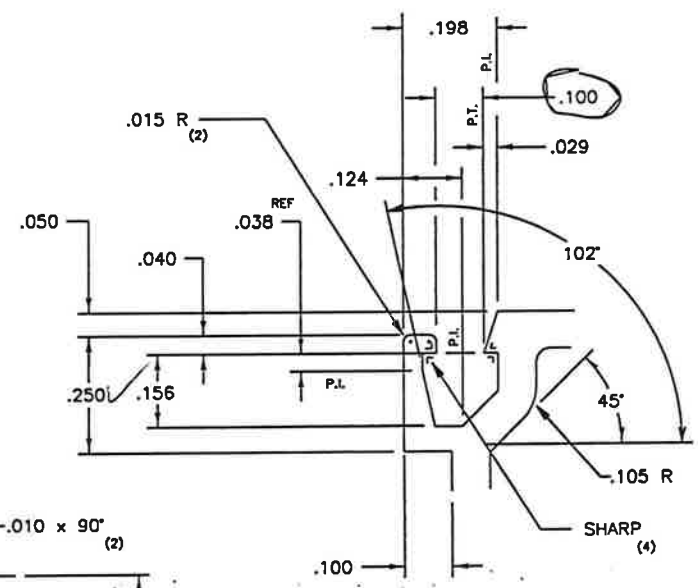
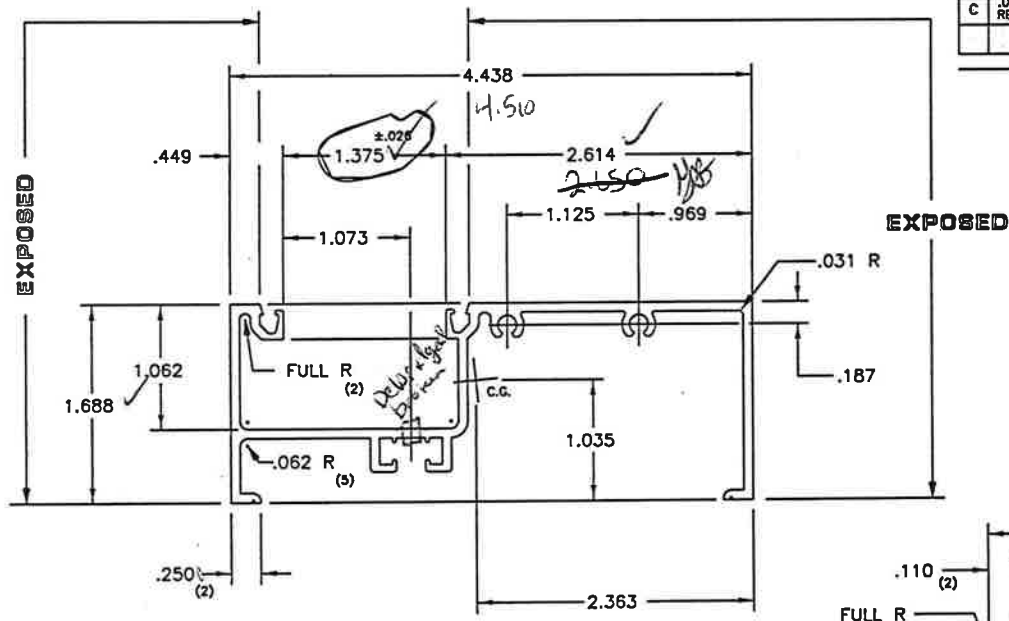

- NOTES:**
- MATES W/FF400, DIE #31332
 - PAINT PERIMETER: 6.043"
 - THERMO DETAIL AREA: .132; "AA"
 - DEBRIDGE WITH A .218 x .015 MAX PENETRATION INTO THERMO MATERIAL.
 - F & D PART NO. IS FT582

SECTION PROPERTIES:

Ixx = 2.195 in⁴

Sxx = 0.929 in³

Iyy = 0.270 in⁴

Syy = 0.261 in³

10x1 1/2 W/P 10x1 1/4 DIE NO STEP

CA			.080
TX			
	.918 (C)	P-21774	1 / W/P 31362
	1.102 (C)	4.800	10x31362
	23.515 (C)	SOLID	12x7 1/2 31362
	21	8" = 59	T-31362 C

Architectural Testing

Test sample complies with these details.
Deviations are noted.

Report# C2485 B8199

Date 11/8/12 Tech HB

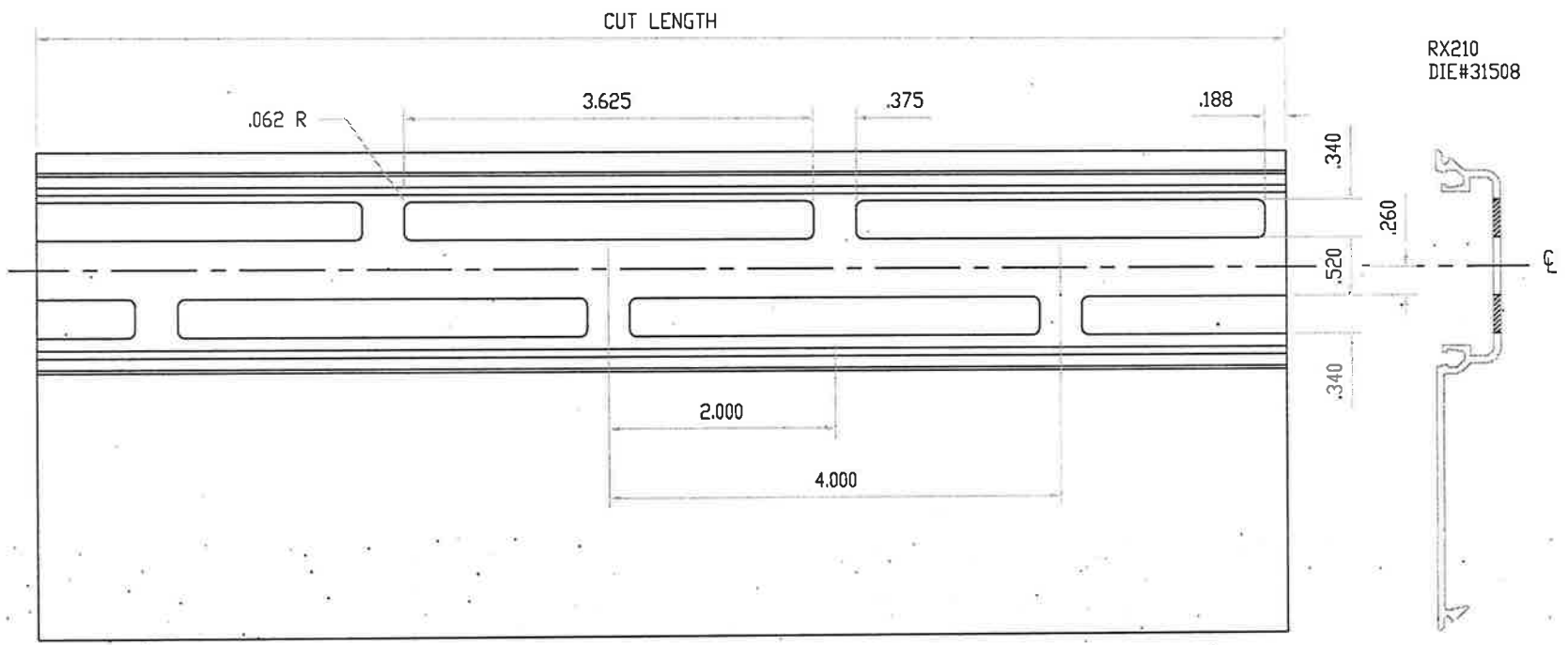

5

TYPICAL FILLER THERMAL SLOTS



Architectural Testing

Test sample complies with these details.
Deviations are noted.

Report# C2485 B8199
Date: 11/8/12 Tech MB

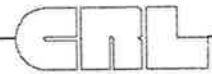

REV	REV_DESCRIPTION	DATE	XXX	DIVISION	THERMAL_TEST_NFRC_AAMA_1503	DWG NO
SYN	REVISION	DATE	BY	DCW	SERIES_FT451-INSIDE_SET	MU2012-013-04
				08.17.12		
				FULL		



Architectural Testing

Test sample complies with these details.
Deviations are noted.

Report# B8199 C2485
Date 11/8/12 Tech HB

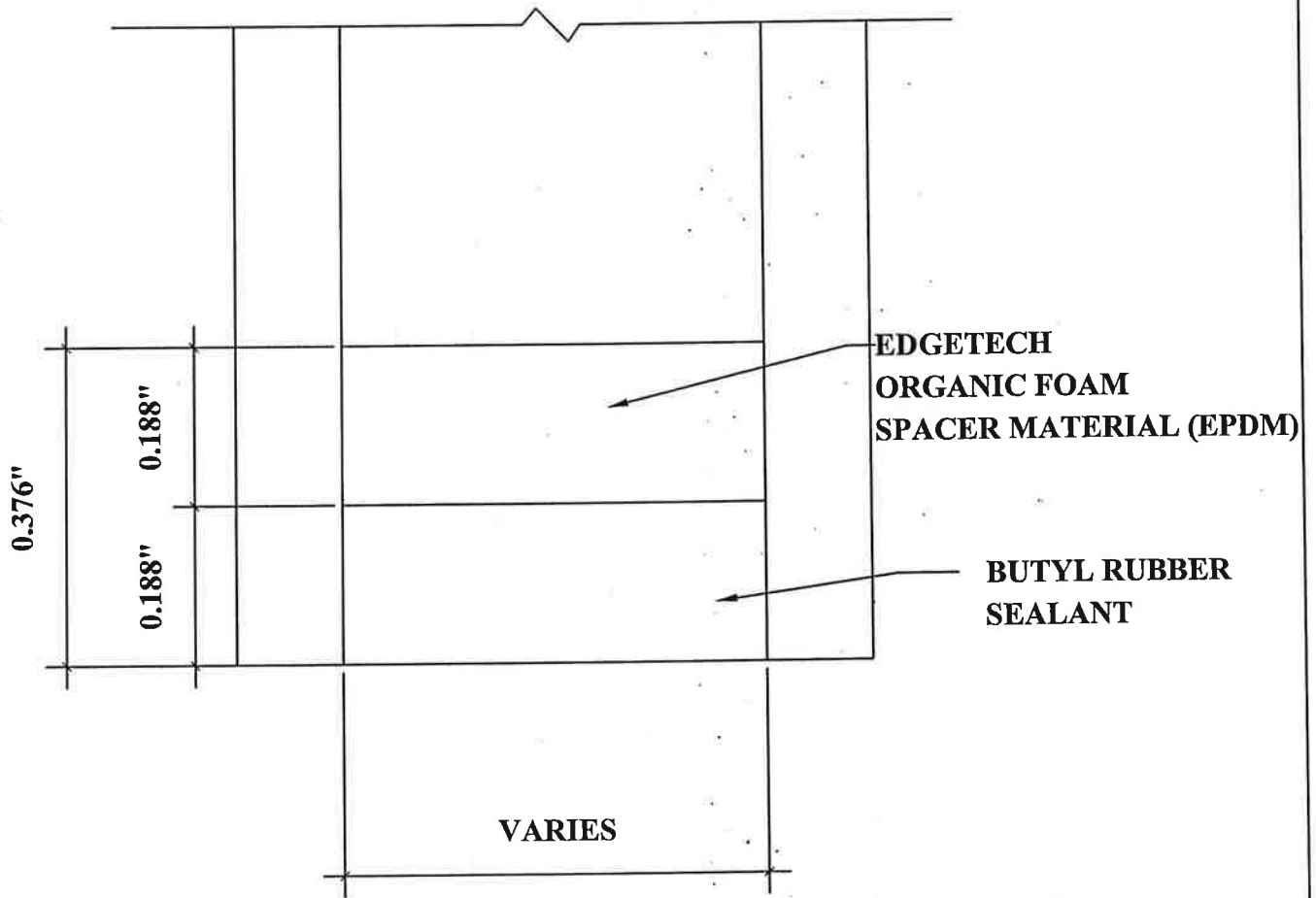

DETAIL FOR THERMAL MODELING OF
EDGETECH SUPER SPACER STANDARD (OF-S)