

The following instructions cover the 300 series strike models.

INSTALLATION

- For proper installation of the 300 strike refer to the appropriate template drawing. The centerline of the latch bolt must be aligned with the centerline of the strike.
- Prior to installation make the necessary wire connections per the appropriate wiring diagram.
- Proper operating voltage must be supplied to the strike if it is to function correctly. Voltage at the strike must be within ± 10% of the required voltage listed on the strike label.
- To install the strike into the frame opening:
 - Position the wiring either down or up or toward the back of the hollow metal frame, making sure that it stays completely out of the way of the strike so as not to pinch it when installing.

B) Mount the strike using the screws supplied:

Strike Model	Mounting Screws
310-2, 2RF, 2-3/4, 2-3/4OB, 2-3/4U, 3-1, 3-1DBS	(2) 12-24 x 1/2 FHPMS (4) 14 x 1-1/2 FHPWS
310-2W	(4) 14 x 1-1/2 FHPWS
310-4, 4-1, 4-2, 4-3, 4-30, 4DBR	(2) 1/4-20 x 1 FILHMS
310-4-100	(4) 1/4-20 x 5/8 BHCS
310-4W	(4) 14 x 2 RHPWS
310-5	(2) 12-24 x 3/4 FILHMS
310-6-8, 6-1, 6-2, 6-3, 6-30	(5) 12-24 x 1/2 FHPMS

- After installation check the horizontal alignment, be certain that the centerline of the latch bolt is aligned with the centerline of the strike.
- In case of misalignment there is a 3/16" horizontal adjustment between the strike mechanism and the face plate. To adjust:
 - Remove mounting screws.
 - Remove strike from frame.
 - Loosen the two (2) 12-24 x 3/8 Hex Washer Head Cap screws.
 - Reposition strike and re-tighten cap screws.
 - Reinstall strike in frame.
 - Reinstall mounting screws.

OPERATION

The Folger Adam 300 electric strike is a solenoid operated device.

- NON-FAIL-SAFE**
When power is applied the solenoid pulls the locking cam into the unlocked position allowing the door to be opened. If power fails the strike will remain locked.

NOTE: Non-fail-safe strikes for use in fire rated doors can only be operated by momentary contact switching (energized only when the push button is held depressed) and cannot be held in the unlocked position.
- FAIL-SAFE**
When power is applied the solenoid pushes the locking cam into the locked position and the door cannot be opened. If power fails the strike will unlock.

OPERATIONAL NOTE

This product may be provided fail safe or fail secure. Fail safe versions allow exit in the event of power failure. Fail secure versions do not. Consult with the local authority having jurisdiction concerning the installation of this type of product and whether listed panic hardware is required to allow emergency exit from the secured area.

OPTIONAL FEATURES

- LBM SWITCH (Latch Bolt Monitor)**
A switch operated by the switch tripper that signals whether or not the latch bolt is extended into the strike.
- LCM SWITCH (Locking Cam Monitor)**
A switch operated by the LCM switch tripper that monitors the position of the locking cam and signals that the strike is either locked or unlocked.
- LCBM SWITCH (Locking Cam and Latch Bolt Monitor)**
A switch operated by the LCM switch tripper and the LBM switch tripper that signals that the strike is locked and the latch bolt is engaged.
- LCBMA SWITCH (Locking Cam and Latch Bolt Monitor, wired separately)**
This is the same as the LCBM, with an additional switch operated by the LBM switch tripper.
- KEEPERS**
There is a standard type for each model 300 strike, optional keepers are available for some models (see chart below).

Model	Standard Keeper	Optional Keeper
310-1	1/2	3/4, PK, U, 1
310-2, -2RF, -2W	1/2	PK
310-2 3/4, -2 3/4OB	3/4	NA
310-2 3/4U	3/4U	NA
310-3-1, -3-1DBS	1	NA
310-4, -4W, -4DBR, -4-1, -4-2, -4-3, -4-30	PK	1/2
310-4-100	PK	1/2
310-5	1/2	NA
310-6-8, -6-1, -6-2, -6-3, -6-30	1/2	PK
- SOLENOID VOLTAGE**
24VAC is standard. Optional voltages available are: 12 or 115 VAC, 6, 12, 24, 48 or 115 VDC.

NOTE: UL requires that a junction box be used with 48 and 120 volt strikes, if they are not installed in a back box.
- SILENT OPERATION (SO)**
Silent operation is recommended for AC non-fail-safe strikes that are to be energized for extended periods of time. All silent operation strikes are operated by DC solenoid.

When control power source is AC, the strike is supplied with an externally attached bridge rectifier.
- FAIL-SAFE**
The strike is locked when energized. This feature should be used for applications that require automatic unlocking in case of power failure. All fail-safe strikes are operated by DC solenoid and are silent operation.

CAUTION: Fail-safe is **not** permitted with the UL Fire Door Accessory label.
- MOUNTING TAB**
The mounting tab is designed to be used with 310-2, 310-2 3/4, 310-3-1 and 310-6 electric strikes when mounting in metal frames.
- ASTRAGAL**
A lock guard, designed to prevent tampering with the strike keeper and the latch bolt.
- 310-2-107 WOOD MOUNTING**
A mounting for wood door applications. Available for the 310-2 strike only.
- EXTENDED LIP**
A lip extension is added to the face plate to form a path for the latch bolt when released electrically. Extension is available in increments of 1/4" up to 2" maximum. Available on models 310-2, 310-2 3/4, 310-2 3/4U and 310-3-1.

TROUBLE SHOOTING

- Strike does not operate when energized. Check for proper voltage being supplied to the strike. Check all wiring. Check the coil resistance of the solenoid and compare it to the chart located on the wiring diagram, to insure the correct solenoid is being used.
- Strike operates intermittently. Check for loose wire connection.
- Solenoid overheating or burned out. Check for proper voltage being supplied to the strike. If a rectifier is attached to the strike, check to insure the proper rectifier is being used. A tag on the rectifier identifies which strike and voltages the rectifier operates.
- Buzzing solenoid (when not specified). Realign solenoid on AC strikes (see ILL. 1 on page 2). Replace rectifier on DC strikes.
- Strike is not re-locking or is not unlocking. Check for proper alignment between strike keeper and bolt, realign face plate if necessary.

The keeper may not be returning to the fully locked position. Check the strike with the door open, if the strike re-locks check the horizontal alignment between the strike keeper and the latch bolt. There is a 3/16" horizontal adjustment between the strike assembly and the face plate (see installation instructions for adjustment). If vertical alignment is off, reposition the face plate.

Check the locking cam spring to insure it is moving the locking cam into the locked position (non-fail-safe) or the unlocked positions (fail-safe).

Check the solenoid assembly to insure the solenoid plunger is moving freely.
- Improper indication. (LCM, LBM or LCBM) Check wiring. Check latch bolt for correct engagement with the switch tripper. Check switch actuator arm, re-bend if necessary. Check continuity of indication switches, common to normally open, common to normally closed.
- Solenoid plunger binding in solenoid. (Plunger will not extend or retract.) Realign solenoid (see ILL. 1 on page 2).

**300 Strike
Installation Instructions**

 <p>FOLGER ADAM</p>	REF. REPAIR PART DWG.	
	P.O. BOX 25288, CHARLOTTE, NC 28229-8010	
TEMPLATE NUMBER	PAGE	DATE
089-0245-007	1 of 2	7-98

MAINTENANCE AND LUBRICATION

Under normal usage the 300 electric strike should be cleaned and lubricated once a year to maintain its reliability. In applications with high usage or dirty conditions more frequent service may be necessary. Lubrication points are identified in illustration 2. When servicing a 300, inspect the internal parts for excess wear or breakage and lightly lubricate per the instructions below. Lubricate with Lightning Grease, available from Folger Adam. Never lubricate any strike with oil, such lubrication collects dirt and forms an abrasive and sticky compound that may affect the function of the strike.

TO INSPECT AND LUBRICATE THE STRIKE:

1. Remove the strike from the face plate, held on by two (2) 12-24 x 3/8 HEX WASHER HEAD CAP SCS.
2. Remove the upper cover, held on by two (2) 4-40 x 3/16 PHMS. Removal of the upper cover should be done slowly because the locking cam spring may snap out of place. Also, care should be taken to insure that the locking cam spacer and locking lever spacer are not lost.
3. Remove the cam spring spacer, cam spring and locking lever spacer.
4. Loosen the two (2) 6-32 x 1/8 SSSC holding the solenoid, then remove the solenoid and locking cam.
5. Remove the locking lever spring and locking lever. In some versions of the strike, there is a recess in the locking lever and the case (effective first quarter of 1984) for this spring. In cases with the recess, the locking lever spring must be compressed into the lever before it can be removed.
6. Lubricate the area in the case where the locking lever and locking cam rest. (Be careful not to get any lubricant on the solenoid or switches.) Lubricate the cam pin and lever pin.
7. Check the locking angle of the keeper and locking lever for wear. Replace the keeper and/or lever if worn. (If the keeper is disassembled for replacement or adding of a switch, lubricate the keeper pin.)
8. Reinstall the locking lever and a new locking lever spring. CAUTION: Make sure the locking lever spring is placed back into the recesses of the locking lever and the case.
9. Check the solenoid, plunger and plunger guide for excess wear, dirt, grime or oil, if present wipe clean.

FAIL-SAFE: Remove the retaining ring for inspection of the plunger guide. Reassemble the solenoid and plunger with a new retaining ring.

NON-FAIL-SAFE: Lubricate the bottom edge of the locking cam (contact points of the solenoid plunger).

10. **NON-FAIL-SAFE:** Lubricate the slot in the locking cam.

FAIL-SAFE: Lubricate the bottom edge of the locking cam (contact point of the solenoid plunger).

11. INSTALLING AND ADJUSTING THE SOLENOID

NON-FAIL-SAFE:

1. Install the solenoid and locking cam assembly.
2. Install the locking cam spring (with the long leg of the spring on the locking cam and the short leg in the groove on the case).
3. Before tightening the set screws, energize the solenoid and check the position of the locking cam and locking lever.
4. Adjust the solenoid position to where the locking lever will clear the locking cam and tighten set screws.

FAIL-SAFE:

1. Install the solenoid and locking cam.
2. Install the locking cam spring (with the long leg of the spring on the locking cam and the short leg in the groove on the case).
3. Before tightening the set screws, energize the solenoid and check the locking cam position.
4. Adjust the position of the solenoid to where it pushes the locking cam into the fully locked position (be careful not to position the solenoid too high or the solenoid plunger will not seat).
5. De-energize and make sure the locking cam falls to a level to be unlocked, tighten set screws.
12. Check all screws, tighten if necessary. CAUTION: Do not over tighten the switch screws, over tightening could break the switch.
13. Reinstall the cam spring spacer and the locking lever spacer.
14. Reinstall the upper cover.
15. Reassemble the strike to the face plate.

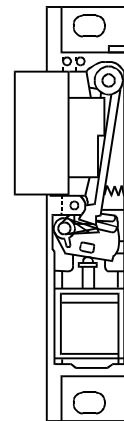

Front View
Fail-Safe
Shown Locked

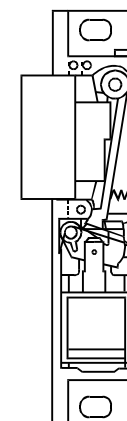

Front View
Non-Fail-Safe
Shown Unlocked

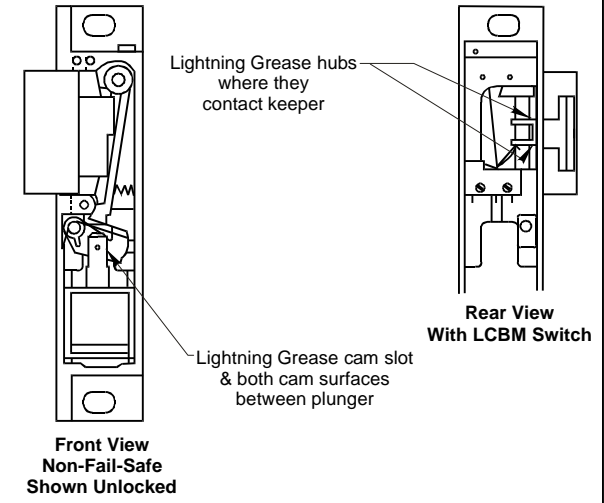

Front View
Non-Fail-Safe
Shown Unlocked

Rear View
With LCBM Switch

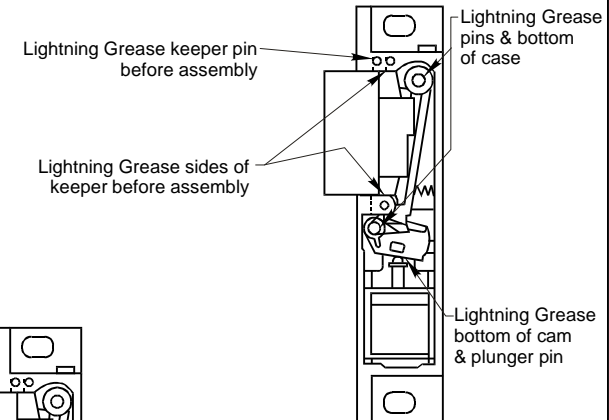

Front View
Fail-Safe
Shown Locked

300 Strike Installation Instructions



TEMPLATE NUMBER

089-0245-007

REF. REPAIR PART DWG.

P.O. BOX 25288, CHARLOTTE, NC 28229-8010

PAGE

2of2

DATE

7-98

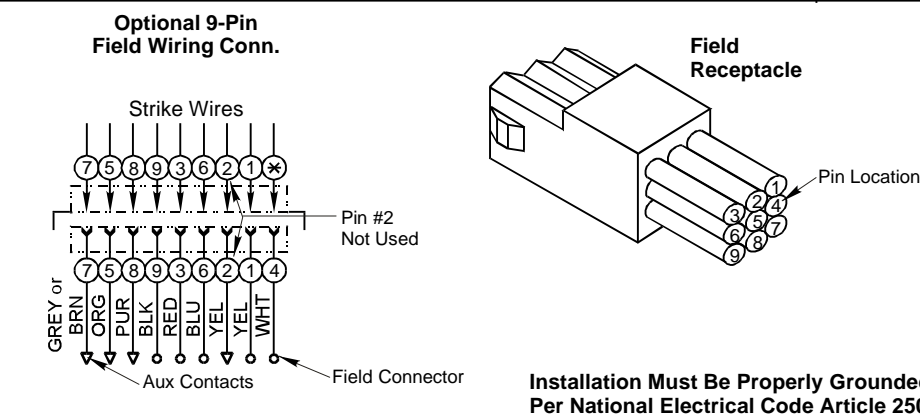
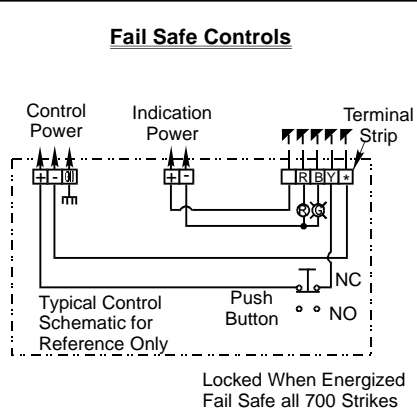
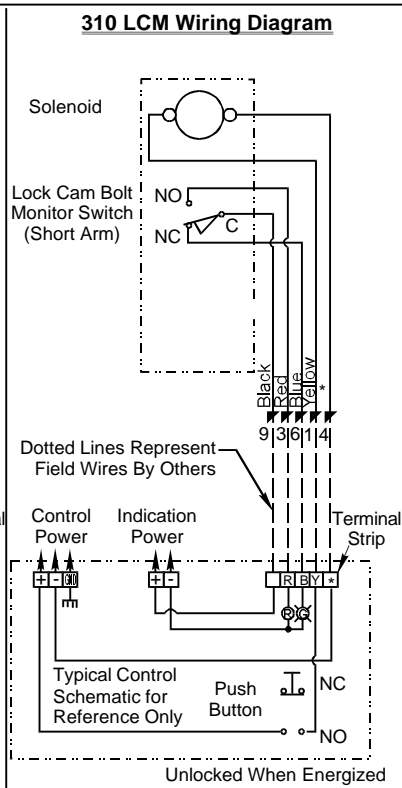
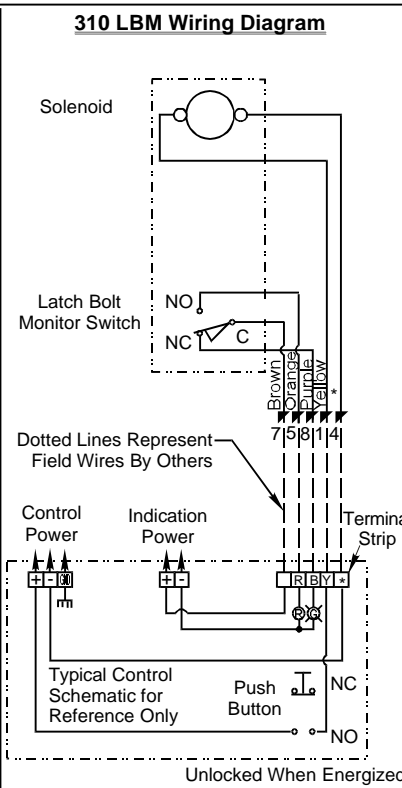
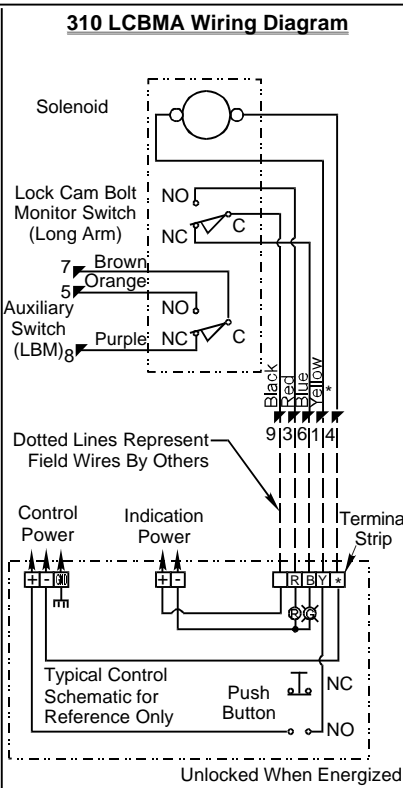
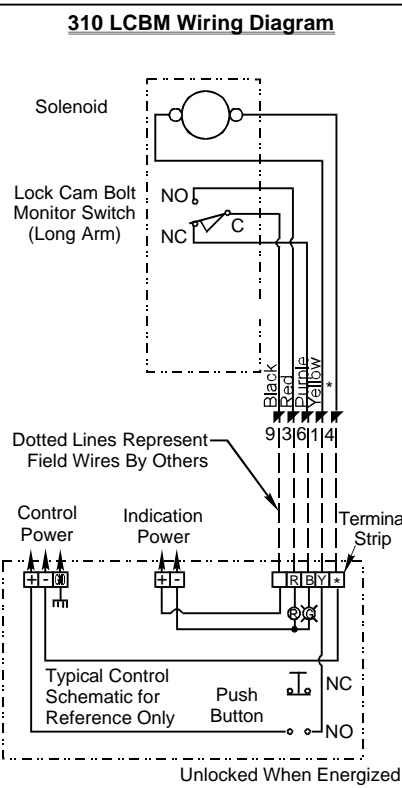
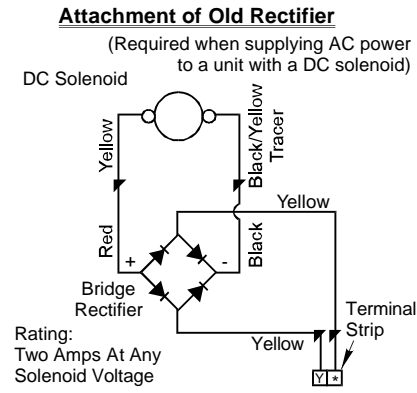
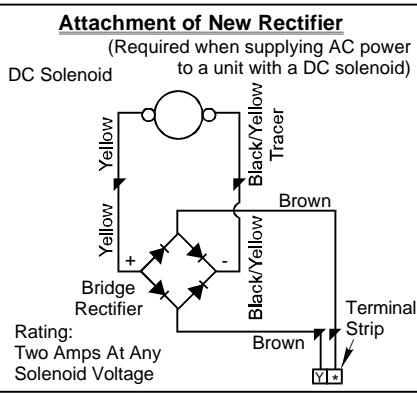

Electrical Ratings for All 310 Strike Solenoids	Voltage							
	AC				DC			
	12	24	120	6	12	24	48	120
Resistance in OHMS ± 10%	6.2	23.5	500	6.2	23.5	96.0	380	2100
Watts Seated	5.4	5.8	6.3	5.8	6.1	6.0	6.1	6.3
Amps Seated	.45	.24	.06	.97	.51	.25	.13	.06
Amps Inrush	1.33	.69	.16	N/A	N/A	N/A	N/A	N/A

- NOTES:**
- * = Wires color code: 6 thru 120 VDC Yellow/Black Tracer 12 & 24 VAC-Grey 120 VAC-White
 - Unused wires to be individually isolated with a wire nut or equal.
 - Numbered field connections refer to pin location in field receptacle.

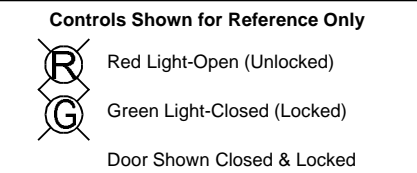

Notice:
Wiring Subject To Change Without Notice. Not Responsible When Controls Furnished By Others.

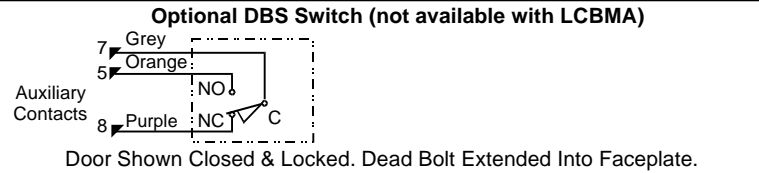
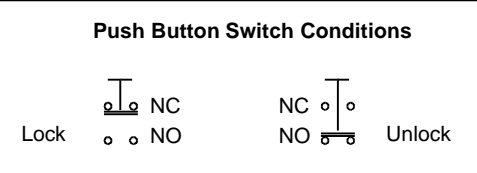

310 Wiring Diagrams