

NARROW FLOATING HEADER WITH SUPPORT FINNS

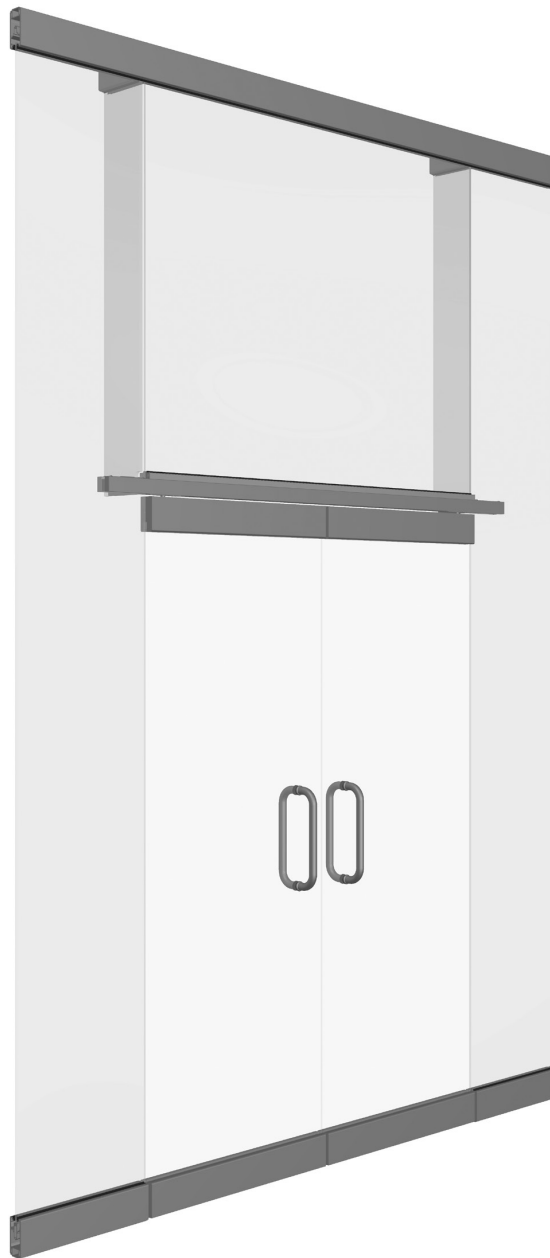

ORDER OF PREPARATION AND INSTALLATION

HEADER PREPARATION.....03-04

HEADER INSTALLATION.....05-07

The rapidly changing technology within the architectural aluminum products industry demands that C.R. Laurence/U.S. Aluminum reserve the right to revise, discontinue, or change any product line, specification, or electronic media without prior written notice.

NOTE: Dimensions in parentheses () are millimeters unless otherwise noted.

Tools Required

- | | |
|---------------------------|------------------------------|
| Tape Measure | Framing Square/Straight Edge |
| Saw Horses | 7/16" Socket head wrench |
| Cordless Drill | |
| Flat Head Screwdriver | |
| Phillips Head Screwdriver | |
| Rubber Mallet | |
| 3/4" Masking Tape | |
| Stepladder | |

NOTE: Modifications, other than those specified in this document, could result in failure to meet UL safety ratings and void the manufacturer's warranties.

HEADER PREPARATION

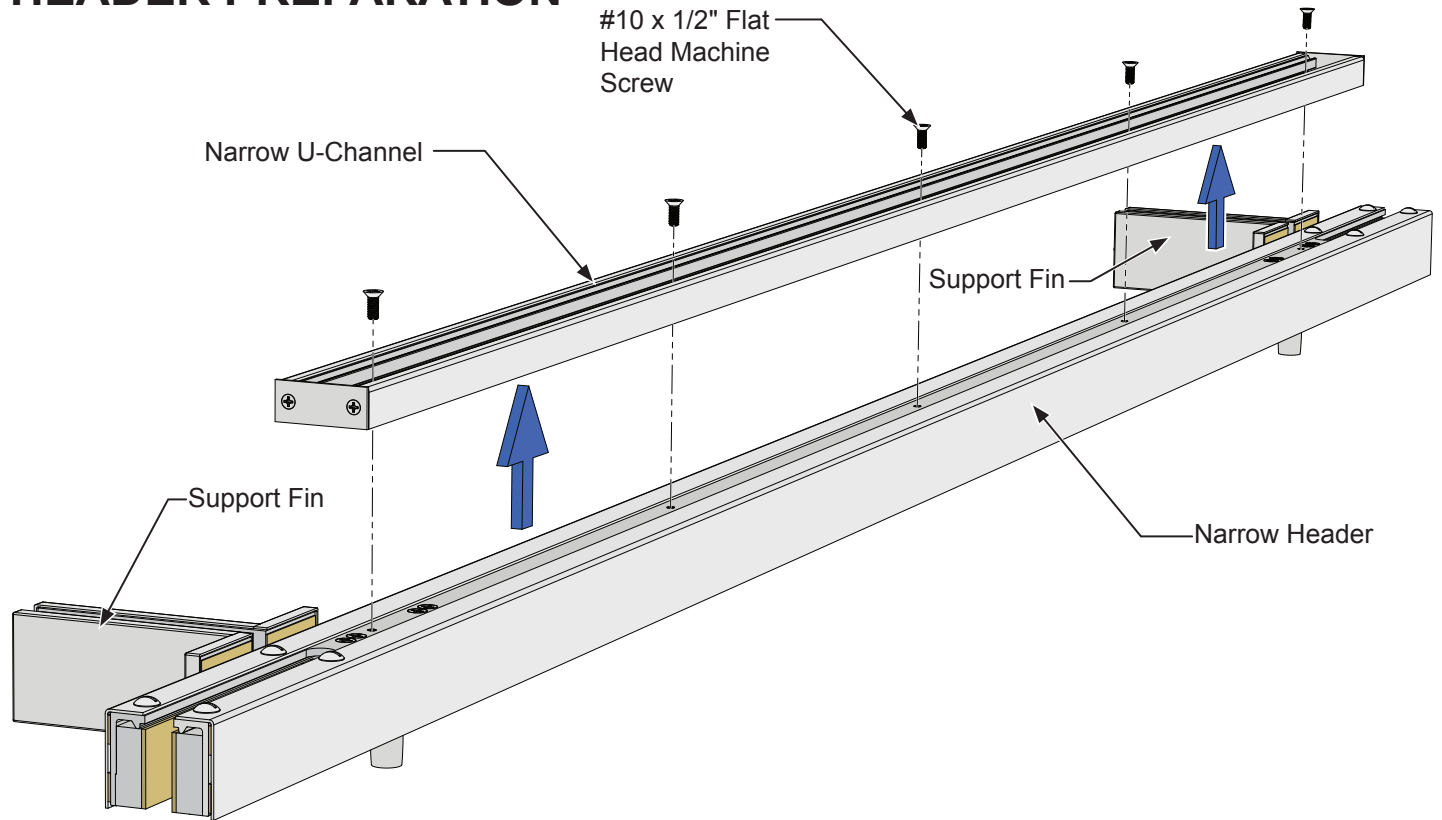

1. Remove the #10 x 1/2" Flat Head Machine Screws and separate the Narrow U-Channel from the Narrow Header.

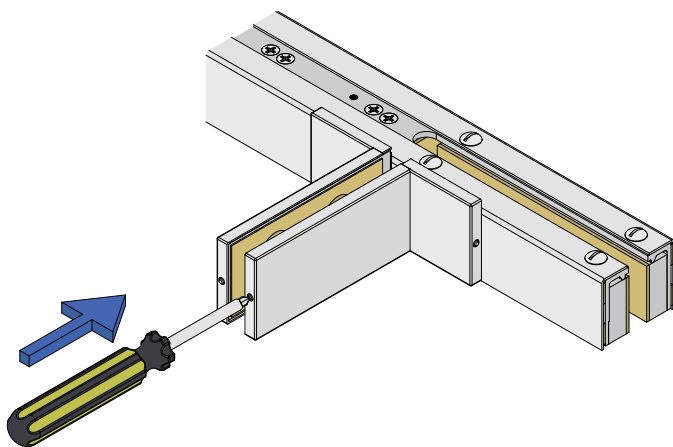

2. Remove the Patch Fitting Covers by Pushing in the cover tab with a screw driver.

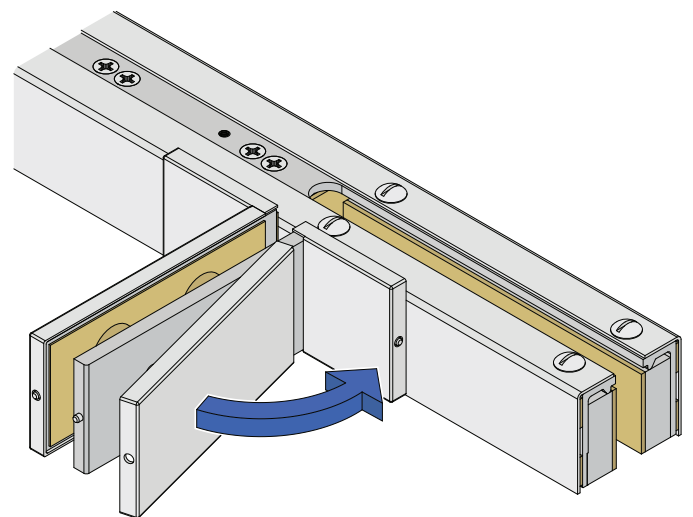

3. Once the tab is pushed in pull the covers off the Patch Fitting.

HEADER PREPARATION

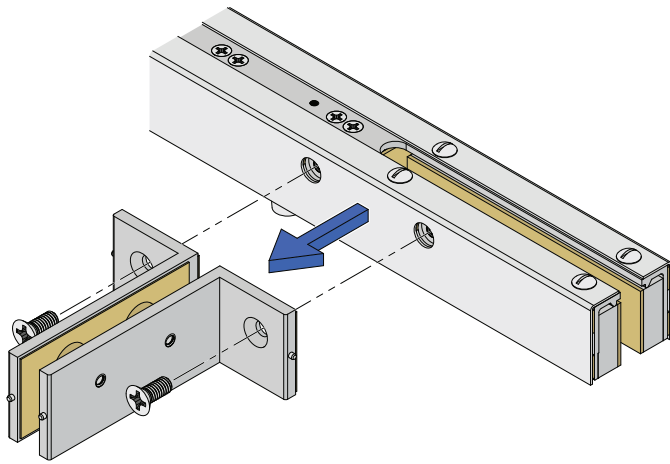

4. Remove the 5/16-18 x 3/4" Flat Head Machine Screws and detach the Patch Fittings.

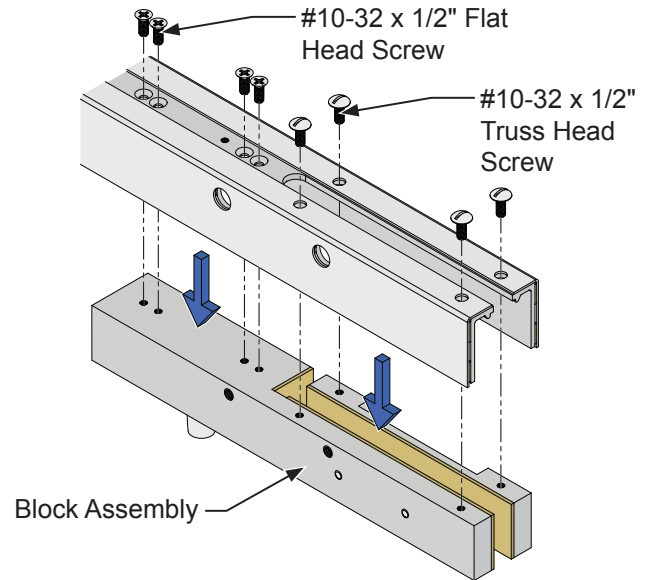

5. Remove the 10-32 x 1/2" Truss Head Screws and the 10-32 x 1/2" Flat Head Screws, detach the block assemblies from the header channel.

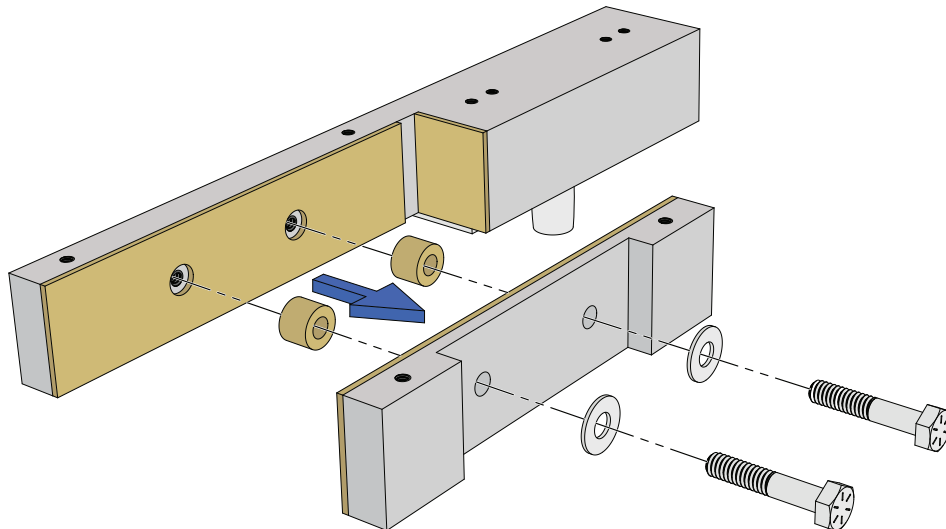

6. Remove the 1/4-20 x 1-3/8" Hex Head Screws and separate the clamp blocks and set aside.

NOT TO SCALE

HEADER INSTALLATION

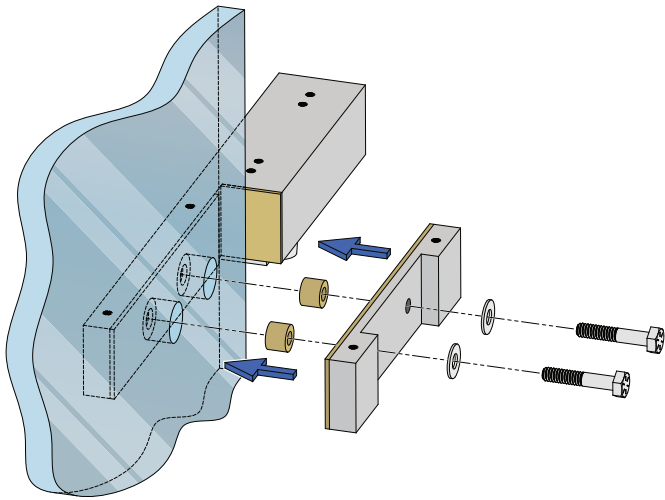

7. Insert the glass grommets into the holes in the sidelite glass, align the clamp blocks with a level and secure with the 1/4-20 x 1-3/8" Hex Head Screws.

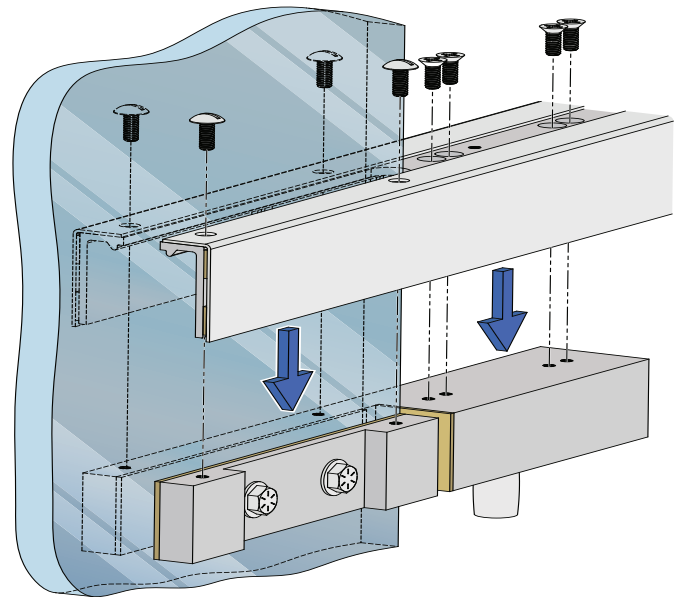

8. Install the Floating Header Beam onto the glass clamps and secure with the 10-32 x 1/2" Truss Head Screws and the 10-32 x 1/2" Flat Head Screws.

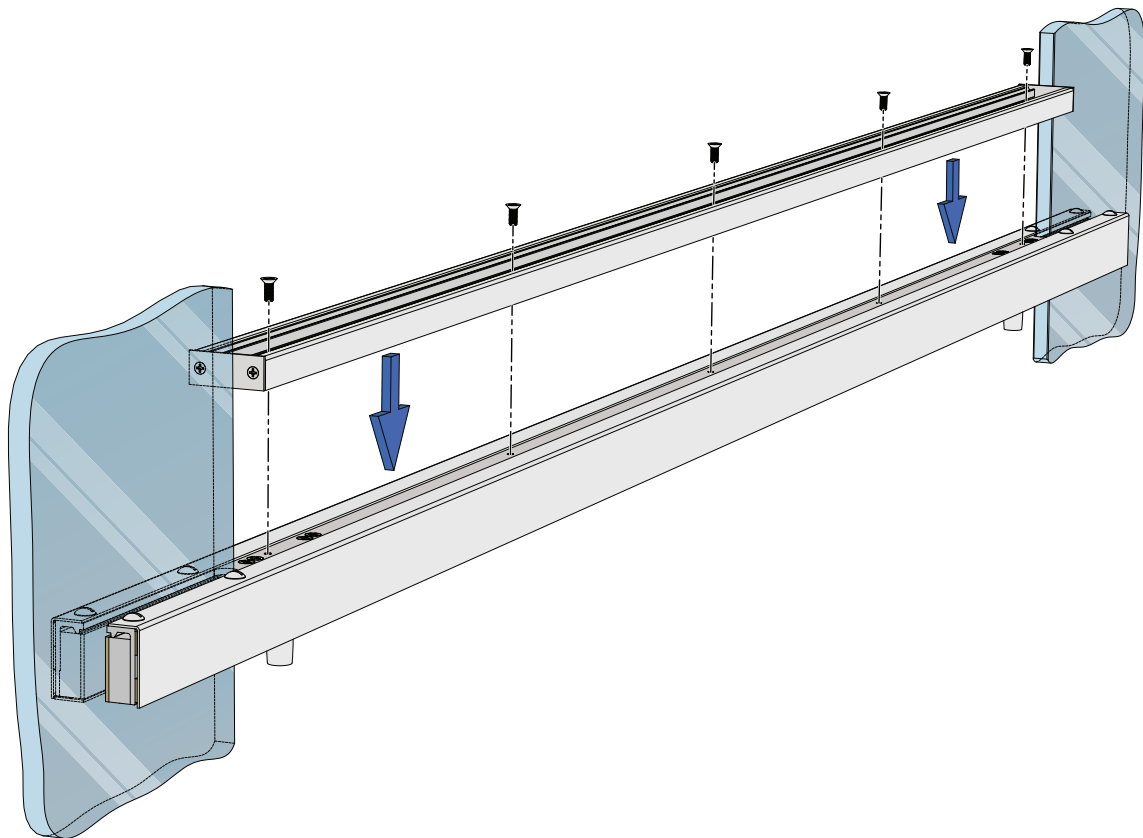

9. Mount the Narrow U-Channel onto the Beam and secure it with #10 x 1/2" Flat Head Machine Screws.

NOT TO SCALE

HEADER INSTALLATION

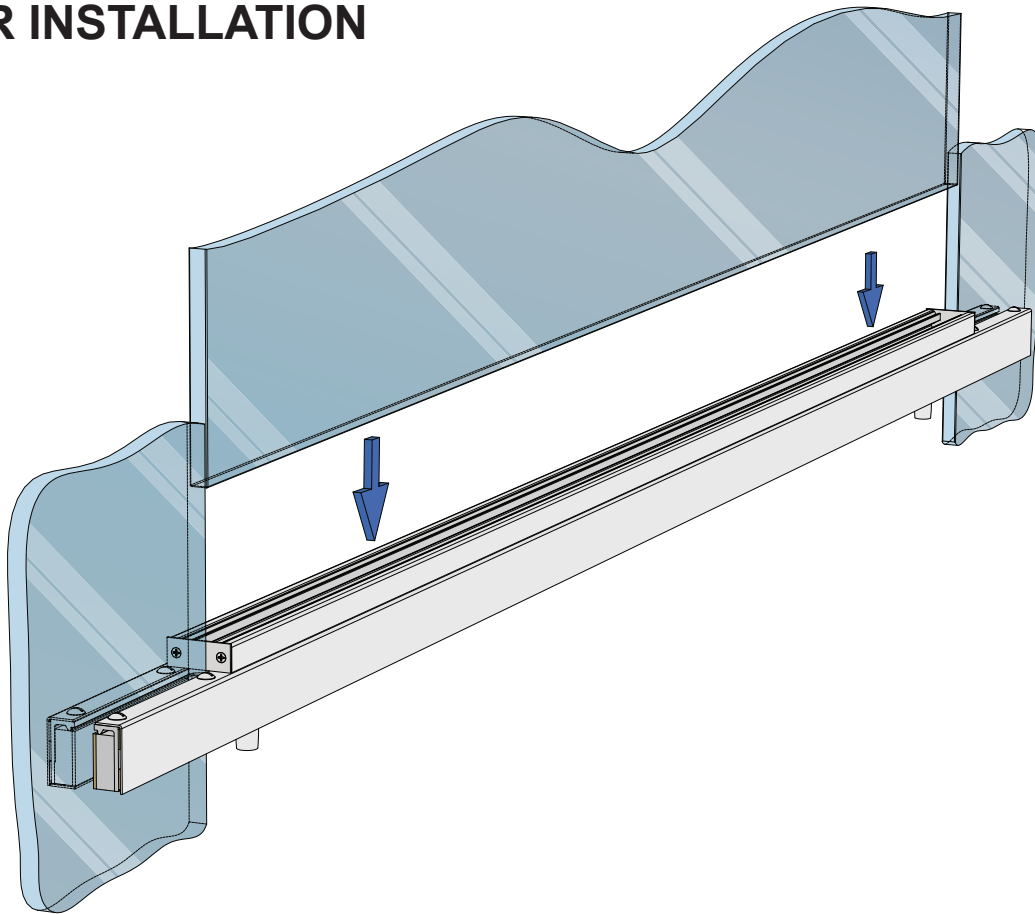

10. Insert the Setting Blocks and install the Transom Glass into the Narrow U-Channel and secure with the glazing gaskets.

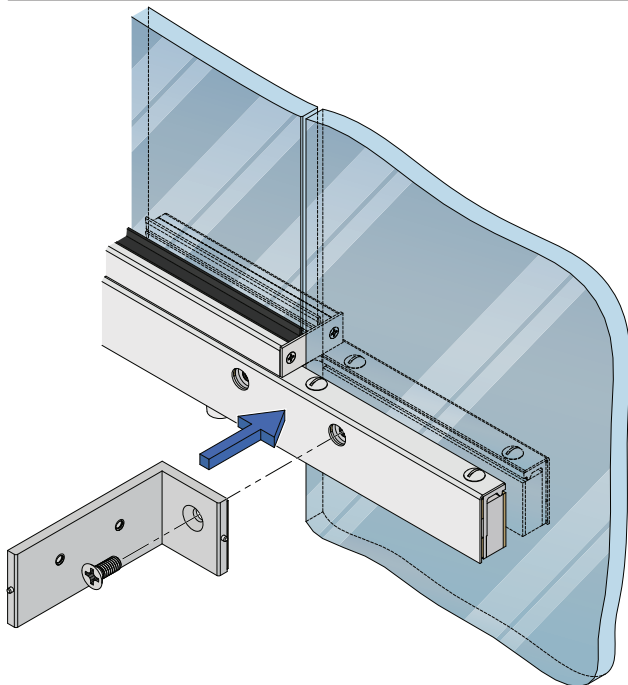

11. Secure the Patch Fitting with 5/16-18 x 3/4" Flat Head Machine Screw.

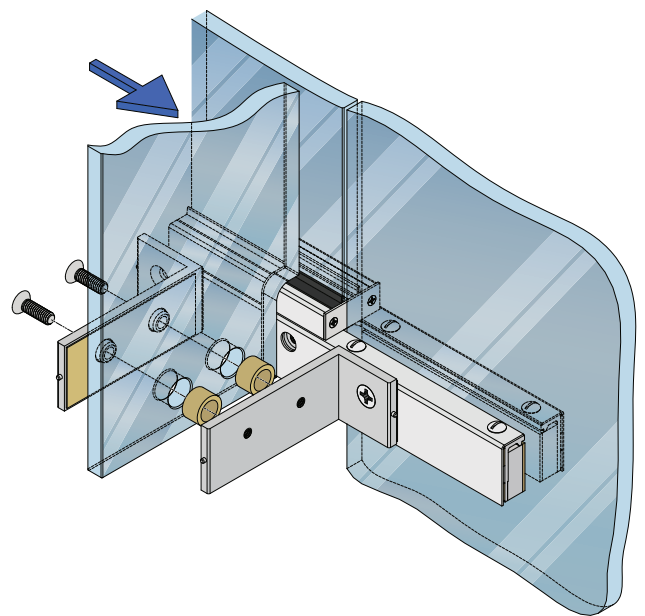

12. Install the glass fin and secure it with 5/16-18 x 3/4" Flat Head Machine Screws.

NOT TO SCALE

HEADER INSTALLATION

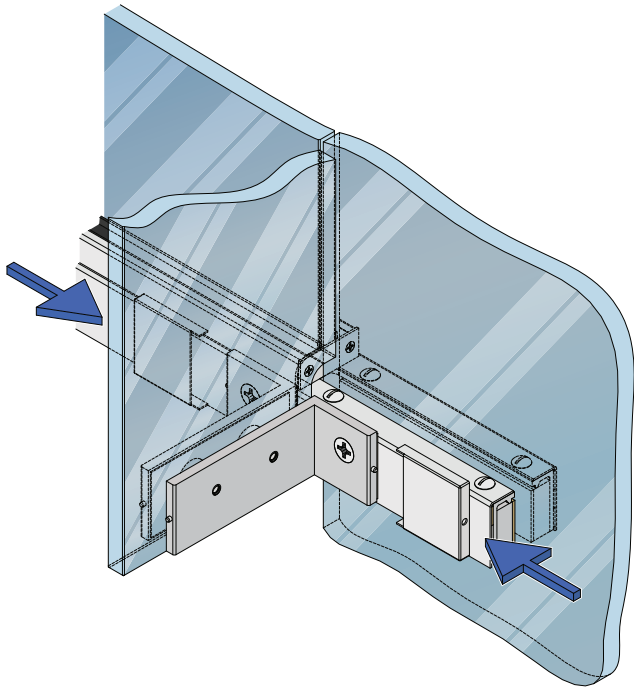

13. Insert the small Patch Fitting Covers by sliding them onto the cover tab.

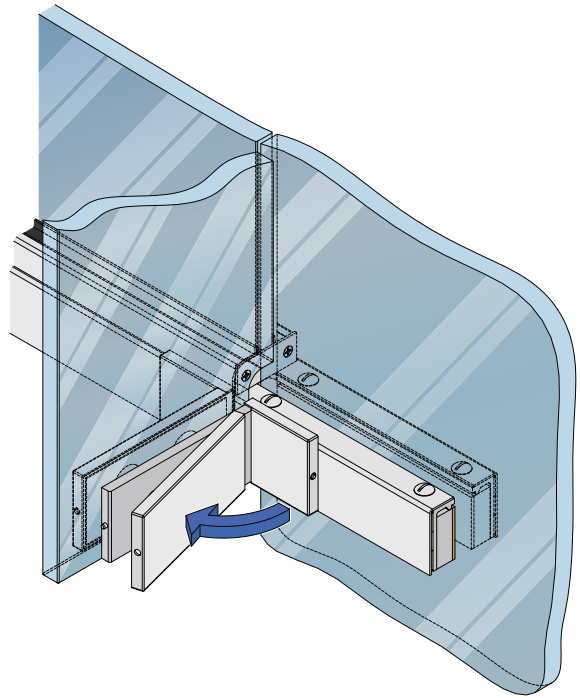

14. Secure the Covers by snapping the long Covers over the cover tab.

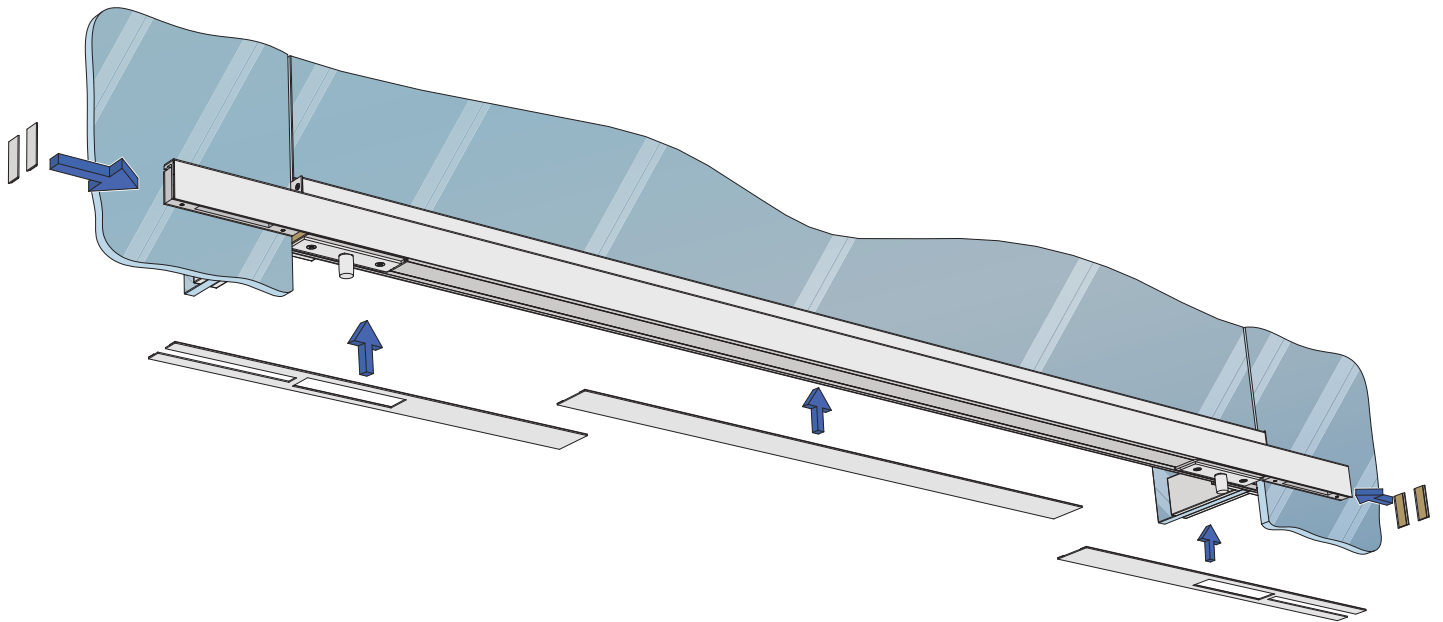

15. Remove the backing paper from the UHB Tape and install the Pivot Cover Plates, Header Cover Plate and End Caps.

NOT TO SCALE