

## **CRS Installation Instructions** **Surface and Fascia Mounting**

### **Tools and Supplies Needed:**

- **Saw and Blade for Cutting Stainless Steel**
- **Smooth Cut Metal File Cat. No. FF12SC**
- **Metal Cleaning Solvent Cat. No. MEK1GL**
- **Cat. No. 32629 Adhesive and 7075 Activator**
- **Folding Post Level Cat. No. 34008**
- **Measuring Tape Cat. No. 54225**
- **Chalk Line Cat. No. ST47099**
- **Caulking Gun Cat. No. ER3**
- **Black Silicone Building Sealant Cat. No. 95CBL**
- **2" Wide Masking Tape Cat. No. 4032**
- **5/32" Allen Wrench Cat. No. 91**
- **Single Edge Razor Blades Cat. No. 51S**
- **Glass Cleaner Cat. No. 1973**
- **Lint Free Glass Wipes Cat. No. BX15**
- **Vacuum Cup Cat. No. W4950**
- **Glass Handling Gloves Cat. No. KF1TM**
- **Tools and Fasteners for Attachment to the Building**



# Steps:

## 1) Post Installation:

**1a.** Snap a chalk line along the railing's centerline on the floor. Position a corner or end post and the next post in line, and center them on the chalk line.

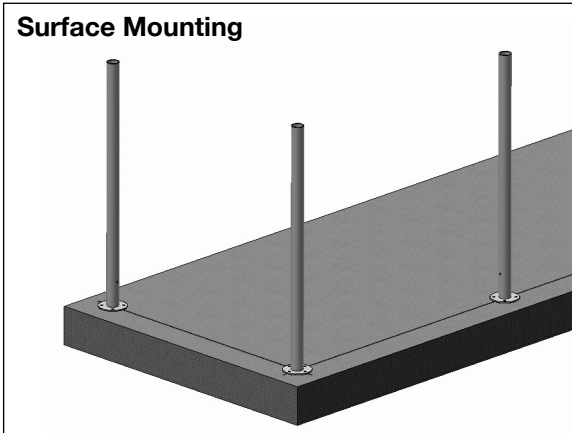

**Note:** When fascia mounting posts, the building structure will establish the horizontal alignment. A line should be laser projected, or a chalk line snapped along the building structure at the base of the Fascia Mount Brackets. This will align the tops of the posts, which should be set at 38" (965 mm) above the FINISHED FLOOR (consult local codes). If the finished flooring material has not yet been applied, add the flooring material thickness to the 38" (965 mm) post height dimension when measuring from sub-flooring. Attach Fascia Brackets to structure using proper fasteners based on substrate and job specific engineering.

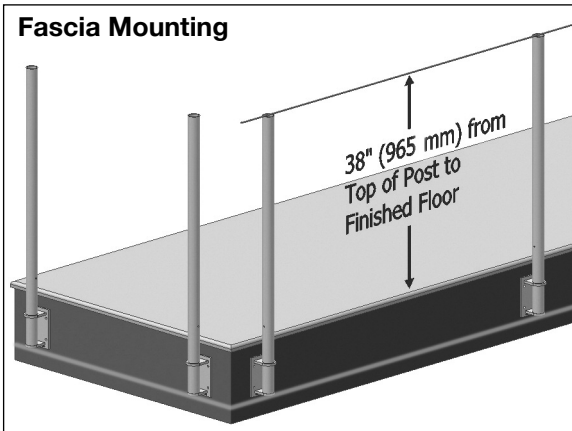

**1b.** The posts now need to be connected together using the bottom cap rails. This will control the post spacing and rotation.

## 2) Install Bottom Cap Rail:

**2a.** The Bottom Rail Adapters are packaged with a fastener and post-mounting bracket. Using a 5/32" Allen wrench, attach the mounting brackets to the posts using the pre-drilled and tapped holes near the base of each post.

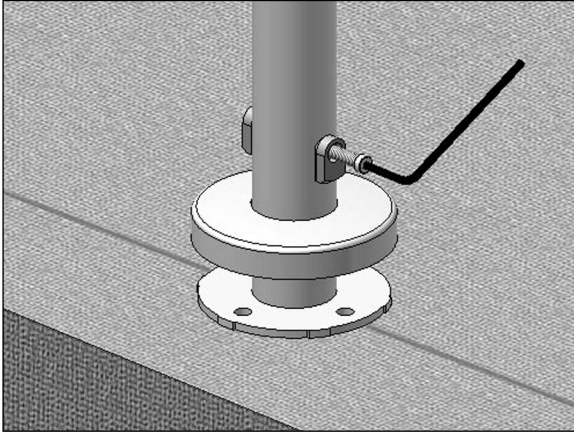

**2b.** Pre-cut Cap Rail can be used to avoid field cutting.

**Important Note:** 5' (1524 mm) is the maximum allowable post spacing. If the Cap Rail must be field cut, measure between the Rail Adapters on a pair of posts and cut a length of 1-1/2" (38.1 mm) diameter Cap Rail to that dimension. Deburr the ends of the Cap Rail, and remove the Rail Adapters from the Mounting Brackets. Dry fit the Rail Adapters into the Cap Rail, and then dry fit onto the Mounting Brackets. Check for proper fit and correct if necessary, disassemble. Take care so as to not damage the finish on the posts.

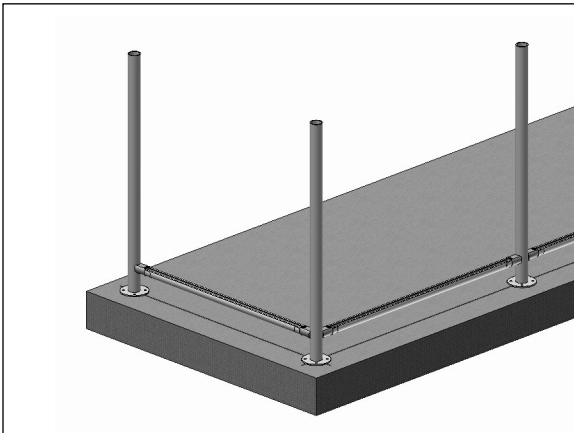

**2c.** Surfaces to be bonded should be cleaned with Cat. No. MEK1GL Solvent. Please follow the bonding instructions on the Cat. No. 32629 Adhesive and Cat. No. 7075 Activator packaging.

**2d.** Bond the Rail Adapters to the Cap Rail. The Bottom Rail assembly should then be bonded to Mounting Brackets by applying activator to the receiving pockets of the Rail Adapters and also the Mounting Brackets. Apply a small amount of adhesive to the top of the Mounting Brackets. Bonding the Rail Adapters to the Mounting Brackets is an important step.

**2e.** Slip the Rail Adapters with Cap Rail down over the Mounting Brackets until completely engaged. Take care so as to not damage the finish on the posts.

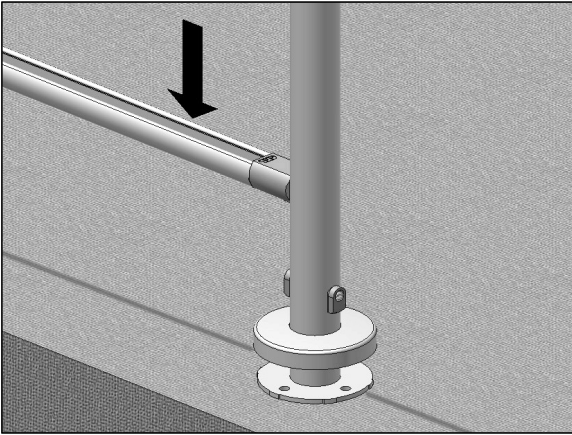

**2f.** Reposition the post / bottom rail assemblies over the chalk line or into Fascia Brackets. The post spacing and rotation is now set, and the assemblies are ready for attachment to the building structure.

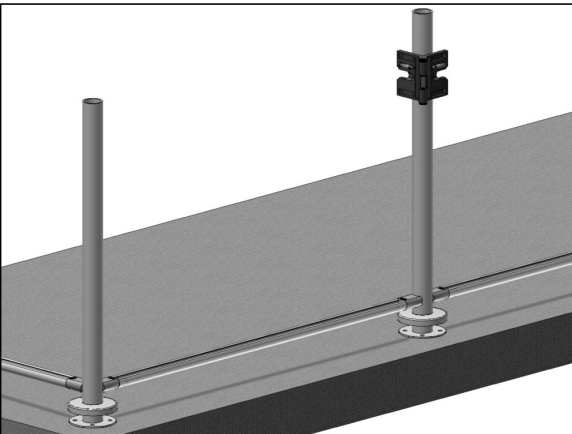

**2g.** Attach the posts to the structure using proper fasteners based on substrate and job specific engineering. During the attachment process, the posts or Fascia Brackets should be shimmed until posts are plumb. The Cat. No. 34008 Folding Post Level will aid in this operation. Shim as required until the level indicating bubbles are centered between the marks on both horizontal glass tubes.

**3) Install Top Rail Adapters:**

**3a.** Identify the correct Top Rail Adapter for each post.

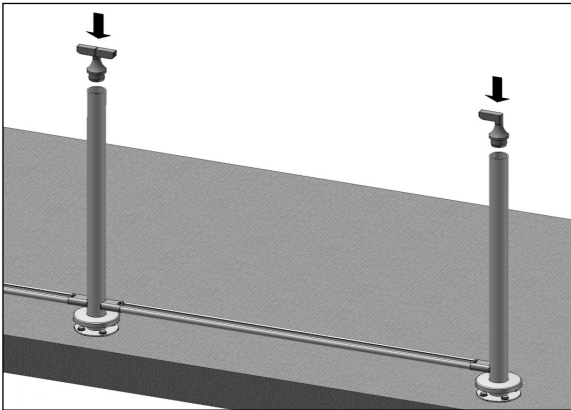

**3b.** Place a straight edge or string line along side of the indicated surfaces to act as a guide for aligning the adapters.

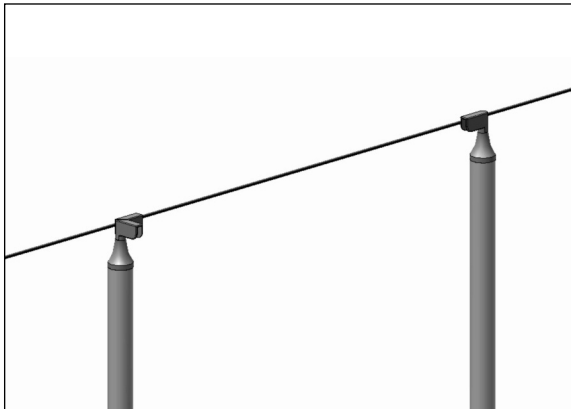

**3c.** Following the bonding instructions on the Cat. No. 32629 Adhesive packaging, apply bonding, then quickly move to correct the rotation of each adapter. Always spray the Cat. No. 7075 Adhesive Activator to all bonding surfaces. If the floor is a finished surface, protect it from drips of adhesive.

#### 4) Install Top Cap Rail:

**4a.** First, dry fit the Cap Rail with Sleeves and Corner Fittings, and place over the Top Rail Adapters. Then disassemble in sections for bonding. Bonding of the sleeve connections can be done after a preceding section has already been bonded. It is best to bond together as many Cap Rail sections as possible, before bonding the assembly to the Top Rail Adapters. While slipping together the sleeve connections, take care to keep the Cap Rail assembly from coming into contact with the applied adhesive on the Top Rail Adapters. This can be accomplished by holding the Cap Rail assembly at a very slight incline, above the adhesive.

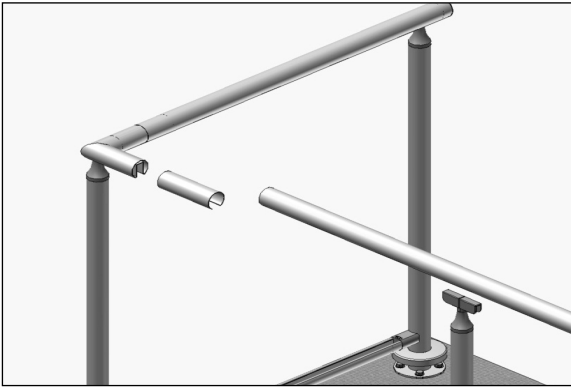

**4b.** Surfaces to be bonded should be cleaned with Cat. No. MEK1GL Solvent. Please follow the bonding instructions on the Cat. No. 32629 Adhesive and Cat. No. 7075 Activator packaging.

**4c.** Apply the activator to both bonding surfaces and allow drying for the prescribed amount of time. When bonding the Top Cap Rail to the Top Rail Adapters, apply two parallel beads of adhesive to the top surface of the Top Rail Adapter as illustrated. Adhesive at this location will minimize dripping and at the same time will produce a strong bond.

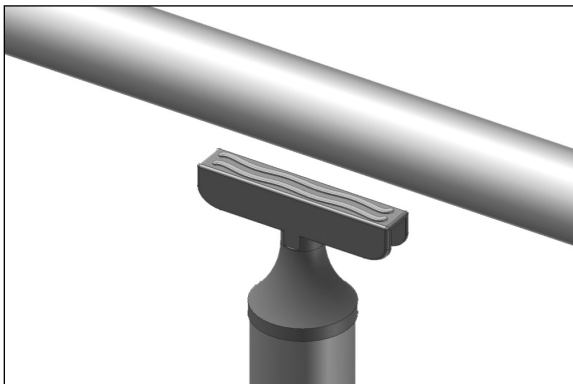

**4d.** Push the Cap Rail down until fully seated onto the Top Rail Adapters, and hold in place while applying 2" (50.8 mm) wide masking tape to the side of the post, then wrap over the Cap Rail and back down to the other side of the post. This will hold the Cap Rail down during the curing time.

**5) Install Cap Rail Vinyl:**

**5a.** Before cutting vinyl, please note that the Top Cap Rail Vinyl has a deeper pocket than that of the Bottom Cap Rail Vinyl. Also, verify that the pocket width of the Vinyl is correct for your glass panel thickness. CRL supplies vinyl for both 3/8" (10 mm) and 1/2" (12 mm) thick glass.

**5b.** Measure between the Bottom Rail Adapter Fittings in the interior of the Bottom Cap Rail's glass receiving pocket, and cut a piece of vinyl to fit. Push the vinyl into the pocket until it bottoms out.

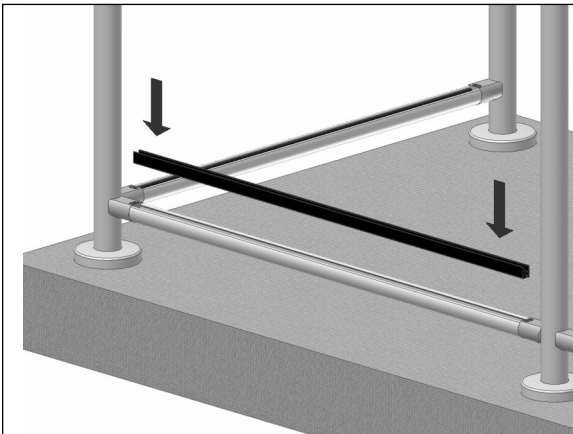

**5c.** Repeat this process for the Top Cap Rail.

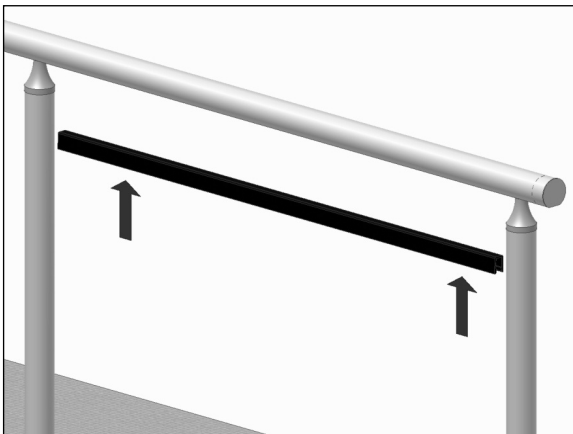

**6) Glass Sizing:**

**6a.** The following applies to both 3/8" (10 mm) and 1/2" (12 mm) thick glass, as well as stairs and ramps. Width is determined by measuring side to side between the posts, parallel to the Cap Rail, and then subtracting 4" (102 mm).

**6b.** Height is determined by measuring the opening between the Top and Bottom Cap Rails, at 90 degrees to the Cap Rails, and then adding 1-3/16" (30.1 mm). This will allow 3/16" (4.8 mm) clearance between the glass panel's bottom edge and the Bottom Cap Rail while setting the glass.

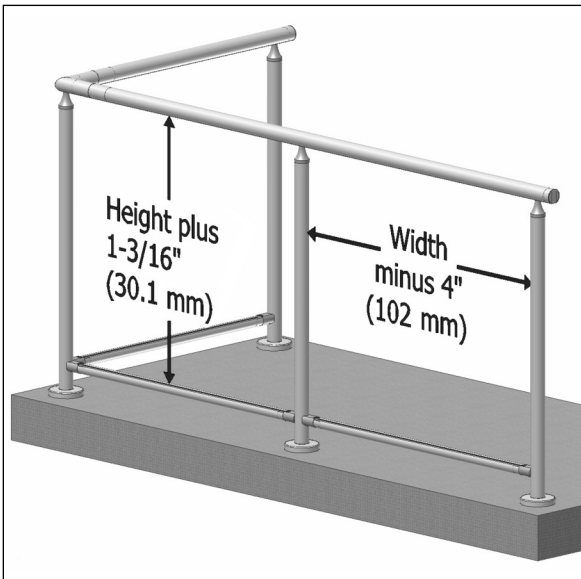



## 7) Glass Installation:

**7a.** Verify the glass panel size, form, and condition. The vertical edges should be polished. Polishing is not required for the top and bottom horizontal edges, but seamed edges are recommended.

**7b.** Using a suction cup or glass handling gloves, lift the glass up into the Top Cap Rail's pocket, swing the bottom in, centering it over the Bottom Cap Rail's pocket, and then lower into the vinyl pocket.

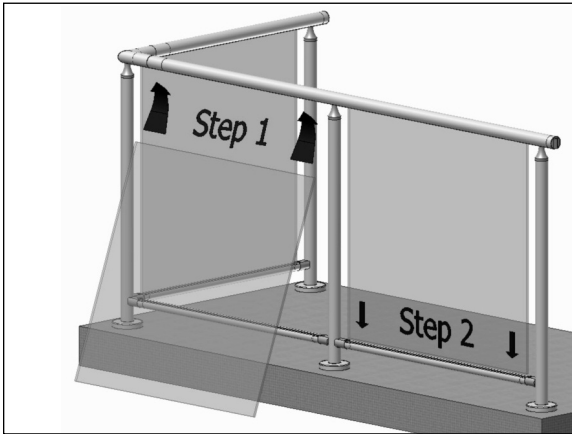

**7c.** If a vertical edge alignment adjustment is necessary, place a thin setting block under one corner of the glass.

**7d.** Verify that the top edge of the glass has at least 1/2" (12.7 mm) penetration into the Top Cap Rail Vinyl.

**7e.** Each of the Bottom Rail Adapter packages contains a 3/16" (4.8 mm) thick rubber spacer block. Place each spacer block between each of the Bottom Rail Adapters and a glass panel vertical edge. These blocks should be recessed enough to apply a cap bead of 95CBL Silicone.

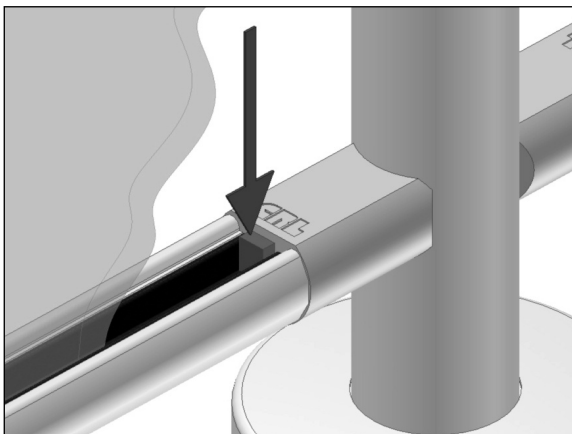

## 8) Pocket Filler Channel Installation:

**8a.** Two Pocket Filler Channels are supplied with each Top Adapter. These Filler Channels insert into the Top Cap Rail's pocket between the Top Adapter and the edge of the glass panel.

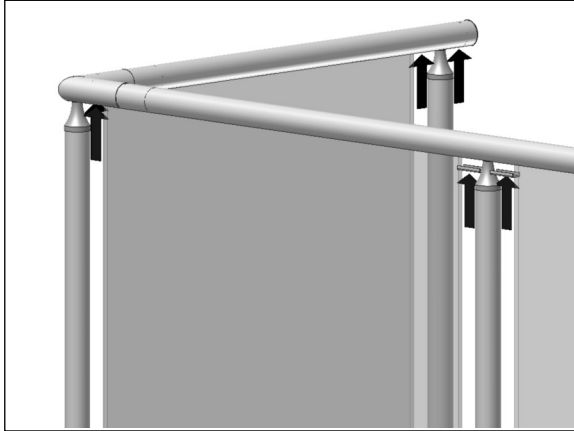

**8b.** Apply a small amount of Cat. No. 7075 Activator and Cat. No. 32629 Adhesive at the entrance of the Top Rail's pocket and insert the Filler Channel.

**8c.** Use one wrap of masking tape to hold the Filler Channel in place until the adhesive sets.

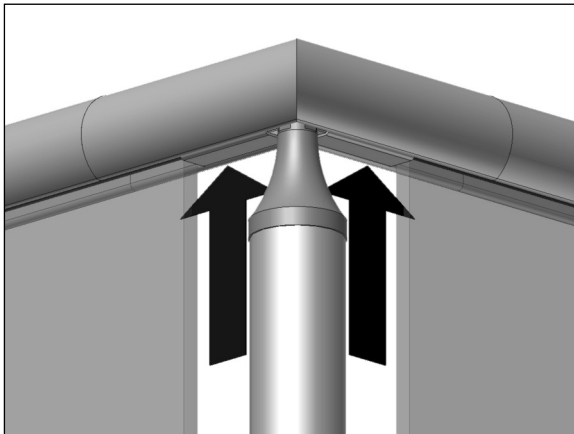

**9) Silicone Seal the Glass Panels:**

**9a.** We recommend the use of Cat. No. 95CBL Black Silicone Building Sealant, as this Neutral Cure Silicone has a low sheen, resulting in a better appearance as compared to the high gloss obtained from other grades of silicone.

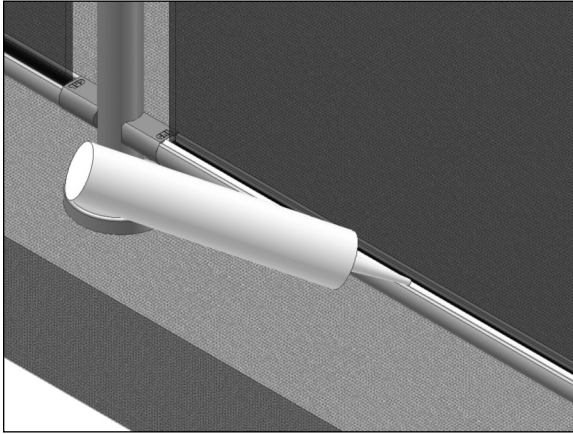

**9b.** Apply the bead of silicone to both sides of the glass, both top and bottom. Be sure to inject the silicone deep enough to come into contact with the Cap Rail Vinyl.

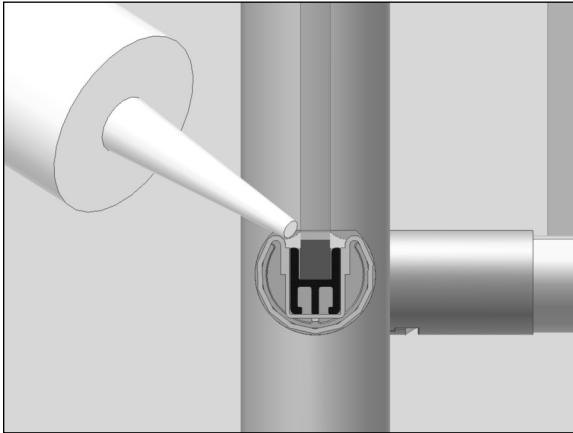

**10) Clean Up:**

**10a.** The adhesive used to attach Post Fittings and Cap Rail may leave amber colored runs and drips. These are easily wiped away with a shop towel and small amounts of the Metal Cleaning Solvent Cat. No. MEK1GL. Avoid allowing this solvent to come into contact with non-metallic surfaces and the silicone sealant.

**10b.** Clean the glass panels with Cat. No. 1973 Glass Cleaner and Cat. No. BX15 Lint Free Glass Wipes.



**crlaurence.com**

**Phone Toll Free (800) 421-6144**

**Fax Toll Free (800) 262-3299**