

## VIENNA

Wall Mount Hinge – Offset Back Plate

CAT. NO. V1E044

**\*NOTE:** Do not exceed either maximum weight or width when choosing proper quantity of hinges.

### Important Information:

This hinge contains a dual degree pivot pin. The pivot pin is set for normal door closing position. You have the option of altering the closing position of the door 5 degrees inward by utilizing the opposite side of the pivot pin, which has been pre-machined (see Section 3 of Cat. No. SDT22 Frameless Shower Door Guide for this procedure). Special order custom pivot pins are available (Cat.No. VIEPIN) that can be machined at any angle up to 45 degrees.

### Specifications:

Glass Sizes:	3/8" (10mm) to 1/2" (12mm) thick tempered safety glass
Construction:	Solid brass
Closing Type:	Self-centering when within 15° of closed position
Cutout Required	
Includes:	Gaskets, screws and template

### Maximum Door Capacities for Two Hinges or Three Hinges

Maximum Door Weight:	100 lbs.(45 kg)	130 lbs.(59 kg)
Maximum Door Width:	34"(86mm)	34"(86mm)

### Use of Gaskets:

For 3/8" (10mm) Glass: Use one thick gasket on each side

For 1/2" (12mm) Glass: Use one thin gasket on each side

### Recommendations:

For public safety, we recommend the use of only tempered safety glass. Do not use power tools when installing these hinges.

### Maintenance Guidelines:

- Our hinges are greased at the factory for quiet and trouble-free operation. If there is any squeaking that occurs after installation, put a drop of "3 in 1 Oil" (also known as "household oil") on the white nylon washer that the hinge body pivots on. This washer is the component that acts as a buffer, so the body of the hinge doesn't pivot directly on the brass center block. This solution doesn't require the disassembly of the hinge. **Note: Do not use spray lubricant on these hinges.** If the hinge has been disassembled, upon re-assembly, use white lithium grease to lubricate the interior mechanism.
- Never use an abrasive cleaner on the hardware. Many of the components are coated with a clear lacquer that will be irreparably damaged if subjected to harsh, abrasive chemicals. Advise your customer that drying the hardware with a clean, soft towel on a daily basis is the best way to maintain the hardware. If mineral deposits build-up, mix a couple of drops of a mild liquid soap (such as Ivory or a similar product) into a cup of warm water. Using a soft, non-abrasive cloth, clean the hardware. Rinse thoroughly with clean, warm water and dry.

**IMPORTANT:** Project measurements from the edge of the glass.

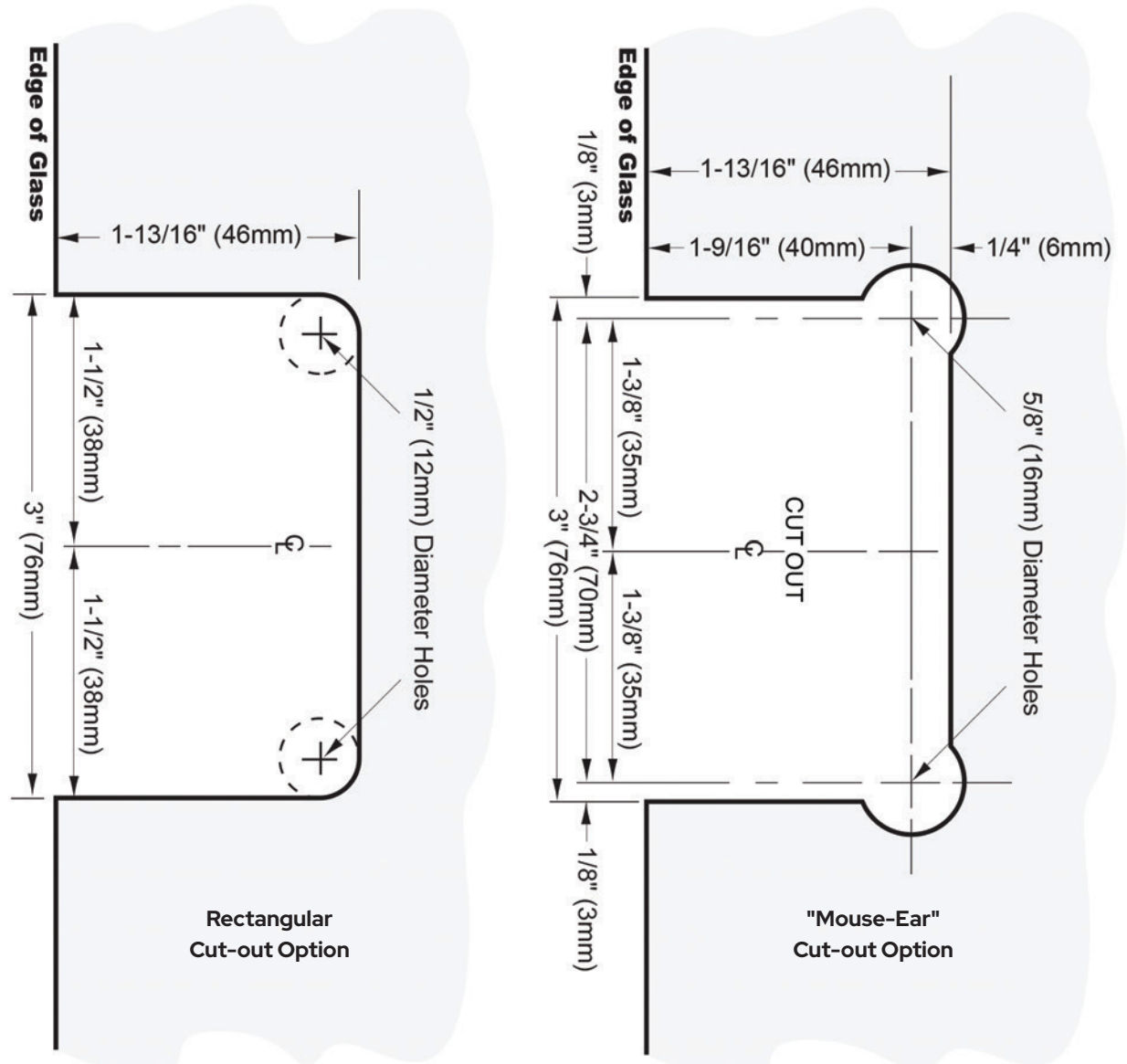

 ALWAYS USE DIMENSIONS TO ENSURE ACCURACY

**VIENNA**  
 Wall Mount Hinge – Offset Back Plate  
 CAT. NO. V1E044

## Troubleshooting/Best practices

1. As a preventive measure, or if the shower door is falling out of adjustment, setting blocks can be used to hold the glass in place to make sure the glass doesn't slip. Insert a hard setting block with a durometer rating of 85-90 between the body of the hinge and the glass cutout. This creates a physical barrier that helps secure the hinge in place, significantly reducing the likelihood of future movement or misalignment.

### Situations to consider blocking

- For high-traffic commercial installations, especially in large-scale projects.
- When installing large doors that rely on glass-to-glass hinges.
- When working with glass cutouts that are near the maximum allowable size tolerances.

**Note:** Be sure the setting block is sized correctly to avoid putting excessive pressure on the glass. CRL offers a range of setting blocks from 1/16" to 3/8" thicknesses. Visit [www.crlaurence.com](http://www.crlaurence.com) for setting block parts.

2. When making deductions for door glass sizes, determine if seals are to be used, as their inclusion can affect glass sizing. If a seal is to be used adjacent to a door, the gap required for the seal may be larger than if no seal were used.
3. Apply a medium-strength threadlocker to the clamping screws to promote a secure hold.
4. Do not use power tools when installing these hinges.

**Max Clamping Screw Torque: 60-70 lbf-in (677.99.790.9 cN-m)**

### General Guidelines for Installation Safety

For public safety, we recommend the use of only tempered safety glass.

### Protect the installer

- Wear appropriate personal protective equipment (PPE) including protective eyewear.
- File all sharp edges on plastics and metal. Leave no sharp edges that could cause harm.
- Lift any heavy materials safely using proper techniques.
- Be OSHA compliant on jobs.

\* Reference National Glass Association (NGA) installation manual for more details.

For Technical Assistance in the United States and Canada 1.800.421.6144. Press 2, then option 1

C.R. Laurence Co., Inc. • 2503 E. Vernon Ave., Los Angeles, CA 90058 • 1.800.421.6144 • [crlaurence.com](http://crlaurence.com)

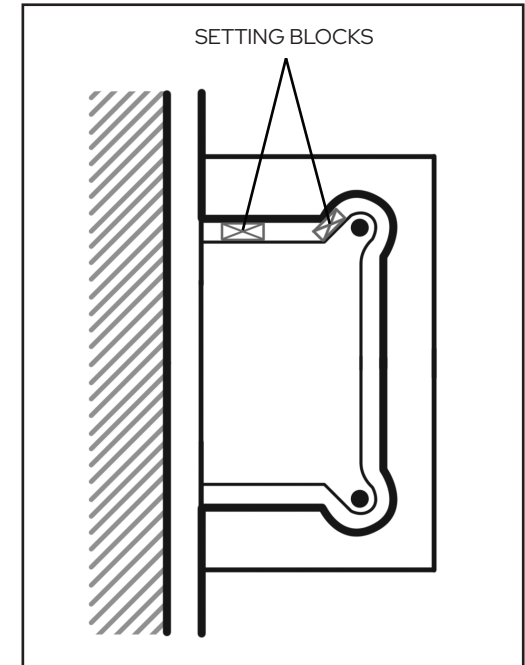

A wall mounted hinge door with setting block material between the body of the hinge and the glass cutout to block the glass into position.