

## MOUNTING INSTRUCTIONS

- DETERMINE HAND OF DOOR AND ESTABLISH CENTER LINE OF PADS ON STILES.
- PREPARE STILES PER TEMPLATES:  
10-484 TEMPLATE FOR ACTIVE STILE.  
10-475 TEMPLATE FOR INACTIVE STILE.
- DRILL CYLINDER MOUNTING HOLES ONLY IF REQUIRED
- LOCATE CENTER LINE OF CYLINDER ON EXTERIOR SIDE OF ACTIVE STILE AND DRILL IF REQUIRED.
- TRIM TAIL PIECE TO FIT AS SHOWN.
- MOUNT CYLINDER IN PLACE AND SECURE WITH MOUNTING SCREWS. (SCREWS MUST BE FLUSH WITH DOOR.)
- DETERMINE FUNCTION DESIRED:  
**A.) REGULAR FUNCTION KEY REMOVABLE IN EITHER LOCKED OR UNLOCKED POSITION. FULLY RELEASE LATCH THEN SET INDEX MARK ON COUPLING BOSS STRAIGHT UP.**  
**B.) NIGHT LATCH FUNCTION: KEY REMOVABLE IN LOCKED POSITION ONLY. PREFORM STEP 'A' THEN ROTATE' COUPLING BOSS 90° TOWARDS HINGE SIDE.**
- DRILL .203 (5.15) DIA. AND TAP 1/4-20 THD (4 PLCS.) ON ACTIVE & INACTIVE STILES & INSTALL FOUR (4) 1/4-20(M6-1.0) SHOULDER STUDS. MOUNT ACTIVE PAD TO STILE WITH THREE 1/4-20(M6-1.0)x1/2(12.7) SOC. SET SCREWS.
- LOCATE AND DRILL MOUNTING HOLES FOR ADJUSTABLE STRIKE. (CENTER ON LATCH)
- MOUNT AND SECURE STRIKE AS SHOWN.
- CHECK OPERATION TO ASSURE THAT ALL PARTS AND CYLINDER ARE FUNCTIONING PROPERLY. ADJUST AS REQUIRED.
- MOUNT INACTIVE PAD TO STILE WITH THREE (3) 1/4-20 (M6-1.0)x 1/2(12.7) SOC. SET SCREWS.
- CUT LENGTH OF PANIC BAR BY MEASURING FROM INSIDE TO INSIDE EDGE OF MOUNTING PADS. 1/32± (.79) FIT TO SIZE.
- LOOSEN INACTIVE PAD. INSTALL AND SECURE PANIC BAR WITH TWO 1/4-20(M6-1.0) x 1(25.4) OVAL HD.M.S. (PHIL.) RETIGHTEN PAD SET SCREWS.

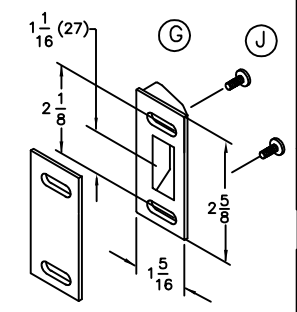

"C" STRIKE

### DOGGING INSTRUCTIONS:

**TO DOG-** DEPRESS CROSS BAR TURN KEY TOWARD HINGE SIDE OR PUSH DOGGING PIN UP AND TURN 90° EITHER DIRECTION.  
**TO UNDOG-** DEPRESS CROSS BAR TURN KEY TOWARD LOCK SIDE OR ROTATE DOGGING PIN UNTIL IT RELEASES.

FUNCTIONAL CYLINDERS	DIM.
ILCO	1/4(6.35)
LOCKWOOD	
YALE	
CORBIN	
SCHLAGE	
RUSSWIN	
WELCH	
KEIL	
SARGENT	

J 1.28.08 PAN HEAD WAS OVAL	ECN1999	RM
H 6.20.05 REVISE "DOGGING INSTRUCTIONS" HINGE WAS LOCK	ECN1846	RM
G 6.26.03 INCORPORATE CENTERED "C" STRIKE	ECN1625	RM
F 6/11/98 R E D R A W N	ECN1143	RM
DIMENSIONAL TOLERANCES UNLESS OTHERWISE SPECIFIED		APPROVALS DATE
DECIMAL DIMENSIONS .XXX ± .010	CHECKED	
DECIMAL DIMENSIONS .XXX ± .005	DRAWN	RM 6/28/97
ANGULAR ± X ° FRACTIONAL ± 1/64	SCALE	NONE
FILE NO.	MATERIAL	SCALE
NEXT ASSY. 1095-KITS	FINISH	INSTALLATION GUIDE 1095 RIM PANIC DEVICE FOR OFFSET PIVOT OR BUTT HINGE
QTY. USED 1	HEAT TREAT	SHEET 1 OF 1 SHEETS DWG. NO. 10-481 REV. J



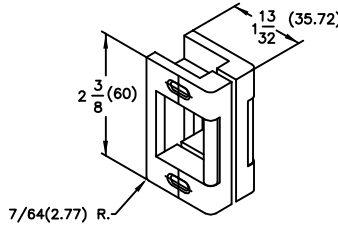
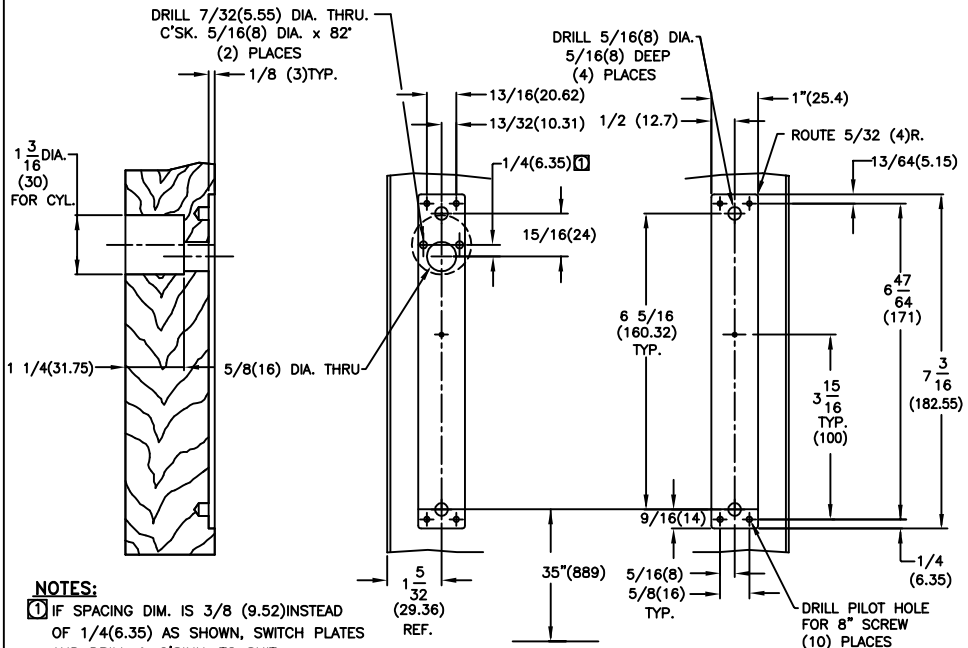
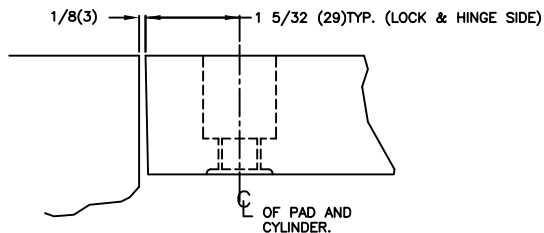

TYPE "P" ADJUSTABLE STRIKE

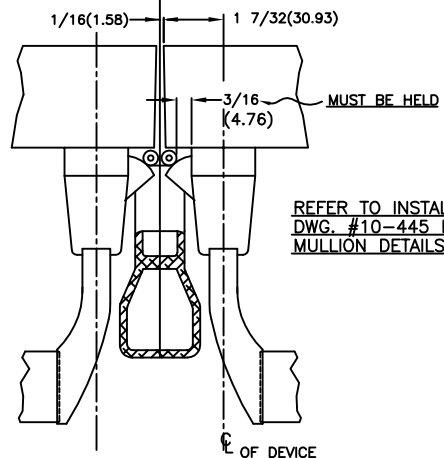

REFER TO INSTALLATION DWG. #10-445 FOR MULLION DETAILS.

**NOTES:**  
 ① IF SPACING DIM. IS 3/8 (9.52) INSTEAD OF 1/4(6.35) AS SHOWN, SWITCH PLATES AND DRILL & C'SINK. TO SUIT.

**ACTIVE SIDE ROUTING** FOR PLATE #30-886  
**INACTIVE SIDE ROUTING** FOR PLATE #30-884

PACKAGE NO. 30-894

**1095 WOOD APPLICATION**  
 ROUTING OF WOOD DOOR FOR SUPPORT PLATES

**L.H.R.B. SHOWN**  
**R.H.R.B. OPPOSITE**

FILE NO.	MATERIAL	SCALE	NONE	SHEET 1 OF 1 SHEETS
NEXT ASSY.	FINISH	1095 xWOOD APPLICATION	DWG. NO.	REV.
QTY. USED	HEAT TREAT		10-482	F

F 3/14/98 REDRAWN ECN1143

DIMENSIONAL TOLERANCES UNLESS OTHERWISE SPECIFIED	APPROVALS	DATE
DECIMAL DIMENSIONS .XXX ± .010	APPROVED	
DECIMAL DIMENSIONS .XXX ± .005	CHECKED	
ANGULAR ± °   FRACTIONAL ± 1/64	DRAWN	RM 7/7/97



### MOUNTING INSTRUCTIONS

1. DETERMINE HAND OF DOOR AND ESTABLISH CENTER LINE OF PADS ON STILES.
2. PREPARE STILES PER TEMPLATES:  
10-484 TEMPLATE FOR ACTIVE STILE.  
10-475 TEMPLATE FOR INACTIVE STILE.
3. DRILL CYLINDER MOUNTING HOLES ONLY IF REQUIRED
4. LOCATE CENTER LINE OF CYLINDER ON EXTERIOR SIDE OF ACTIVE STILE AND DRILL IF REQUIRED.
5. TRIM TAIL PIECE TO FIT AS SHOWN.
6. MOUNT CYLINDER IN PLACE AND SECURE WITH MOUNTING SCREWS. (*SCREWS MUST BE FLUSH WITH DOOR.*)
7. DETERMINE FUNCTION DESIRED:  
**A.) REGULAR FUNCTION KEY REMOVABLE IN EITHER LOCKED OR UNLOCKED POSITION. FULLY RELEASE LATCH THEN SET INDEX MARK ON COUPLING BOSS STRAIGHT UP.**  
**B.) NIGHT LATCH FUNCTION: KEY REMOVABLE IN LOCKED POSITION ONLY. PREFORM STEP 'A' THEN ROTATE COUPLING BOSS 90° TOWARDS HINGE SIDE.**

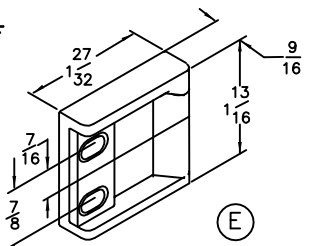

"S" STRIKE

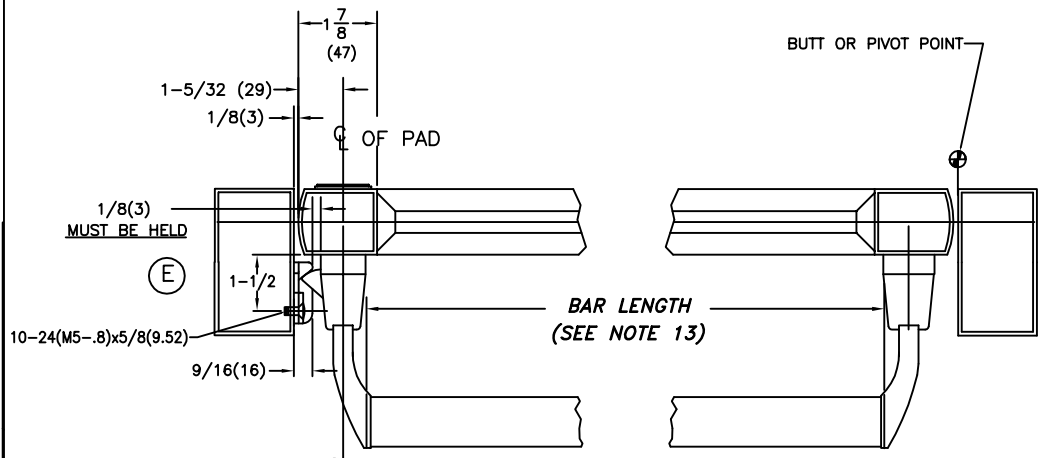

O.H.M.S. (2 PLCS.)

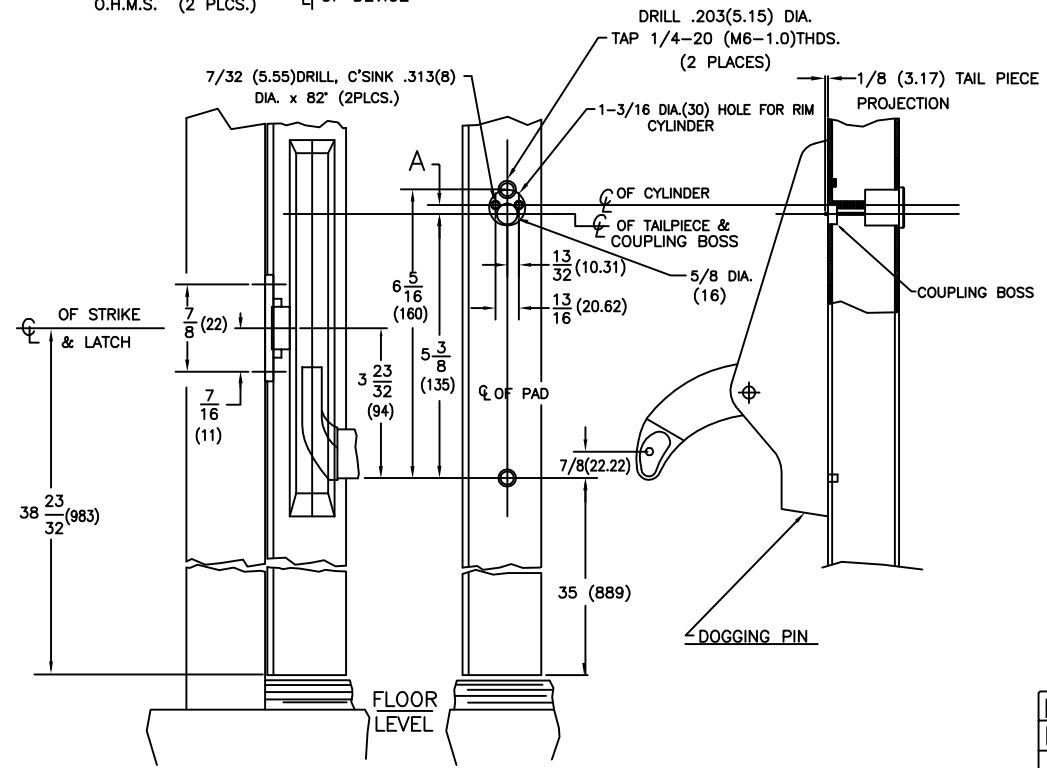

8. DRILL .203 (5.15)DIA. AND TAP 1/4-20 THD (4 PLCS.) ON ACTIVE & INACTIVE STILES & INSTALL FOUR (4) 1/4-20(M6-1.0) SHOULDER STUDS. MOUNT ACTIVE PAD TO STILE WITH THREE 1/4-20(M6-1.0)x1/2(12.7) SOC. SET SCREWS.
9. LOCATE AND DRILL MOUNTING HOLES FOR ADJUSTABLE STRIKE. (CENTER ON LATCH)
10. MOUNT AND SECURE STRIKE AS SHOWN.
11. CHECK OPERATION TO ASSURE THAT ALL PARTS AND CYLINDER ARE FUNCTIONING PROPERLY. ADJUST AS REQUIRED.
12. MOUNT INACTIVE PAD TO STILE WITH THREE (3) 1/4-20 (M6-1.0)x 1/2(12.7) SOC. SET SCREWS.
13. CUT LENGTH OF PANIC BAR BY MEASURING FROM INSIDE TO INSIDE EDGE OF MOUNTING PADS. 1/32± (.79) FIT TO SIZE.
14. LOOSEN INACTIVE PAD. INSTALL AND SECURE PANIC BAR WITH TWO 1/4-20(M6-1.0) x 1(25.4) OVAL HD.M.S. (PHIL.) RETIGHTEN PAD SET SCREWS.

**DOGGING INSTRUCTIONS:**

**TO DOG-** DEPRESS CROSS BAR TURN KEY TOWARD LOCK SIDE OR PUSH DOGGING PIN UP AND TURN 90° EITHER DIRECTION.  
**TO UNDOG-** DEPRESS CROSS BAR TURN KEY TOWARD LOCK SIDE OR ROTATE DOGGING PIN UNTIL IT RELEASES.

FUNCTIONAL CYLINDERS	DIM. A
ILCO	1/4(6.35)
LOCKWOOD	
YALE	
CORBIN	
SCHLAGE	
RUSSWIN	
WELCH	3/8(9.52)
KEIL	
SARGENT	

FILE NO.	MATERIAL
NEXT ASSY. 1095-KITS	FINISH
QTY. USED 1	HEAT TREAT

E 6.27.03 PICTORIAL SHOWING ROLLER-LESS "S" STRIKE SHOWN ECN1625		RM
D 6/11/98 R E D R A W N ECN1143		RM
DIMENSIONAL TOLERANCES UNLESS OTHERWISE SPECIFIED		APPROVALS DATE
DECIMAL DIMENSIONS .XX ± .010		APPROVED
DECIMAL DIMENSIONS .XXX ± .005		CHECKED
ANGULAR ± X ° FRACTIONAL ± 1/64		DRAWN RM 6/28/97
SCALE NONE		
INSTLLATION GUIDE 1095 RIM PANIC DEVICE FOR OFFSET PIVOT x "S" STRIKE		SHEET 1 OF 1 SHEETS
		DWG. NO. 10-499
		REV. E

