

Specifications:

- Material:** Solid brass
- Glass Thickness Range:** 5/16" (8mm) to 1/2" (12mm)
- Hole Size Required:** 7/8" (22mm)
- Includes:** Mounting screws and gaskets

GLASS CLAMPS

Adjustable Square Wall Mount Clamp
Cat No. ADJSQ037

Note: The ADJSQ037 Adjustable Square Wall-to-Glass Clamp is designed for use in fastening a fixed panel of glass that runs into a wall at an angle other than 90 degrees. It is important to note the clamp can be mounted to the wall on either the long-point side or short-point side of the miter, on angles up to 25 degrees from 90 degrees (not lower than 65 degrees or over 115 degrees - see Example 1 below). For angles more than 25 degrees from 90 degrees (lower than 65 degrees or over 115 degrees), the wall-mounted portion must be fastened on the side of the glass that has the short-point of the miter (see Example 2 below).

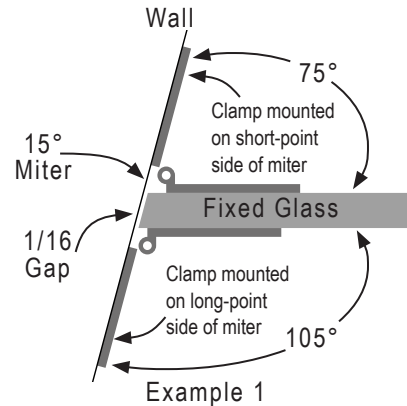

Example 1

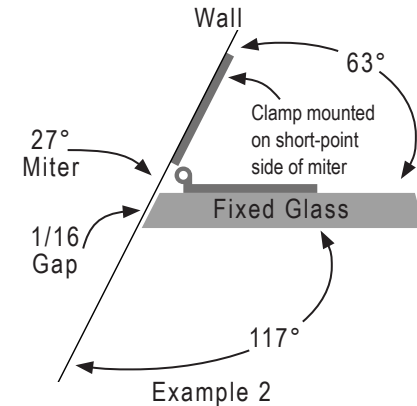

Example 2

Identifying Your Angle and Miter:

In order to use the ADJSQ037 the angle the glass runs into the wall must be properly identified. Please use the following as a guideline to correctly identify the angle and miter required:

When a fixed panel of glass runs into a wall squarely at 90 degrees, the angle/miter is considered "0". "0" means "no miter" on the glass, just a polished edge. If a glass panel runs into a wall at an angle, a miter should be put on the glass to correspond with the number of degrees from 90 (or "0" miter) the glass is to be mitered. In Example 1 above, the glass is running into the wall at 105°/75°. Each of these numbers is 15° from 90°. As shown in Example 1 above, a 15° miter is put on the glass. To get the correct hole location in the glass, use the chart to the right.

Hole Drilling Information

The table to the right addresses the dimension required from the long-point of the miter to the centerline of a 7/8" (22 mm) hole in the glass. **No U-notches are required for the ADJSQ037.** All dimensions shown already allow for a 1/16" (1.5 mm) clearance between the glass and the wall.

Angle	Dimension from long-point of miter to center of 7/8" (22mm) diameter holes	
	Mount to wall on short-point of miter	Mount to wall on long-point of miter
0° - 5°	1-1/2" (38 mm)	1-1/2" (38 mm)
6° - 10°	1-9/16" (40 mm)	1-7/16" (37 mm)
11° - 15°	1-5/8" (41 mm)	1-7/16" (37 mm)
16° - 20°	1-11/16" (43 mm)	1-3/8" (35 mm)
21° - 25°	1-3/4" (44 mm)	1-3/8" (35 mm)
26° - 30°	1-7/8" (48 mm)	N/A
31° - 35°	1-15/16" (49 mm)	N/A
36° - 40°	2-1/16" (52 mm)	N/A
41° - 45°	2-3/16" (56 mm)	N/A
46° - 47°	2-5/16" (59 mm)	N/A
48° - 50°	2-7/16" (62 mm)	N/A

Note: All dimensions above already provide for a 1/16" (1.5mm) clearance between the glass and the wall.