

CRL CIELO WINDSCREEN SYSTEM

- DESIGNED FOR 9/16" THK. LAMINATED TEMPERED GLASS
- 6'-0" TO 8'-0" STANDARD POST HEIGHTS
- DESIGNED FOR STEEL OR CONCRETE MOUNTING ATTACHMENT
- 4 1/2" X 3 1/4" STD. POSTS

STRUCTURAL DISCLAIMER:

ALL CUSTOMERS WHO IN ANY WAY UTILIZE THIS PRODUCT ARE SOLELY RESPONSIBLE TO CONSULT A STRUCTURAL ENGINEER TO DETERMINE THE SUITABILITY OF THE PRODUCT FOR THE INTENDED USE AND SITE CONDITIONS. ALL INSTALLERS MUST BE QUALIFIED AND HAVE PROFESSIONAL KNOWLEDGE ABOUT COMPLIANCE WITH LOCAL, STATE AND FEDERAL REGULATIONS, SAFETY FACTORS, AND THE APPROPRIATE CHOICE OF FIXING MATERIAL AND PROCEDURES.

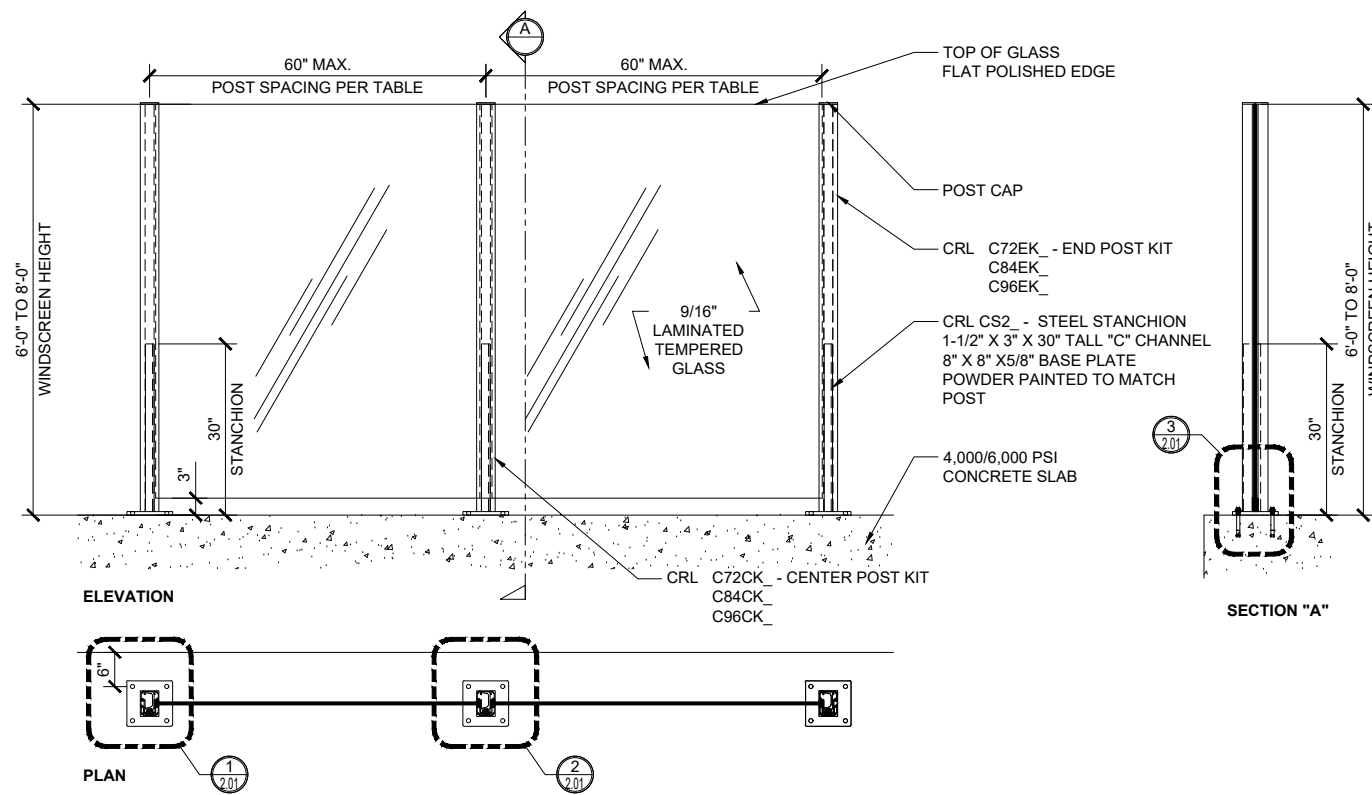

① TYP. WINDSCREEN (SURFACE MOUNT_CONCRETE)

SCALE: 3/4"=1'-0"

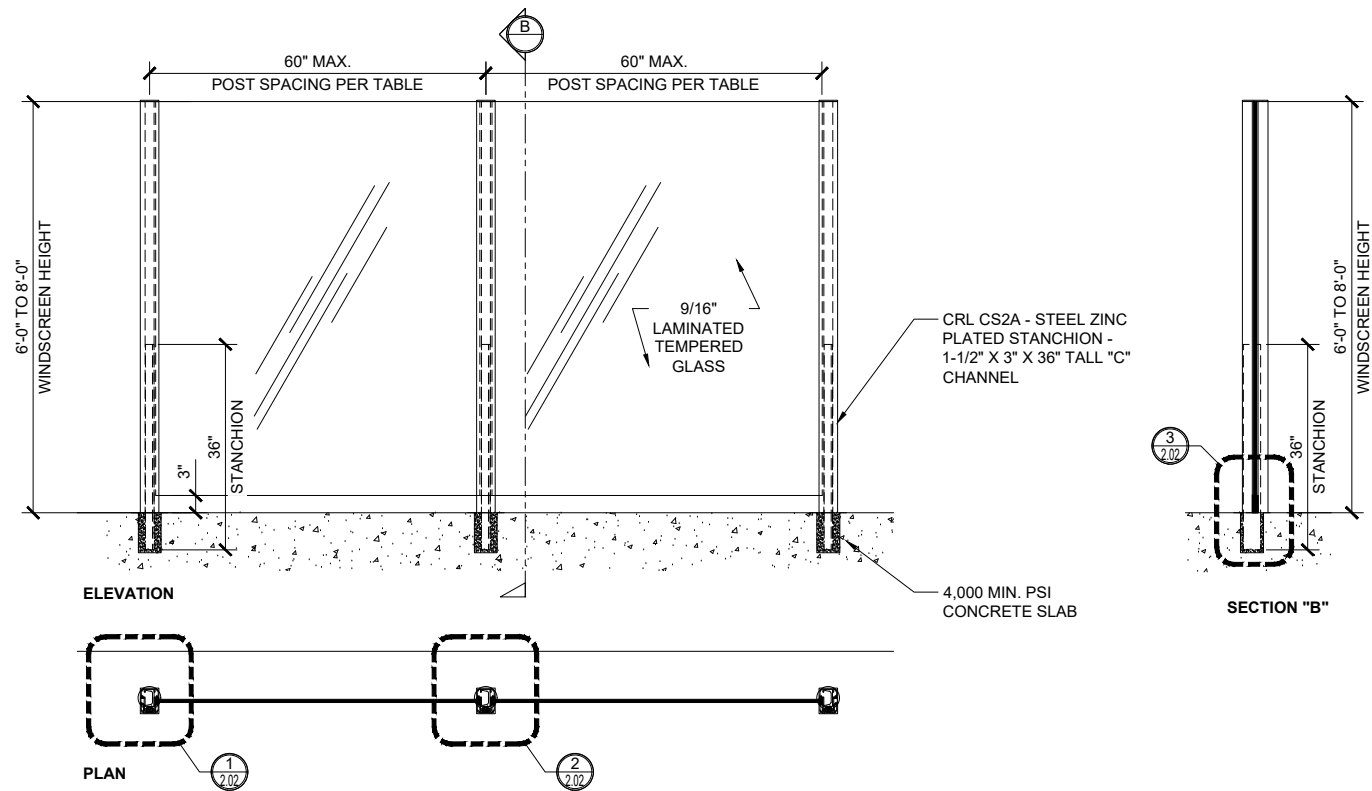

② TYP. WINDSCREEN (CORE MOUNT_CONCRETE)

ARCH REF: SCALE: 3/4"=1'-0"

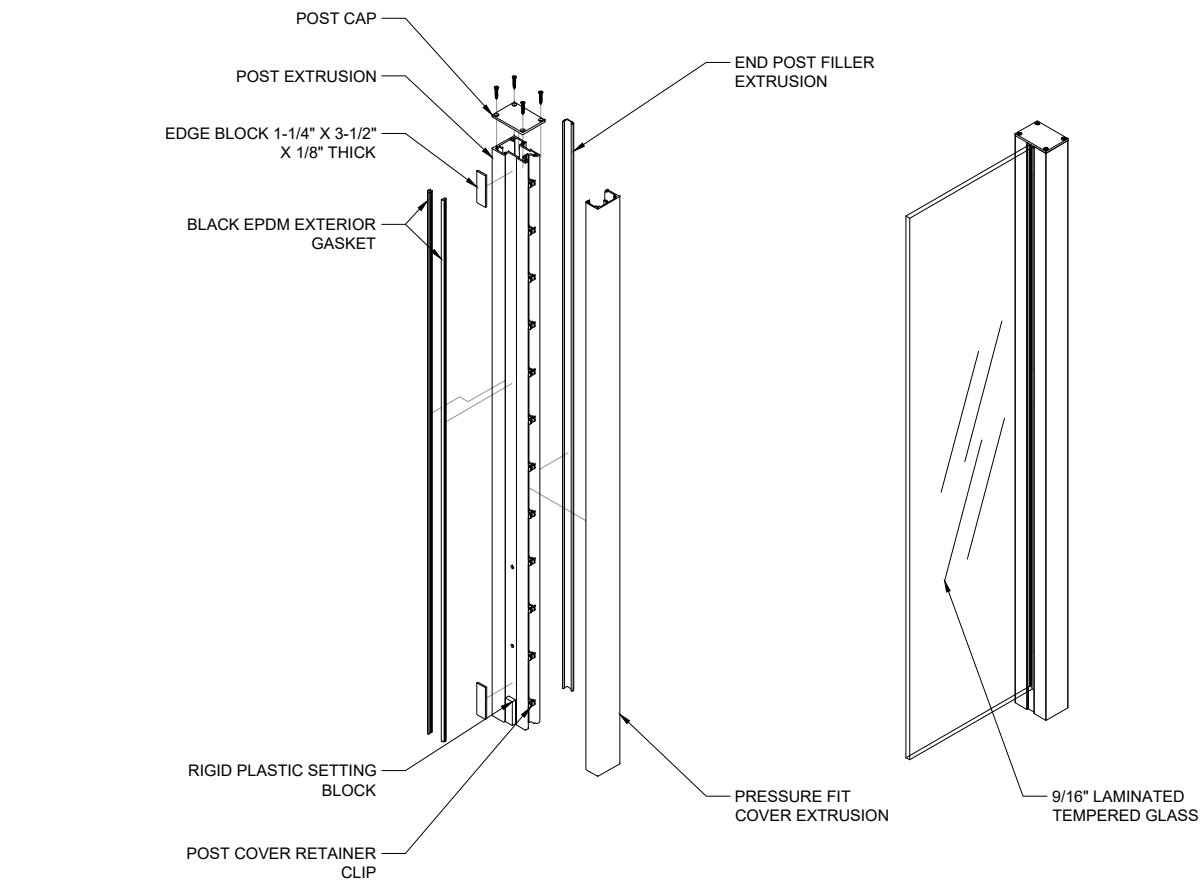

③ TYP. WINDSCREEN (SURFACE MOUNT_STEEL)

1" THK. BASE PLATE SCALE: 3/4"=1'-0"

NOTE:
SEE TABLES FOR MAX. WINDSCREEN
DIMENSIONS AND WIND LOADS



2503 E. Vernon Avenue, Los Angeles, CA 90058-1887
PH (800)-421-6144 FX 800-587-7501 www.crlaerance.com

Description:
CRL CIELO
WINDSCREEN SYSTEM

FOR 9/16" GLASS

Drawn By: AB

Date: 05/05/2021

Scale: AS NOTED

File Name:

YS0129A_CIELO SYSTEM DRAWINGS

Sheet

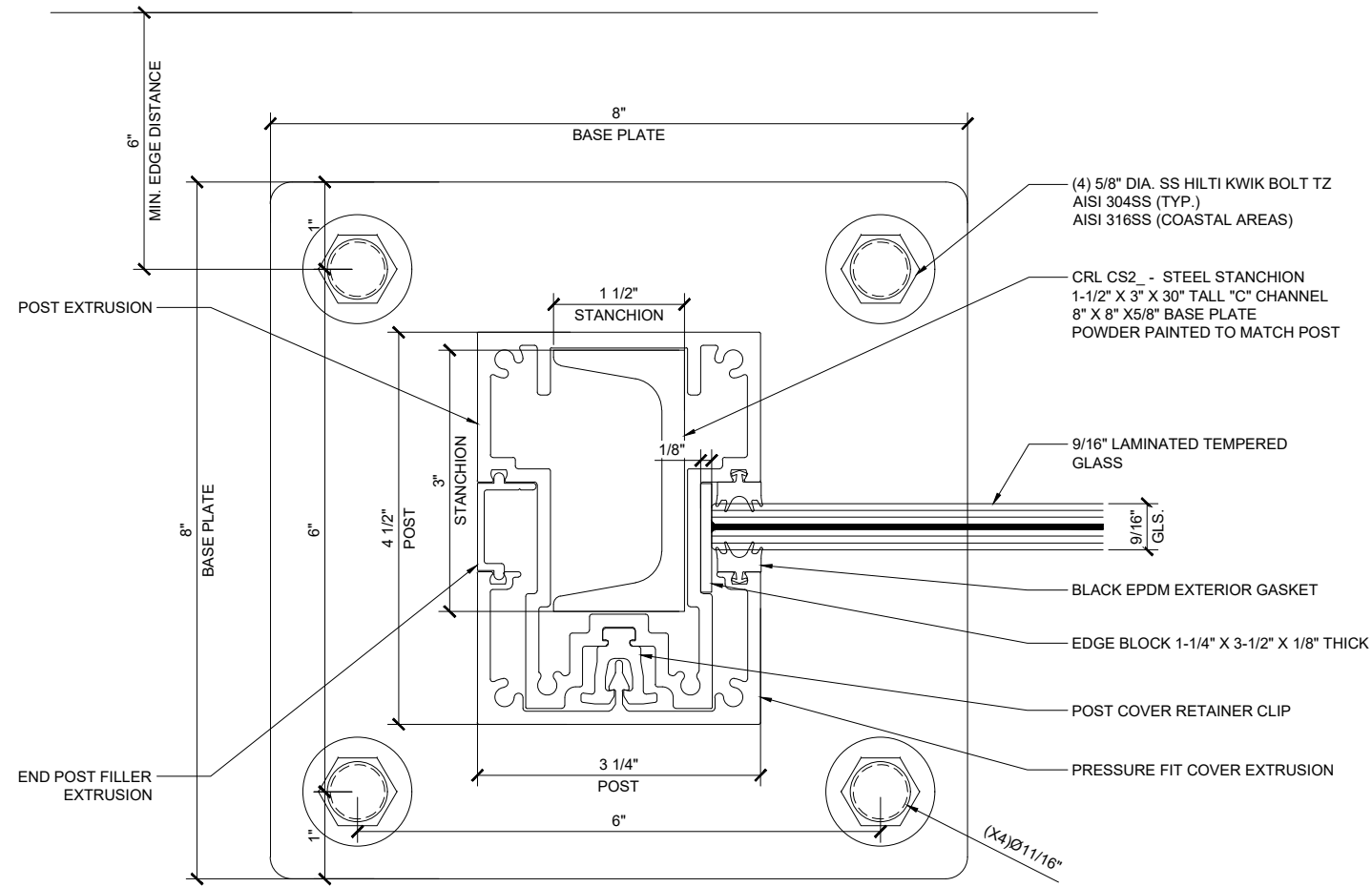

1 WINDSCREEN END POST DETAIL

ARCH REF: SCALE: 1'-0"=1'-0"

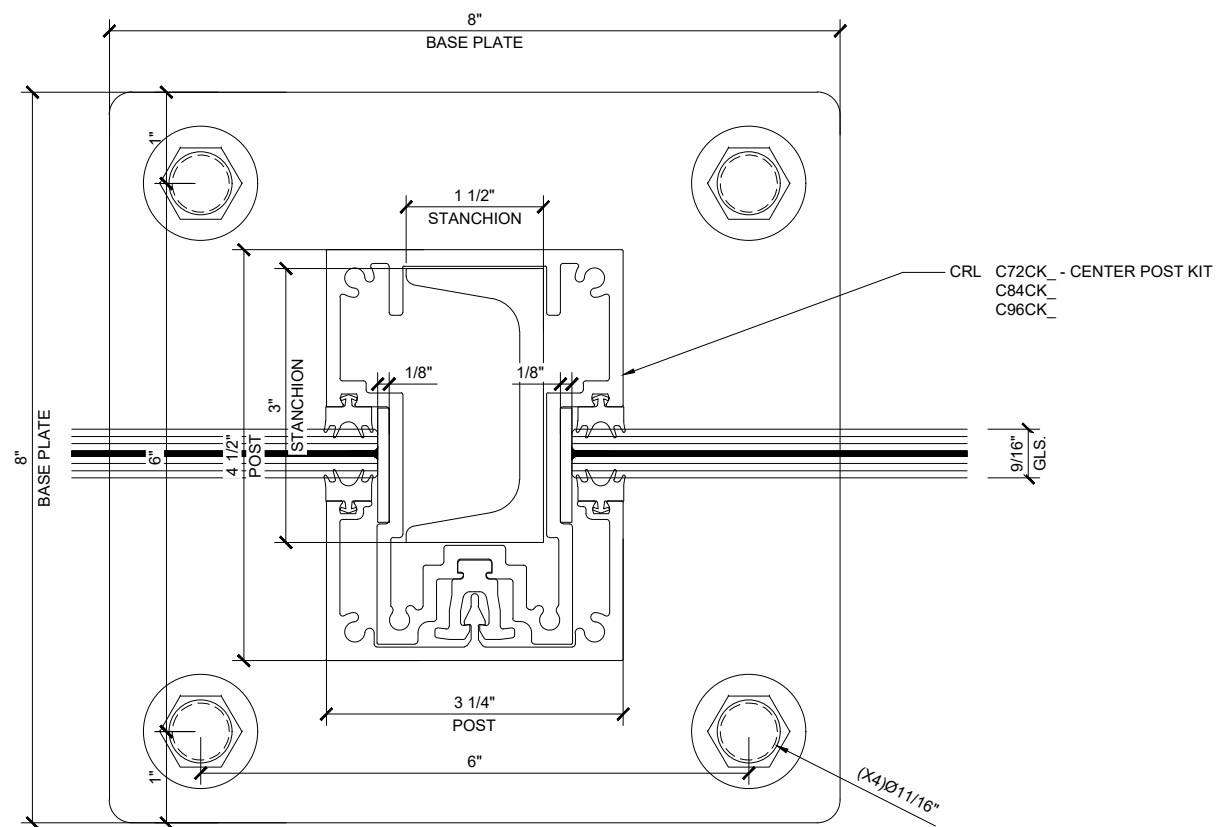

2 WINDSCREEN CENTER POST DETAIL

ARCH REF: SCALE: 1'-0"=1'-0"

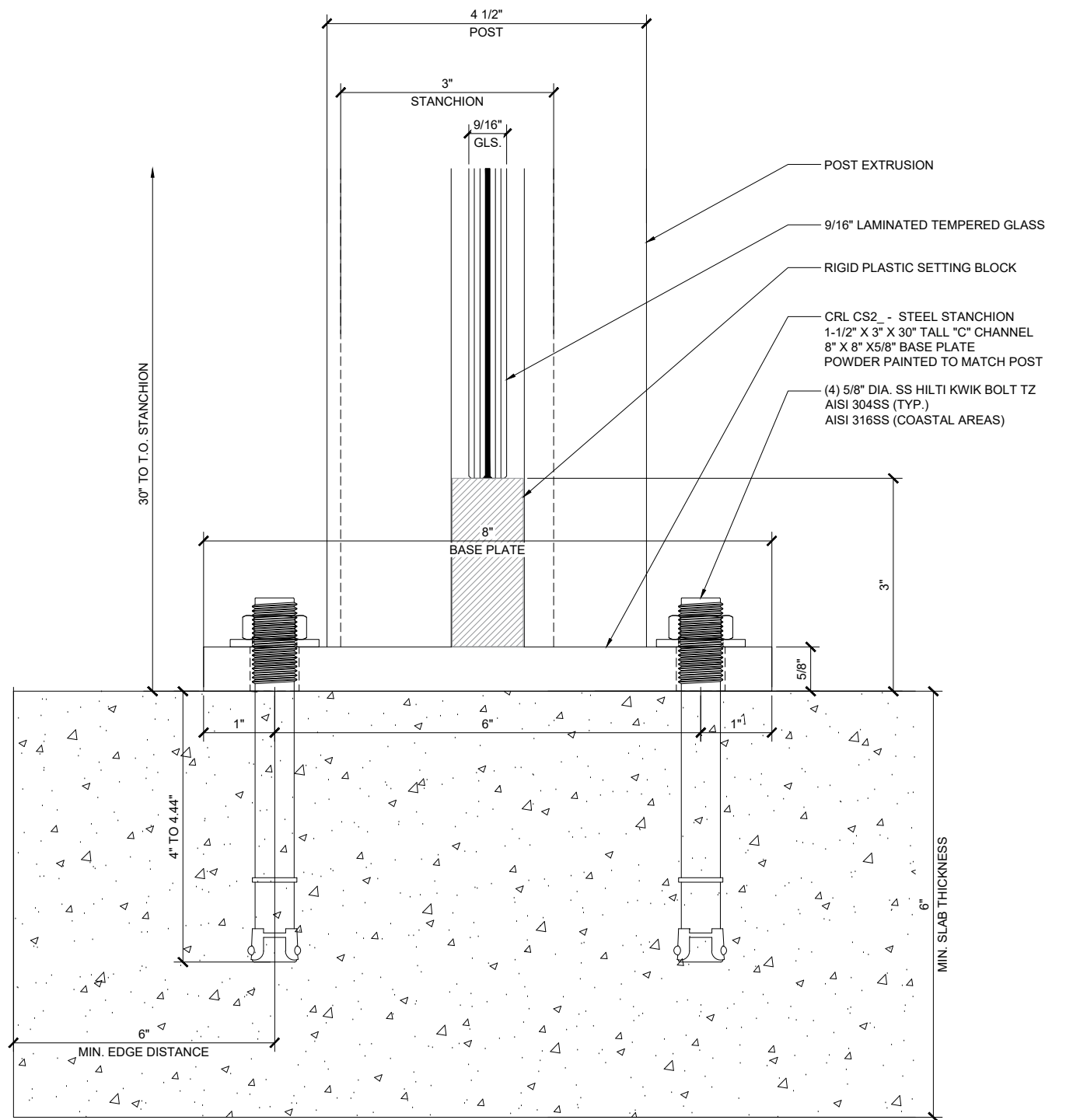

3 WINDSCREEN ANCHOR DETAIL

ARCH REF: SCALE: 1'-0"=1'-0"



Description:
CRL CIELO
WINDSCREEN SYSTEM

FOR 9/16" GLASS

Drawn By: AB
Date: 05/05/2021
Scale: AS NOTED
File Name:
SYS0129A_CIELO SYSTEM DRAWINGS
Sheet

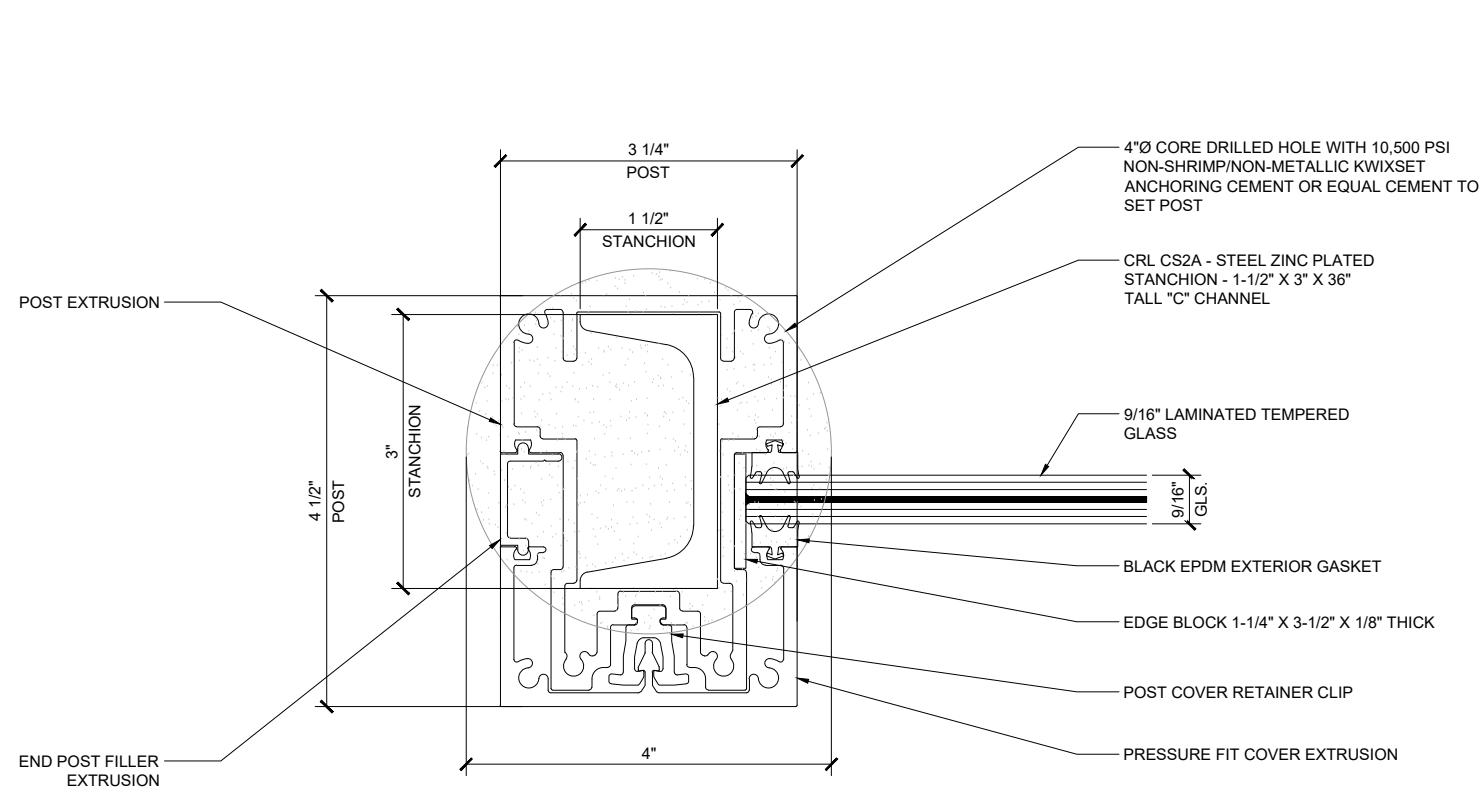

1 WINDSCREEN END POST DETAIL
 ARCH REF: _____ SCALE: 1'-0"=1'-0"

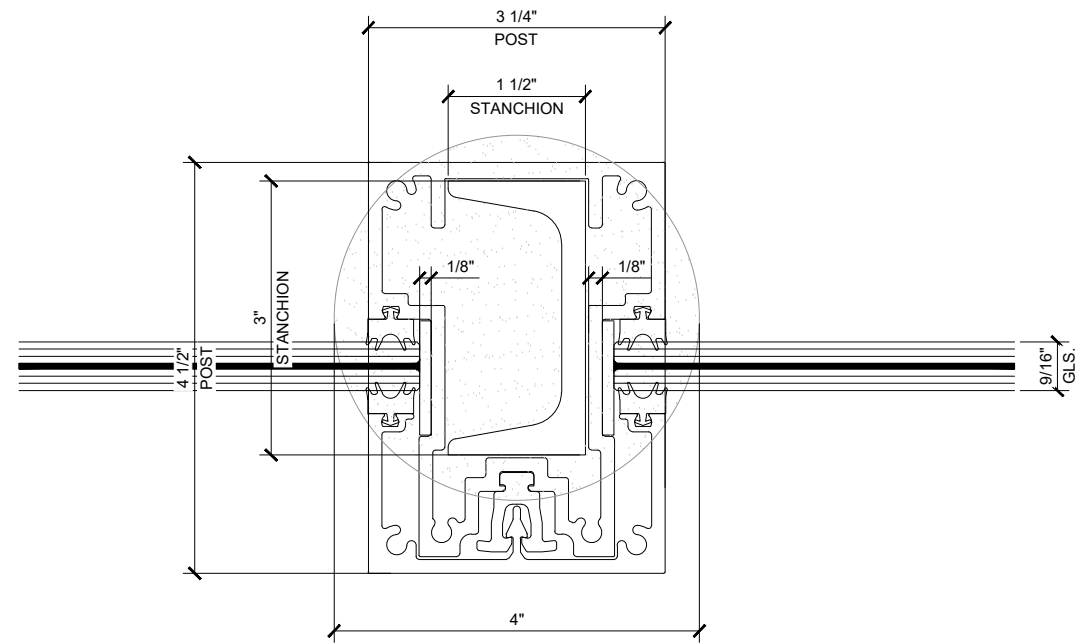

2 WINDSCREEN CENTER POST DETAIL
 ARCH REF: _____ SCALE: 1'-0"=1'-0"

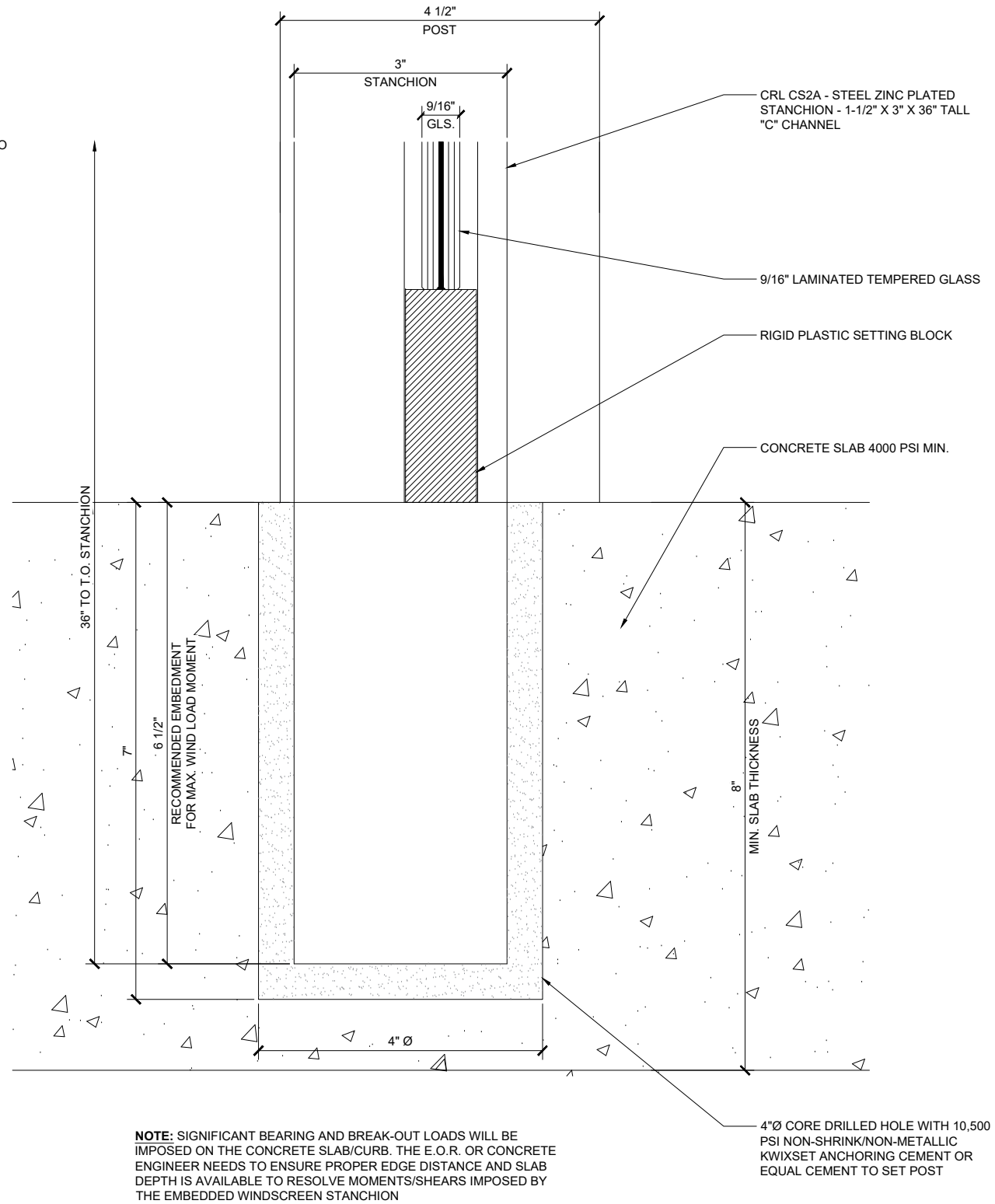

3 WINDSCREEN ANCHOR DETAIL
 ARCH REF: _____ SCALE: 1'-0"=1'-0"



Description:
 CRL CIELO
 WINDSCREEN SYSTEM

 FOR 9/16" GLASS

Drawn By: AB
 Date: 05/05/2021
 Scale: AS NOTED
 File Name:
 SYS0129A_CIELO SYSTEM DRAWINGS
 Sheet

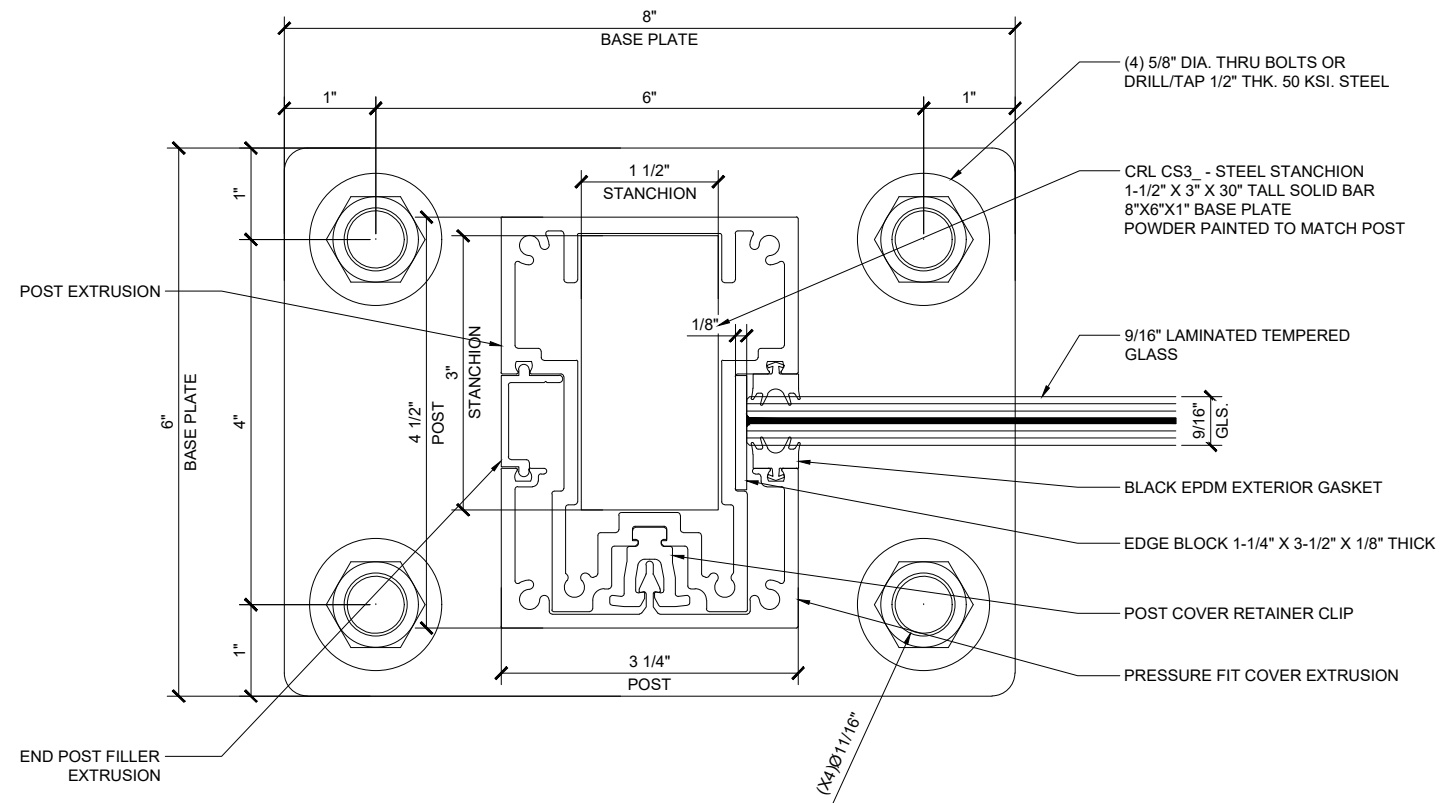

1 WINDSCREEN END POST DETAIL
 ARCH REF: _____ SCALE: 1'-0"=1'-0"

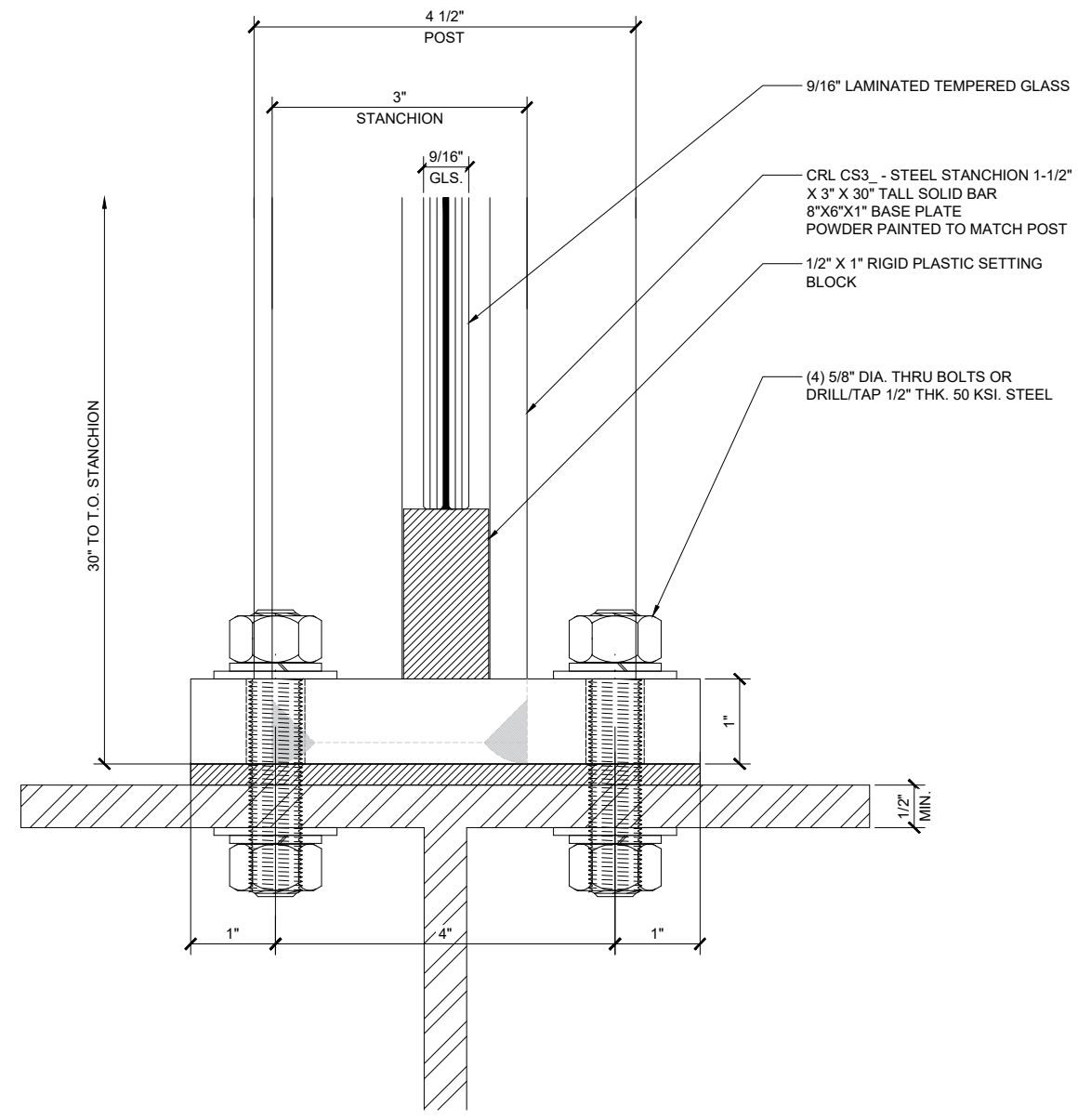

3 WINDSCREEN ANCHOR DETAIL
 ARCH REF: _____ SCALE: 1'-0"=1'-0"

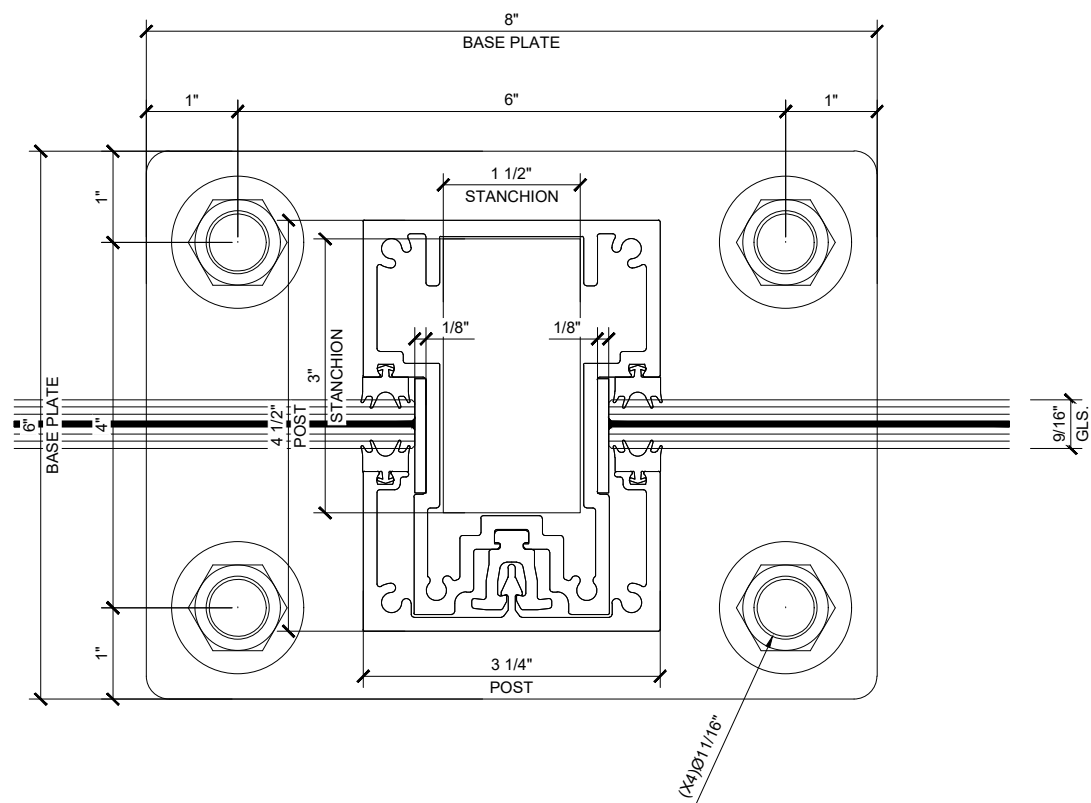

2 WINDSCREEN CENTER POST DETAIL
 ARCH REF: _____ SCALE: 1'-0"=1'-0"



Description:
 CRL CIELO
 WINDSCREEN SYSTEM

 FOR 9/16" GLASS

Drawn By: AB
 Date: 05/05/2021
 Scale: AS NOTED
 File Name:
 SYS0129A_CIELO SYSTEM DRAWINGS
 Sheet