

FRONT VIEW

Specifications:

Material: Solid brass
Glass Thickness Range: 3/8"(10mm) to 1/2"(12mm)
Hole Size Required: 5/8"(16mm) or 3/4"(19mm)
Includes: Mounting screws and gaskets

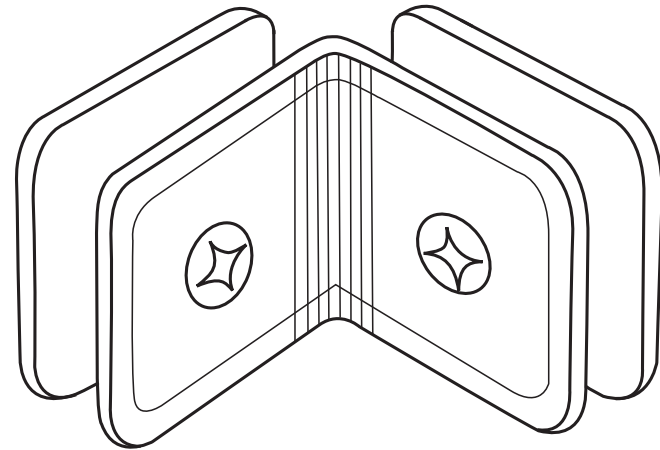

REAR VIEW

GLASS CLAMPS

Estate 90° Glass Clamp
CAT. NO. EST111

***NOTE:** Do not exceed either maximum weight or width when choosing proper quantity of hinges.

Template Shown on Next Page

IMPORTANT: Project measurements from the edge of the glass.

TYPICAL INSTALLATION

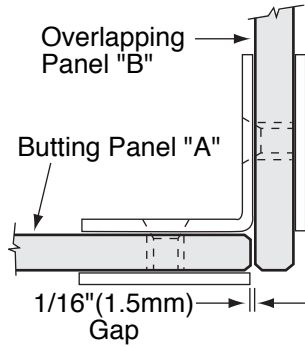

TEMPLATE OPTION FOR SQUARE CUT GLASS

Butting Panel

5/8" (16mm) or 3/4" (19mm) Diameter Hole

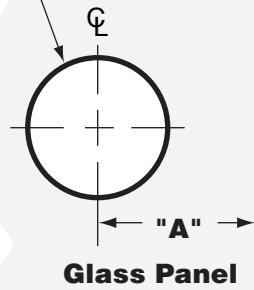

Overlapping Panel

5/8" (16mm) or 3/4" (19mm) Diameter Hole

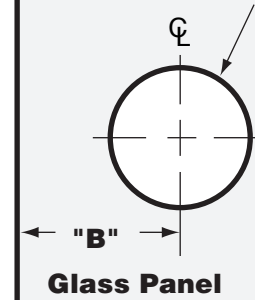

Glass Thickness	"A" Measurement	"B" Measurement
3/8"	1-1/8" (29mm)	1-1/2" (38mm)
1/2"	1-1/8" (29mm)	1-5/8" (41mm)

TYPICAL INSTALLATION

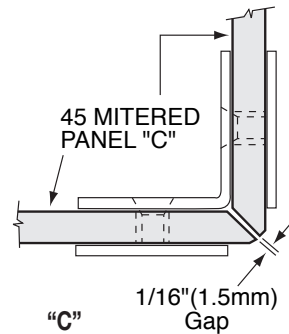

Glass Thickness	"C" Measurement
3/8"	1-7/16" (37mm)*
1/2"	1-9/16" (40mm)*

*From the Outside Edge of Miter

TEMPLATE OPTION FOR 45° MITERED GLASS

45° Mitered Panel

5/8" (16mm) or 3/4" (19mm) Diameter Hole

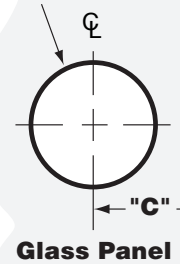

45° Mitered Panel

5/8" (16mm) or 3/4" (19mm) Diameter Hole

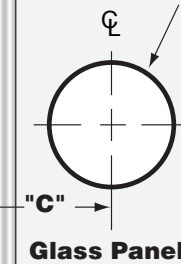

Outside Edge of Miter

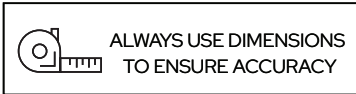

GLASS CLAMPS

The Template Options on This Page Apply to the Following Clamps: 90° Glass Clamp CAT. NO. EST111