

## Cutting Formula for Frameless Double KD Slider

This information applies to Cat. No.'s S386060, S386072, S146060, S146072

(Installation instructions are shown in Section 3)

### Components Description

HEADER  
 TOP RAIL  
 SIDE JAMB  
 BOTTOM TRACK

Custom sizes and configurations are available by special order. Please fax your drawing to (800) 587-7501 or call (800) 421-6144 Extension 777

### Metal Size Cutting Formula

HEADER TOP MEASUREMENT LESS 1/16" (1.5mm)  
 TOP RAIL OVERALL WIDTH DIVIDED BY 2, PLUS 3/16" (5mm)  
 SIDE JAMB OVERALL HEIGHT LESS 1-5/8" (41mm)  
 BOTTOM TRACK BOTTOM MEASUREMENT LESS 3/4" (19mm)

**Note: Cut 3/8" (10mm) from each end.**

### Glass Size Cutting Formula

WIDTH = OVERALL WIDTH DIVIDED BY 2, PLUS 1/4" (6mm)  
 HEIGHT FOR INSIDE PANEL = OVERALL HEIGHT LESS 2-3/8" (60mm)  
 HEIGHT FOR OUTSIDE PANEL = OVERALL HEIGHT LESS 2-1/2" (64mm)

### All Stock 3/8" (10mm) and 1/4" (6mm) Frameless Sliders

come with a Knob and a 24" (610mm) Towel Bar

All Towel Bars and Knobs require 1/2" (12mm) diameter holes.

The placement of the holes for the Towel Bar are to be centered on the glass.

The holes for the Towel Bar are to be 24" (610mm) center-to-center.\*

The hole placement for the knob is centered on the vertical edge and should match the distance in from the edge with the Towel Bar glass.

\*Call for size of Towel Bar provided with custom units.

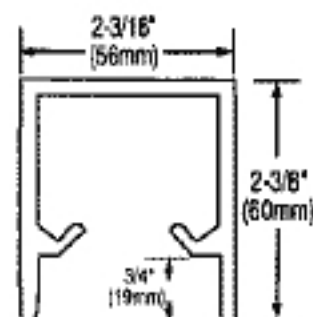

Header for 3/8" (10mm) Glass

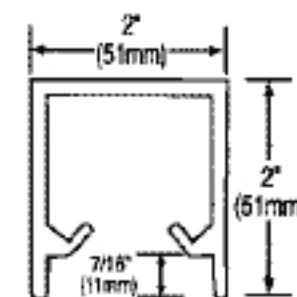

Header for 1/4" (6mm) Glass

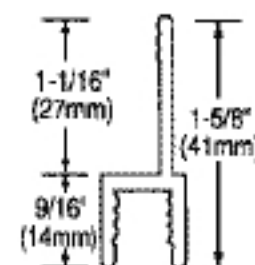

Top Rail for 3/8" (10mm) Glass

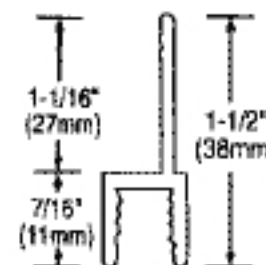

Top Rail for 1/4" (6mm) Glass

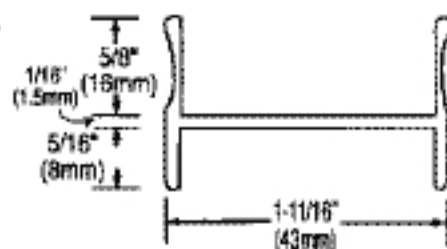

Side Jamb for 3/8" (10mm) or 1/4" (6mm) Glass

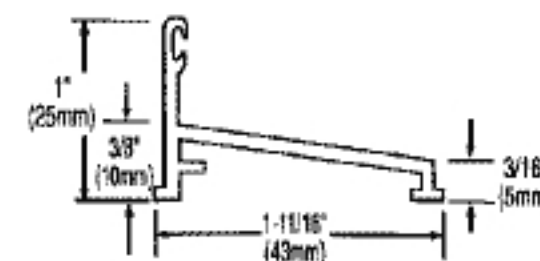

Bottom Track for 3/8" (10mm) or 1/4" (6mm) Glass