

ICC Evaluation Service, Inc.
www.icc-es.org

Business/Regional Office ■ 5360 Workman Mill Road, Whittier, California 90601 ■ (562) 699-0543
Regional Office ■ 900 Montclair Road, Suite A, Birmingham, Alabama 35213 ■ (205) 599-9800
Regional Office ■ 4051 West Flossmoor Road, Country Club Hills, Illinois 60478 ■ (708) 799-2300

DIVISION: 03—CONCRETE
Section: 03151—Concrete Anchoring

REPORT HOLDER:

POWERS FASTENERS, INC.
2 POWERS LANE
BREWSTER, NEW YORK 10509
(914) 235-6300 or (800) 524-3244
www.powers.com
engineering@powers.com

EVALUATION SUBJECT:

**POWERS WEDGE-BOLT®+ SCREW ANCHORS IN
 CRACKED AND UNCRACKED CONCRETE**

1.0 EVALUATION SCOPE

Compliance with the following codes:

- 2006 *International Building Code*® (2006 IBC)
- 2006 *International Residential Code*® (2006 IRC)
- 2003 *International Building Code*® (2003 IBC)
- 2003 *International Residential Code*® (2003 IRC)
- 1997 *Uniform Building Code*™ (UBC)

Property evaluated:

Structural

2.0 USES

The Powers Wedge-Bolt®+ screw anchors are used to resist static, wind and seismic tension and shear loads in cracked and uncracked normal-weight concrete and structural sand-lightweight concrete having a specified compressive strength, f'_c , of 2,500 psi to 8,500 psi (17.2 MPa to 58.6 MPa); and cracked and uncracked normal-weight or structural sand-lightweight concrete over steel deck having a minimum specified compressive strength, f'_c , of 3,000 psi (20.7 MPa). The 1/4-inch-diameter (6.4 mm) anchor is limited to uncracked concrete. The anchoring system is available in 1/4-inch, 3/8-inch, 1/2-inch, 5/8-inch and 3/4-inch (6.4mm, 9.5 mm, 12.7 mm, 15.9 mm and 19.1 mm) diameters and is an alternative to cast-in-place anchors described in Sections 1911 and 1912 of the 2006 IBC, Sections 1912 and 1913 of the 2003 IBC and Sections 1923.1 and 1923.2 of the UBC. The anchors may also be used where an engineered design is submitted in accordance with Section R301.1.3 of the 2006 and 2003 IRC.

3.0 DESCRIPTION

3.1 General:

Wedge-Bolt+ screw anchors are comprised of an anchor body with hex washer head. The anchor body and hex washer head are manufactured from low-carbon steel which is case hardened and have minimum 0.0002-inch (5 µm) zinc plating in accordance with ASTM B 633. The Powers Wedge-Bolt+ screw anchor is illustrated in Figure 2.

The hex head of the anchor is formed with an integral washer and serrations on the underside. The anchor body is formed with dual lead threads and a chamfered tip. The anchors are installed in a predrilled hole with a powered impact wrench. The threads on the anchor tap into the sides of the predrilled hole and interlock with the base material during installation.

3.2 Concrete:

Normal-weight and structural sand-lightweight concrete must conform to Sections 1903 and 1905 of the IBC, as applicable.

3.3 Steel Deck Panels:

Steel deck panels must comply with the requirements of ASTM A 653 and have a minimum base-metal thickness of 0.035 inch (0.89 mm) (No. 20 gage).

4.0 DESIGN AND INSTALLATION

4.1 Strength Design:

4.1.1 General: Design strengths must be determined in accordance with ACI 318-05 Appendix D (2006 IBC) and this report. Design parameters are provided in Table 2 and Table 3 of this report. The anchor design must satisfy the requirements in ACI 318 Sections D.4.1.1 and D.4.1.2. The value of f'_c used in the calculation must be limited to a maximum of 8,000 psi (55.2 MPa), in accordance with ACI318 Section D.3.5. Strength reduction factors, ϕ , as given in ACI 318 Section D.4.4, and noted in Tables 2 and 3 of this report, must be used for load combinations calculated in accordance with Section 1605.2.1 of the IBC, Section 9.2 of ACI 318, or Section 1612.2.1 of the UBC. Strength reduction factors, ϕ , described in ACI 318 Section D.4.5 must be used for load combinations calculated in accordance with Appendix C of ACI 318 or Section 1909.2 of the UBC. Strength reduction factors, ϕ , corresponding to brittle steel elements must be used. An example calculation is provided in Figure 5.

4.1.2 Requirements for Static Steel Strength in Tension, N_{sa} : The nominal static steel strength of a single anchor in tension calculated in accordance with ACI 318, Section D.5.1.2, N_{sa} , is given in Table 2 of this report.

4.1.3 Requirements for Static Concrete Breakout Strength in Tension, N_{cb} or N_{cbg} : The nominal concrete breakout strength of a single anchor or a group of anchors in tension, N_{cb} or N_{cbg} , must be calculated in accordance with ACI 318 Section D.5.2, with modifications as described in this section. The basic concrete breakout strength of a single anchor in tension, N_b , must be calculated according to ACI 318 Section D.5.2.2, using the values of h_{ef} and k_{cr} as given in Table 2. The nominal concrete breakout strength in tension in regions where analysis indicates no cracking in accordance with ACI 318 Section D.5.2.6 must be calculated with the value of k_{uncr} as given in Table 2 and with $\psi_{cN} = 1.0$. The value $\psi_{cN} = 1.41$ describes the ratio of k_{uncr}/k_{cr} and must be disregarded in ACI 318 Section D.5.2.6 (Equation D-4 and Equation D-5).

For anchors installed in the soffit of structural sand-lightweight or normal-weight concrete filled steel deck floor and roof assemblies, as shown in Figure 4, calculation of the concrete breakout strength in accordance with ACI 318 Section D.5.2 is not required (see Section 4.1.5).

4.1.4 Requirements for Critical Edge Distance, c_{ac} : In applications where $c < c_{ac}$ and supplemental reinforcement to control splitting of the concrete is not present, the concrete breakout strength in tension for uncracked concrete, calculated according to ACI 318 Section D.5.2, must be further multiplied by the factor $\psi_{cp,N}$ given by Eq-1:

$$\psi_{cp,N} = \frac{c}{c_{ac}} \quad (\text{Eq-1})$$

whereby the factor $\psi_{cp,N}$ need not be taken less than $\frac{1.5h_{ef}}{c_{ac}}$.

For all other cases, $\psi_{cp,N} = 1.0$. In lieu of using ACI 318 Section D.8.6, values of c_{ac} provided in Table 2 of this report must be used.

4.1.5 Requirements for Static Pullout Strength in Tension, N_{pn} : The nominal pullout strength of a single anchor or a group of anchors, in accordance with ACI 318 Section D.5.3 in cracked and uncracked concrete, $N_{p,cr}$ and $N_{p,uncr}$, respectively, is given in Table 2. In accordance with ACI 318 Section D.5.3.2, the nominal pullout strength in cracked concrete can be adjusted by calculation according to Eq-2:

$$N_{pn,fc} = N_{p,cr} \left(\frac{f'c}{2,500} \right)^{0.5} \text{ (lb, psi)} \quad (\text{Eq-2})$$

$$N_{pn,fc} = N_{p,cr} \left(\frac{f'c}{17.2} \right)^{0.5} \text{ (N, MPa)}$$

In regions where analysis indicates no cracking in accordance with ACI 318 Section D.5.3.6, the nominal pullout strength in tension can be adjusted by calculation according to Eq-3:

$$N_{pn,fc} = N_{p,uncr} \left(\frac{f'c}{2,500} \right)^{0.5} \text{ (lb, psi)} \quad (\text{Eq-3})$$

$$N_{pn,fc} = N_{p,uncr} \left(\frac{f'c}{17.2} \right)^{0.5} \text{ (N, MPa)}$$

Where values for $N_{p,cr}$ or $N_{p,uncr}$ are not provided in Table 2, the pullout strength in tension need not be evaluated.

The nominal pullout strength in tension of the anchors installed in the upper and lower flute soffit of structural sand-lightweight or normal-weight concrete filled steel deck floor and roof assemblies, as shown in Figure 4, is provided in Table 2. In accordance with ACI 318 Section

D.5.3.2, the nominal pullout strength in cracked concrete must be calculated according to Eq-2, whereby the value of $N_{p,deck,cr}$ must be substituted for $N_{p,cr}$ and the value of 3,000 psi (20.7 MPa) must be substituted for the value of 2,500 psi (17.2 MPa) in the denominator. In regions where analysis indicates no cracking in accordance with ACI 318 Section 5.3.6, the nominal strength in uncracked concrete must be calculated according to Eq-3, whereby the value of $N_{p,deck,uncr}$ must be substituted for $N_{p,uncr}$ and the value of 3,000 psi (20.7 MPa) must be substituted for the value of 2,500 psi (17.2 MPa) in the denominator.

4.1.6 Requirements for Static Steel Shear Capacity, V_{sa} : The nominal steel strength in shear, V_{sa} , of a single anchor in accordance with ACI 318 Section D.6.1.2 is given in Table 3 of this report. The nominal shear strength of $V_{sa,deck}$ of anchors installed in the soffit of sand-lightweight or normal-weight concrete filled steel deck floor and roof assemblies, as shown in Figure 4, is given in Table 3.

4.1.7 Requirements for Static Concrete Breakout Strength in Shear, V_{cb} or V_{cbg} : The nominal concrete breakout strength of a single anchor or group of anchors in shear, V_{cb} or V_{cbg} , must be calculated in accordance with ACI 318 Section D.6.2, with modifications as described in this section. The basic concrete breakout strength of a single anchor in shear, V_b , must be calculated in accordance with ACI 318 Section D.6.2.2 using the value of l_e and d_o given in Table 3.

For anchors installed in the soffit of structural sand-lightweight or normal-weight concrete filled steel deck floor and roof assemblies, as shown in Figure 4, calculation of the concrete breakout strength in accordance with ACI 318 Section D.6.2 is not required (see Section 4.1.6).

4.1.8 Requirements for Static Concrete Pryout Strength in Shear, V_{cp} or V_{cpq} : The nominal concrete pryout strength of a single anchor or group of anchors, V_{cp} or V_{cpq} , must be calculated in accordance with ACI 318 Section D.6.3, modified by using the value of k_{cp} provided in Table 3 and the value of N_{cb} or N_{cbq} as calculated in Section 4.1.3 of this report.

For anchors installed in the soffit of structural sand-lightweight or normal-weight concrete filled steel deck floor and roof assemblies, as shown in Figure 4, calculation of the concrete pryout strength in accordance with ACI 318 Section D.6.3 is not required (see Section 4.1.6).

4.1.9 Requirements for Interaction of Tensile and Shear Forces: The effects of combined tensile and shear forces must be determined in accordance with ACI 318, Section D.7.

4.1.10 Requirements for Minimum Member Thickness, Minimum Anchor Spacing and Minimum Edge Distance: In lieu of ACI 318 Section D.8.3, values of c_{min} and s_{min} as given in Table 1 of this report must be used. In lieu of ACI 318 Section D.8.5, minimum member thicknesses, h_{min} , as given in Table 1 of this report must be used.

For anchors installed through the soffit of steel deck assemblies, the anchors must be installed in accordance with Figure 4 and shall have an axial spacing along the flute equal to the greater of $3h_{ef}$ or 1.5 times the flute width.

4.1.11 Requirements for Seismic Design:

4.1.11.1 General: For load combinations including seismic, the design must be performed according to ACI 318 Section D.3.3, as modified by Section 1908.1.16 of the 2006 IBC or the following:

CODE	ACI 318 SECTION D.3.3 SEISMIC REGION	CODE EQUIVALENT DESIGNATION
2003 IBC and 2003 IRC	Moderate or high seismic risk	Seismic Design Categories C, D, E and F
1997 UBC	Moderate or high seismic risk	Seismic Zones 2B, 3 and 4

The nominal steel strength and nominal concrete breakout strength for anchors in tension, and the nominal concrete breakout strength and pryout strength for anchors in shear, must be calculated according to ACI 318 Sections D.5 and D.6, respectively, taking into account the corresponding values in Table 2 and Table 3 of this report. The anchors comply with ACI 318 Section D.1 as brittle steel elements and must be designed in accordance with ACI 318 Section D.3.3.5.

4.1.11.2 Seismic Tension: The nominal steel strength and nominal concrete breakout strength for anchors in tension must be calculated according to ACI 318 Section D.5.1 and D.5.2, as described in Sections 4.1.2 and 4.1.3 of this report; and, in accordance with ACI 318 Section D.5.3.2, the appropriate value for nominal pullout strength in tension for seismic loads, N_{eq} or $N_{p,deck,cr}$ described in Table 2 of this report, must be used in lieu of N_{pn} .

4.1.11.3 Seismic Shear: The nominal concrete breakout strength and pryout strength for anchors in shear must be calculated according to ACI 318 Sections D.6.2 and D.6.3, as described in Sections 4.1.7 and 4.1.8 of this report; and, in accordance with ACI 318 Sections D.6.1.2, the appropriate value for nominal steel strength in shear for seismic loads, V_{eq} or $V_{sa,deck,cr}$ described in Table 3 of this report, must be used in lieu of V_{sa} .

4.1.12 Structural Sand-lightweight Concrete: When anchors are used in structural sand-lightweight concrete, N_b , N_{pn} , V_b and V_{cp} must be multiplied by 0.60, in lieu of ACI 318 Section D.3.4. For anchors installed in the soffit of structural sand-lightweight concrete-filled steel deck and floor and roof assemblies, this reduction is not required.

4.2 Allowable Stress Design (ASD):

4.2.1 General: Design values for use with allowable stress design load combinations calculated in accordance with Section 1605.3 of the IBC and Section 1612.3 of the UBC, must be established using the following equations:

$$T_{allowable,ASD} = \phi N_n / \alpha \quad (\text{Eq-5})$$

$$V_{allowable,ASD} = \phi V_n / \alpha \quad (\text{Eq-6})$$

where:

$$T_{allowable,ASD} = \text{Allowable tension load (lbf or kN)}$$

$$V_{allowable,ASD} = \text{Allowable shear load (lbf or kN)}$$

$$\phi N_n = \text{Lowest design strength of an anchor or anchor group in tension as determined in accordance with ACI 318 Appendix D, Section 4.1 of this report and 2006 IBC Section 1908.1.16, as appropriate (lbf or kN).}$$

$$\phi V_n = \text{Lowest design strength of an anchor or anchor group in shear as determined in accordance with ACI 318 Appendix D, Section 4.1 of this report and 2006 IBC Section 1908.1.16, as appropriate (lbf or kN).}$$

α = Conversion factor calculated as a weighted average of the load factors for the controlling load combination. In addition, α must include all applicable factors to account for nonductile failure modes and required over-strength.

Limits on edge distance, anchor spacing and member thickness as given in Table 1 of this report must apply. An example of Allowable Stress Design tension values is given in Table 4.

4.2.2 Interaction of Tensile and Shear Forces: The interaction must be calculated and consistent with ACI 318 Appendix D Section D.7, as follows:

For shear loads $V \leq 0.2V_{allowable,ASD}$, the full allowable load in tension $T_{allowable,ASD}$ must be permitted.

For tension loads $T \leq 0.2T_{allowable,ASD}$, the full allowable load in shear $V_{allowable,ASD}$ must be permitted.

$$\text{For all other cases: } \frac{T}{T_{allowable,ASD}} + \frac{V}{V_{allowable,ASD}} \leq 1.2 \quad (\text{Eq-7})$$

4.3 Installation:

Installation parameters are provided in Table 1, Figure 1 and Figure 4. Anchor locations must comply with this report and plans and specifications approved by the code official. The Wedge-Bolt+ must be installed according to manufacturer's published installation instructions and this report. Anchors must be installed in holes drilled using carbide-tipped masonry drill bits (Wedge-bits) supplied by Powers Fasteners, and complying with the tolerances given in Table 1. The nominal Wedge-bit diameter must be equal to the nominal anchor size. The minimum drilled hole depth is given in Table 1. Dust and debris must be removed from the hole using a hand pump, compressed air or a vacuum. The anchor must be driven into the predrilled hole using a powered impact wrench until the proper nominal embedment depth is achieved. The maximum impact wrench power (torque) must be in accordance with values given in Table 1.

For installation in the soffit of concrete on steel deck assemblies, the hole diameter in the steel deck must not exceed the diameter of the hole in the concrete by more than $1/8$ inch (3.2 mm). For member thickness and edge distance restrictions for installations into the soffit of concrete on steel deck assemblies, see Figure 4.

4.4 Special Inspection:

Special inspection is required, in accordance with Section 1704.13 of the IBC and Section 1701.5.2 of the UBC. The special inspector must be on the jobsite continuously during anchor installation to verify anchor type, anchor dimensions, hole dimensions, concrete type, concrete compressive strength, drill bit type and size, hole cleaning procedures, anchor spacing(s), edge distance(s), concrete member thickness, anchor embedment and impact wrench power. Under the IBC, additional requirements as set forth in Sections 1705 and 1706 must be observed, where applicable.

5.0 CONDITIONS OF USE

The Powers Wedge-Bolt[®]+ screw anchors described in this report comply with, or are suitable alternatives to what is specified in, those codes listed in Section 1.0 of this report, subject to the following conditions:

5.1 The anchors must be installed in accordance with the manufacturer's published installation instructions and this report. In case of a conflict, this report governs.

- 5.2** Anchor sizes, dimensions, and minimum embedment depths are as set forth in this report.
- 5.3** Anchors must be installed in uncracked concrete and structural sand-lightweight concrete [$1/4$ -inch (6.4 mm) anchors]; cracked and uncracked normal-weight concrete [$3/8$ -inch to $3/4$ -inch anchors (9.5 mm to 19.1 mm)] and structural sand-lightweight concrete having a specified compressive strength, f'_c , of 2,500 psi to 8,500 psi (17.2 MPa to 58.6 MPa); and cracked and uncracked normal weight or structural sand-lightweight concrete over steel deck [$3/8$ -inch and $1/2$ -inch anchors (9.5 mm and 12.7 mm)] having a minimum specified compressive strength, f'_c , of 3,000 psi (20.7 MPa).
- 5.4** The values of f'_c used for calculation purposes must not exceed 8,000 psi (55.2 MPa).
- 5.5** Strength design values must be established in accordance with Section 4.1 of this report.
- 5.6** Allowable design values must be established in accordance with Section 4.2 of this report.
- 5.7** Anchor spacing(s) and edge distance(s), and minimum member thickness, must comply with Table 1.
- 5.8** Prior to installation, calculations and details demonstrating compliance with this report must be submitted to the code official. The calculations and details must be prepared by a registered design professional where required by the statutes of the jurisdiction in which the project is to be constructed.
- 5.9** Since an ICC-ES acceptance criteria for evaluating data to determine the performance of anchors subjected to fatigue or shock loading is unavailable at this time, the use of these anchors under such conditions is beyond the scope of this report.
- 5.10** Anchors may be installed in regions of concrete where cracking has occurred or where analysis indicates cracking may occur ($f_t > f_r$), subject to the conditions of this report.
- 5.11** The $1/4$ -inch-diameter (6.4 mm) anchors may be used to resist short-term loading due to wind forces and for seismic load combinations limited to locations designated as Seismic Design Categories A and B, subject to the conditions of this report. The $3/8$ -inch- to $3/4$ -inch-diameter (9.5 mm to 19.1 mm) anchors may be used to resist short-term loading due to wind or seismic forces (Seismic Design Categories A through F), subject to the conditions of this report.
- 5.12** Anchors are not permitted to support fire-resistance-rated construction. Where not otherwise prohibited by code, anchors are permitted for installation in fire-resistance-rated construction provided that at least one of the following conditions is fulfilled:
- The $1/4$ -inch (6.4 mm) anchors are used to resist wind forces only.
 - The $3/8$ -inch to $3/4$ -inch (9.5 mm to 19.1 mm) anchors are used to resist wind or seismic forces only.
 - Anchors that support gravity load-bearing structural elements are within a fire-resistance-rated envelope or a fire-resistance-rated membrane, are protected by approved fire-resistance-rated materials, or have been evaluated for resistance to fire exposure in accordance with recognized standards.
 - Anchors are used to support nonstructural elements.
- 5.13** Anchors have been evaluated for reliability against brittle failure and found to be not significantly sensitive to brittle failure such as hydrogen embrittlement.
- 5.14** Use of anchors is limited to dry, interior locations.
- 5.15** Special inspection must be provided in accordance with Sections 4.4.
- 5.16** Anchors are manufactured under an approved quality control program with inspections by CEL Consulting (AA-639).
- 6.0 EVIDENCE SUBMITTED**
- 6.1** Data in accordance with the ICC-ES Acceptance Criteria for Mechanical Anchors in Concrete Elements (AC193), dated May 2008, for use in cracked and uncracked concrete; including optional suitability tests 12 and 13 (AC193, Table 4.2) for seismic tension and shear.
- 6.2** Quality control documentation.
- 7.0 IDENTIFICATION**
- The Wedge-Bolt+ anchors are identified in the field by dimensional characteristics and packaging. A diameter and length marking is stamped on the hex head of each anchor, along with a plus sign; these are visible after installation. Packages are identified with the anchor name; part number; type; anchor size and length; quantity; the Powers Fasteners, Inc., name; the name of the inspection agency (CEL, AA-639); and the evaluation report number (ICC-ES ESR-2526).

TABLE 1—POWERS WEDGE-BOLT+ SCREW ANCHOR INSTALLATION SPECIFICATIONS

Anchor Property / Setting Information	Notation	Units	Nominal Anchor Size (inch)					
			1/4	3/8	1/2	5/8	3/4	
Nominal anchor diameter	d_o	in. (mm)	0.250 (6.4)	0.375 (9.5)	0.500 (12.7)	0.625 (15.9)	0.750 (19.1)	
Minimum diameter of hole clearance in fixture	d_h	in. (mm)	5/16 (7.9)	7/16 (11.1)	9/16 (14.3)	11/16 (17.5)	13/16 (20.6)	
Nominal drill bit diameter	d_{bit}	in.	1/4 Wedge-bit	3/8 Wedge-bit	1/2 Wedge-bit	5/8 Wedge-bit	3/4 Wedge-bit	
Wedge-bit tolerance range	-	in.	0.255 to 0.259	0.385 to 0.389	0.490 to 0.495	0.600 to 0.605	0.720 to 0.725	
Minimum nominal embedment depth	h_{nom}	in. (mm)	1-3/4 (44)	2-1/8 (54)	2-1/2 (64)	3-1/2 (89)	3-1/4 (83)	4-3/8 (111)
Effective embedment	h_{ef}	in. (mm)	1.100 (28)	1.426 (36)	1.652 (42)	2.502 (64)	2.146 (55)	3.102 (79)
Minimum hole depth ¹	h_o	in. mm	2 (51)	2-1/2 (64)	3 (76)	4 (102)	4 (101)	5 (127)
Minimum member thickness ¹	h_{min}	in. (mm)	4 (102)	4 (102)	5 (127)	6 (152)	6 (152)	7 (178)
Minimum overall anchor length	ℓ_{anch}	in. (mm)	2-1/4 (57)	2-1/2 (64)	3 (76)	4 (102)	4 (102)	5 (127)
Minimum edge distance ¹	c_{min}	in. (mm)	2-3/4 (70)	2-1/4 (57)	3 (76)	3 (76)	4 (102)	4 (102)
Minimum edge distance, close edge condition ²	c_{min}	in. (mm)	-	1-3/4 (44)	1-3/4 (44)	1-3/4 (44)	1-3/4 (44)	1-3/4 (44)
Minimum spacing distance ¹	s_{min}	in. (mm)	4 (102)	3 (76)	4 (102)	4 (102)	5 (127)	5 (127)
Critical edge distance ¹	c_{ac}	in. (mm)	2-3/4 (70)	3-1/4 (83)	3 (76)	4 (102)	4 (102)	5 (127)
Maximum impact wrench power (torque)	T_{screw}	ft.-lb. (N-m)	115 (156)	245 (332)	300 (407)	350 (475)	400 (542)	
Impact wrench socket size	-	in.	7/16	9/16	3/4	15/16	1-1/8	
Head height	-	in.	7/32	21/64	7/16	1/2	19/32	

For SI: 1 inch = 25.4 mm, 1 ft-lb = 1.356 N-m.

¹ For installations through the soffit of steel deck into concrete, see the installation detail. Anchors in the lower flute may be installed with a maximum 1-inch offset in either direction from the center of the flute. In addition, anchors shall have an axial spacing along the flute equal to the greater of $3h_{ef}$ or 1.5 times the flute width.

² For installations in concrete (excluding the soffit of steel deck) with the listed edge distance, the anchor spacing distance must be equal to or greater than $5h_{nom}$.

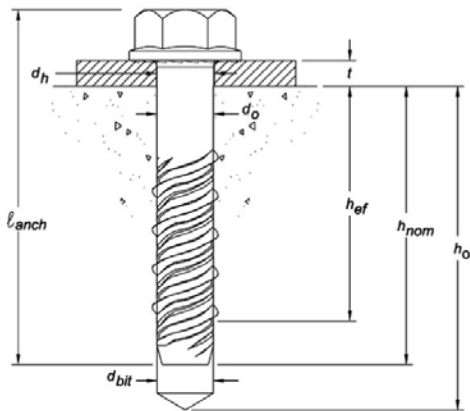

FIGURE 1—WEDGE-BOLT+ ANCHOR DETAIL

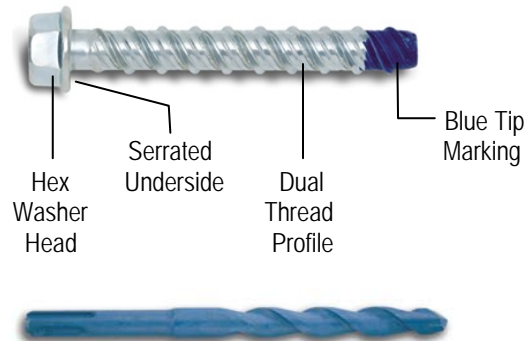
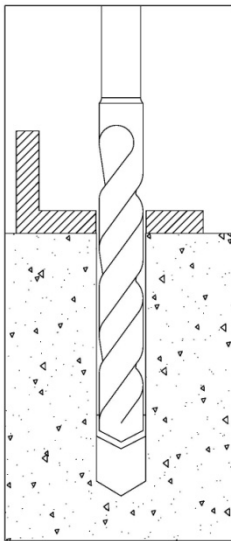
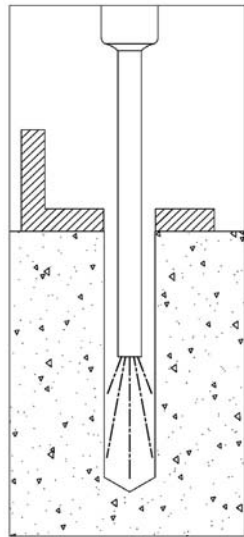

FIGURE 2—WEDGE-BOLT+ ANCHOR AND WEDGE-BIT



1.) Using the proper Wedge-bit drill bit size, drill a hole into the base material to the required depth. The tolerances of the carbide Wedge-bit used must meet the requirements of the published Wedge-bit range in Table 1.



2.) Remove dust and debris from the hole using a hand pump, compressed air or vacuum.

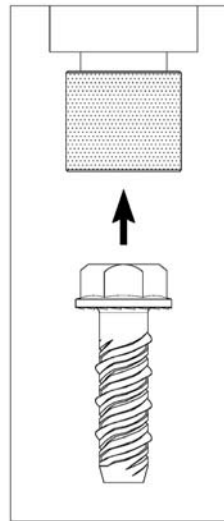

3.) Select a powered impact wrench that does not exceed the maximum torque, T_{screw} , for the selected anchor diameter (Table 1). Attach an appropriate sized hex socket to the impact wrench. Mount the screw anchor head into the socket.

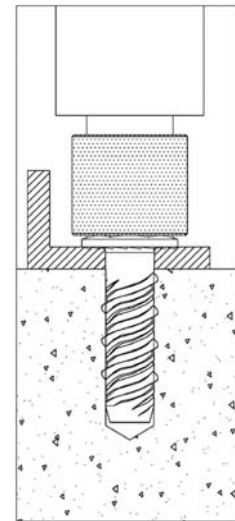

4.) Drive the anchor with an impact wrench through the fixture and into the hole until the head of the anchor comes into contact with the fixture. The anchor must be snug after installation. Do not spin the hex socket off the anchor to disengage.

FIGURE 3—WEDGE-BOLT+ INSTALLATION INSTRUCTIONS

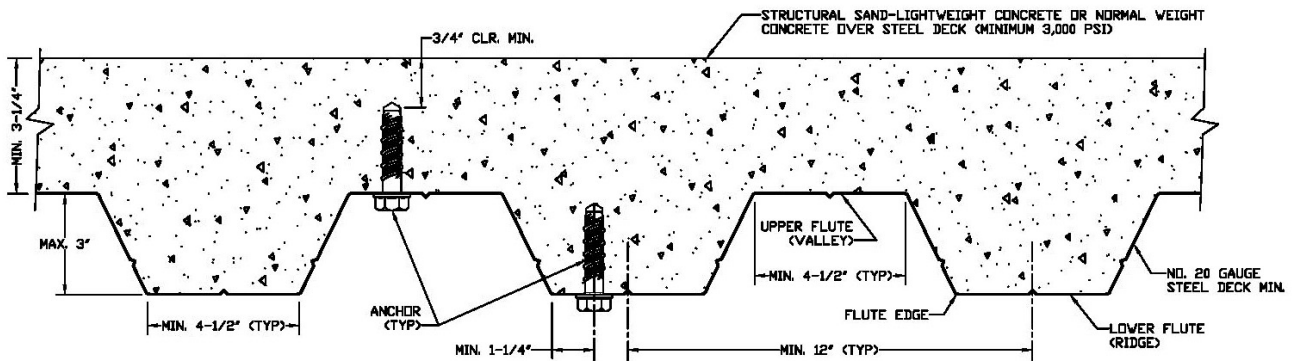

FIGURE 4—WEDGE-BOLT+ INSTALLATION DETAIL FOR ANCHORS IN THE SOFFIT OF CONCRETE OVER STEEL DECK FLOOR AND ROOF ASSEMBLIES

TABLE 2—TENSION DESIGN INFORMATION FOR POWERS WEDGE-BOLT+ SCREW ANCHORS IN CONCRETE

(For use with load combinations taken from ACI 318, Section 9.2)^{1,2}

Design Characteristic	Notation	Units	Nominal Anchor Size (inch)						
			1/4	3/8	1/2	5/8	3/4		
Anchor category	1, 2 or 3	-	1	1	1	1	1	1	
Nominal embedment depth	h_{nom}	in.	1-3/4	2-1/8	2-1/2	3-1/2	3-1/4	4-3/8	4-1/4
STEEL STRENGTH IN TENSION⁴									
Minimum specified ultimate strength	f_{uta}^{11}	ksi (N/mm ²)	100 (689)	100 (689)	100 (689)	100 (689)	100 (689)	100 (689)	100 (689)
Effective tensile stress area	A_{se}	in ² (mm ²)	0.044 (28.4)	0.103 (66.5)	0.168 (108.4)	0.249 (160.6)	0.249 (160.6)	0.371 (239.4)	0.371 (239.4)
Steel strength in tension	N_{sa}^{11}	lb (kN)	4,400 (19.6)	10,300 (45.8)	16,800 (74.7)	16,800 (74.7)	24,900 (110.7)	24,900 (110.7)	37,100 (164.9)
Reduction factor for steel strength ³	ϕ	-	0.65						
CONCRETE BREAKOUT STRENGTH IN TENSION⁹									
Effective embedment	h_{ef}	in. (mm)	1.100 (28)	1.426 (36)	1.652 (42)	2.502 (64)	2.146 (55)	3.102 (79)	2.909 (74)
Effectiveness factor for uncracked concrete	k_{uncr}	-	24	24	24	24	24	24	24
Effectiveness factor for cracked concrete	k_{cr}	-	Not Applicable	17	17	17	17	17	17
Ratio of k_{uncr}/k_{cr}^5	$\psi_{c,N}^{11}$	-	1.41 See note 5	1.41 See note 5	1.41 See note 5	1.41 See note 5	1.41 See note 5	1.41 See note 5	1.41 See note 5
Reduction factor for concrete breakout strength ³	ϕ	-	0.65 (Condition B)						
PULLOUT STRENGTH IN TENSION (NON-SEISMIC APPLICATIONS)⁹									
Characteristic pullout strength, uncracked concrete (2,500 psi) ⁶	$N_{p,uncr}$	lb (kN)	See note 7	See note 7	See note 7	See note 7	See note 7	See note 7	See note 7
Characteristic pullout strength, cracked concrete (2,500 psi) ⁶	$N_{p,cr}$	lb (kN)	Not Applicable	See note 7	See note 7	2,965 (13.2)	3,085 (13.7)	4,290 (19.1)	See note 7
Reduction factor for pullout strength ³	ϕ	-	0.65 (Condition B)						
PULLOUT STRENGTH IN TENSION FOR SEISMIC APPLICATIONS⁹									
Characteristic pullout strength, seismic (2,500 psi) ^{6,8}	N_{eq}	lb (kN)	Not Applicable	1,085 (4.8)	1,350 (6.0)	2,520 (11.2)	3,085 (13.7)	4,290 (19.1)	4,270 (19.0)
Reduction factor for pullout strength ³	ϕ	-	0.65 (Condition B)						
PULLOUT STRENGTH IN TENSION FOR STRUCTURAL SAND-LIGHTWEIGHT AND NORMAL-WEIGHT CONCRETE OVER STEEL DECK									
Characteristic pullout strength, uncracked concrete over steel deck ¹⁰	$N_{p,deck,uncr}$	lb (kN)	Not Applicable	2,010 (8.9)	2,480 (11.0)	2,480 (11.0)	Not Applicable	Not Applicable	Not Applicable
Characteristic pullout strength, cracked concrete over steel deck ¹⁰	$N_{p,deck,cr}$	lb (kN)	Not Applicable	1,425 (6.3)	1,755 (7.8)	1,755 (7.8)	Not Applicable	Not Applicable	Not Applicable
Reduction factor for pullout strength, concrete over steel deck ³	ϕ	-	0.65 (Condition B)						

¹ The data in this table is intended to be used with the design provisions of ACI 318 Appendix D; for anchors resisting seismic load combinations the additional requirements of Section D.3.3 shall apply.

² Installation must comply with published instructions and details.

³ All values of ϕ were determined from the load combinations of IBC Section 1605.2, ACI 318 Section 9.2, or UBC Section 1612.2. If the load combinations of Appendix C or UBC, Section 1909.2 are used, the appropriate value of ϕ must be determined in accordance with ACI 318 Section D.4.5. For reinforcement that complies with ACI 318 Appendix D requirements for Condition A, ACI 318 Section D.4.4 provides the appropriate ϕ factor.

⁴ The Wedge-Bolt+ is considered a brittle steel element as defined by ACI 318 Section D.1.

⁵ Select the appropriate effectiveness factor for cracked concrete (k_{cr}) or uncracked concrete (k_{uncr}) and use $\psi_{c,N}=1.0$. The value of $\psi_{c,N}=1.41$ describes the ratio of k_{uncr}/k_{cr} and must be disregarded in ACI 318 Section D.5.2.6 (Equation D-4 and D-5).

⁶ For concrete compressive strengths greater than 2,500 psi, $N_{pn} = (\text{pullout strength from table}) \times (\text{specified compressive strength}/2500)^{0.5}$.

⁷ Pullout strength will not control design of indicated anchors. Pullout strength need not be calculated for indicated anchor size and embedment.

⁸ Reported values for characteristic pullout strength in tension for seismic applications are based on test results per ACI 355.2, Section 9.5.

⁹ Anchors are permitted to be used in structural sand-lightweight concrete provided that N_b and N_{pn} are multiplied by a factor of 0.60.

¹⁰ Values for $N_{p,deck}$ are for structural sand-lightweight concrete ($f'_{c,min} = 3,000$ psi) and additional lightweight concrete reduction factors need not be applied.

In addition, evaluation for the concrete breakout capacity in accordance with ACI 318 Section D.5.2 is not required for anchors installed in the flute (soffit).

¹¹ For 2003 IBC code basis, replace f_{uta} with f_{ut} ; N_{sa} with N_s ; $\psi_{c,N}$ with ψ_3 and N_{eq} with $N_{p,seis}$.

TABLE 3—SHEAR DESIGN INFORMATION FOR POWERS WEDGE-BOLT+ SCREW ANCHORS IN CONCRETE

(For use with load combinations taken from ACI 318, Section 9.2)^{1,2}

Design Characteristic	Notation	Units	Nominal Anchor Size (inch)						
			1/4	3/8	1/2	5/8	3/4		
Anchor category	1, 2 or 3	-	1	1	1	1	1	1	
Nominal embedment depth	h_{nom}	in.	1-3/4	2-1/8	2-1/2	3-1/2	3-1/4	4-3/8	4-1/4
STEEL STRENGTH IN SHEAR⁴									
Steel strength in shear ⁵	V_{sa} ¹⁰	lb (kN)	2,475 (11.0)	4,825 (21.5)	7,980 (35.5)	11,990 (53.3)	19,350 (86.1)		
Reduction factor for steel strength ³	ϕ	-	0.60						
CONCRETE BREAKOUT STRENGTH IN SHEAR⁷									
Load bearing length of anchor (h_{ef} or $8d_o$, whichever is less)	ℓ_e ¹⁰	in. (mm)	1.100 (28)	1.426 (36)	1.652 (42)	2.502 (64)	2.146 (55)	3.102 (79)	2.909 (74)
Nominal anchor diameter	d_o	in. (mm)	0.250 (6.4)	0.375 (9.5)	0.500 (12.7)	0.625 (15.9)	0.750 (19.1)		
Reduction factor for concrete breakout strength ³	ϕ	-	0.65 (Condition B)						
CONCRETE PRYOUT STRENGTH IN SHEAR⁷									
Coefficient for pryout strength; 1.0 for $h_{ef} < 2.5$ in., 2.0 for $h_{ef} \geq 2.5$ in.	k_{cp}	-	1.0	1.0	1.0	2.0	1.0	2.0	2.0
Effective embedment	h_{ef}	in. (mm)	1.100 (28)	1.426 (36)	1.652 (42)	2.502 (64)	2.146 (55)	3.102 (79)	2.909 (74)
Reduction factor for pryout strength ³	ϕ	-	0.65 (Condition B)						
STEEL STRENGTH IN SHEAR FOR SEISMIC APPLICATIONS⁷									
Steel strength in shear, seismic ⁶	V_{eq} ¹⁰	lb (kN)	Not Applicable	3,670 (16.3)	7,980 (35.5)	11,990 (53.3)	12,970 (57.7)		
Reduction factor for steel strength in shear for seismic ³	ϕ	-	0.60						
STEEL STRENGTH IN SHEAR FOR STRUCTURAL SAND-LIGHTWEIGHT AND NORMAL-WEIGHT CONCRETE OVER STEEL DECK⁹									
Steel strength in shear, concrete over steel deck ⁸	$V_{sa,deck}$	lb (kN)	Not Applicable	1,640 (7.3)	3,090 (13.7)	Not Applicable	Not Applicable	Not Applicable	
Reduction factor for steel strength in shear for concrete over steel deck ³	ϕ	-	0.60						

¹ The data in this table is intended to be used with the design provisions of ACI 318 Appendix D; for anchors resisting seismic load combinations the additional requirements of Section D.3.3 shall apply.

² Installation must comply with published instructions and details.

³ All values of ϕ were determined from the load combinations of IBC Section 1605.2, ACI 318 Section 9.2, or UBC Section 1612.2. If the load combinations of Appendix C or UBC, Section 1909.2 are used, the appropriate value of ϕ must be determined in accordance with ACI 318 Section D.4.5. For reinforcement that complies with ACI 318 Appendix D requirements for Condition A, see ACI 318 Section D.4.4 provides the appropriate ϕ factor.

⁴ The Wedge-Bolt+ is considered a brittle steel element as defined by ACI 318 Section D.1.

⁵ Reported values for steel strength in shear are based on test results per ACI 355.2, Section 9.4 and must be used for design. These reported values may be lower than calculated results using equation D-20 in ACI 318-05, Section D.6.1.2 and D-18 in ACI 318-02, Section D.6.1.2.

⁶ Reported values for steel strength in shear for seismic applications are based on test results in accordance with ACI 355.2, Section 9.6.

⁷ Anchors are permitted to be used in structural sand-lightweight concrete provided that V_b and V_{cp} are multiplied by a factor of 0.60.

⁸ Values of $V_{sa,deck}$ are for structural sand-lightweight concrete ($f'_{c, min} = 3,000$ psi) and additional lightweight concrete reduction factors need not be applied. In addition, evaluation for the concrete breakout capacity in accordance with ACI 318 Section D.6.2 and the pryout capacity in accordance with Section D.6.3 are not required for anchors installed in the flute (soffit).

⁹ Shear loads for anchors installed through steel deck into concrete may be applied in any direction.

¹⁰ For 2003 IBC code basis replace V_{sa} with V_s ; and ℓ_e with ℓ . and V_{eq} with $V_{sa,seis}$.

TABLE 4—Example Allowable Stress Design Values for Illustrative Purposes^{1,2,3,4,5,6,7,8}

Nominal Anchor Diameter (in.)	Nominal Embedment Depth (in.)	Effective Embedment (in.)	Allowable Tension Load (lbs)
1/4	1-3/4	1.100	610
3/8	2-1/8	1.426	895
1/2	2-1/2	1.652	1,120
	3-1/2	2.502	2,085
5/8	3-1/4	2.146	1,655
	4-3/8	3.102	2,880
3/4	4-1/4	2.909	2,615

¹ Single anchor with static tension load only.

² Concrete determined to remain uncracked for the life of the anchorage.

³ Load combinations from ACI 318 Section 9.2 (no seismic loading).

⁴ 30% dead load and 70% live load, controlling load combination $1.2D + 1.6L$.

⁵ Calculated of weighted average for $\alpha = 1.2(0.3+1.6(0.7)) = 1.48$.

⁶ $f'_c = 2,500$ psi (normal weight concrete).

⁷ $C_{a1} = C_{a2} \geq C_{ac}$.

⁸ $h \geq h_{min}$.

Given: Calculate the factored resistance strength, ϕN_n , and the allowable stress design value, $T_{allowable,ASD}$, for a $3/8$ -inch diameter Wedge-Bolt+ screw anchor assuming the given conditions in Table 4.		
Calculation in accordance with ACI 318-05 Appendix D and this report:	Code Ref.	Report Ref.
Step 1. Calculate steel strength of a single anchor in tension: $\phi N_{sa} = (0.65)(10,300) = 6,695 \text{ lbs.}$	D.5.1.2	Table 2
Step 2. Calculate concrete breakout strength of a single anchor in tension: $\phi N_{cb} = \phi \frac{A_{Nc}}{A_{Nc0}} \psi_{ed,N} \psi_{c,N} \psi_{cp,N} N_b$ $N_b = k_c \sqrt{f'_c} (h_{ef})^{1.5}$ $N_b = (24) \sqrt{2,500} (1.426)^{1.5} = 2,043 \text{ lbs.}$ $\phi N_{cb} = (0.65) \frac{(18.3)}{(18.3)} (1.0)(1.0)(1.0)(2,043) = 1,328 \text{ lbs.}$	D.5.2.1 D.5.2.2	Table 2 Table 2
Step 3. Calculate pullout strength: $\phi N_{pn} = \phi N_{p,uncr} \psi_{c,p}$ $\phi N_{pn} = n/a \text{ (pullout strength does not control)}$	D.5.3.2	Table 2 Table 2
Step 4. Determine controlling resistance strength in tension: $\phi N_n = \min[\phi N_{sa}, \phi N_{cb}, \phi N_{pn}] = \phi N_{cb} = 1,328 \text{ lbs.}$	D.4.1.1	
Step 5. Calculate allowable stress design conversion factor for loading condition: Controlling load combination: $1.2D + 1.6L$ $\alpha = 1.2(30\%) + 1.6(70\%) = 1.48$	9.2	
Step 6. Calculate allowable stress design value: $T_{allowable,ASD} = \frac{\phi N_n}{\alpha} = \frac{1,328}{1.48} = 897 \text{ lbs.}$		Sec. 4.2

FIGURE 5—EXAMPLE CALCULATION FOR ILLUSTRATIVE PURPOSES

ICC Evaluation Service, Inc.www.icc-es.org**Business/Regional Office** ■ 5360 Workman Mill Road, Whittier, California 90601 ■ (562) 699-0543
Regional Office ■ 900 Montclair Road, Suite A, Birmingham, Alabama 35213 ■ (205) 599-9800
Regional Office ■ 4051 West Flossmoor Road, Country Club Hills, Illinois 60478 ■ (708) 799-2300**DIVISION: 03—CONCRETE****Section: 03151—Concrete Anchoring****REPORT HOLDER:****POWERS FASTENERS, INC.****2 POWERS LANE****BREWSTER, NEW YORK 10509****(914) 235-6300 or (800) 524-3244**www.powers.comengineering@powers.com**EVALUATION SUBJECT:****POWERS WEDGE-BOLT+ SCREW ANCHORS IN CRACKED AND UNCRACKED CONCRETE****1.0 EVALUATION SCOPE****Compliance with the following codes:**

- 2007 *Florida Building Code—Building*
- 2007 *Florida Building Code—Residential*

Property Evaluated:

Structural

2.0 PURPOSE OF THIS SUPPLEMENT

This supplement is issued to indicate that the Powers Wedge-Bolt+ Screw Anchors in uncracked concrete [$1/4$ -inch (6.4 mm)] and in cracked and uncracked concrete [$3/8$ -inch to $3/4$ -inch (9.5 mm to 19.1 mm)] as described in the master report comply with the 2007 *Florida Building Code—Building* and the 2007 *Florida Building Code—Residential*, when designed and installed in accordance with the master evaluation report.

Use of the Powers Wedge-Bolt+ Screw Anchors in uncracked concrete [$1/4$ -inch (6.4 mm)] and in cracked and uncracked concrete [$3/8$ -inch to $3/4$ -inch (9.5 mm to 19.1 mm)] as described in the master evaluation report to comply with the High Velocity Hurricane Zone Provisions of the 2007 *Florida Building Code—Building* has not been evaluated, and is outside the scope of this supplement.

This supplement expires concurrently with the master report issued on December 1, 2008.