

1 PLAN - TYPICAL GABS GLASS AWNING SYSTEM

Scale: 1 : 5

STRUCTURAL DISCLAIMER:

ALL CUSTOMERS WHO IN ANY WAY UTILIZE THIS PRODUCT ARE SOLELY RESPONSIBLE TO CONSULT A STRUCTURAL ENGINEER TO DETERMINE THE SUITABILITY OF THE PRODUCT FOR THE INTENDED USE AND SITE CONDITIONS. ALL INSTALLERS MUST BE QUALIFIED AND HAVE PROFESSIONAL KNOWLEDGE ABOUT COMPLIANCE WITH LOCAL, STATE AND FEDERAL REGULATIONS, SAFETY FACTORS, AND THE APPROPRIATE CHOICE OF FIXING MATERIAL AND PROCEDURES.

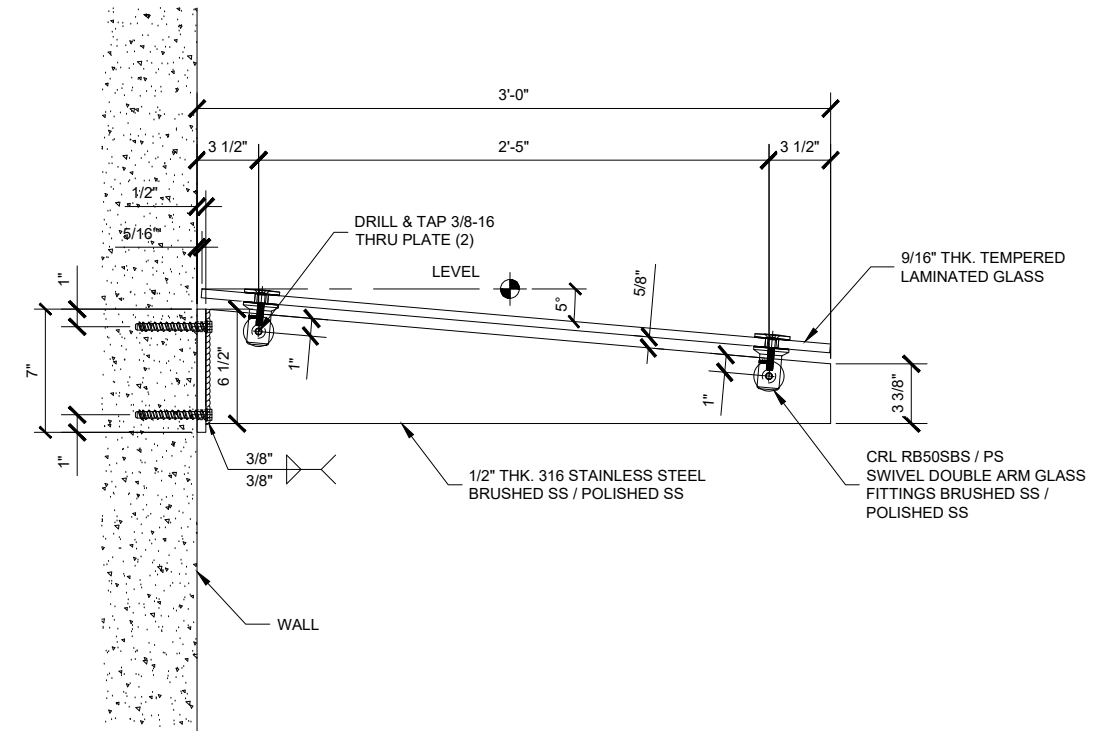

2 SECTION THRU 36" PANEL, 5° SLOPE - GABS36BS / PS

Scale: 1 : 5

- GABS24BS/PS = 24" PROJECTION
- GABS36BS/PS = 36" PROJECTION
- GABS48BS/PS = 48" PROJECTION

Description:
CRL GABS
SLOPED GLASS AWNING
SUPPORT SYSTEM

Drawn By: JO
Date: 02/08/2019
Scale: AS NOTED
File Name:
SYS0101A_GAB_WALL_MNT

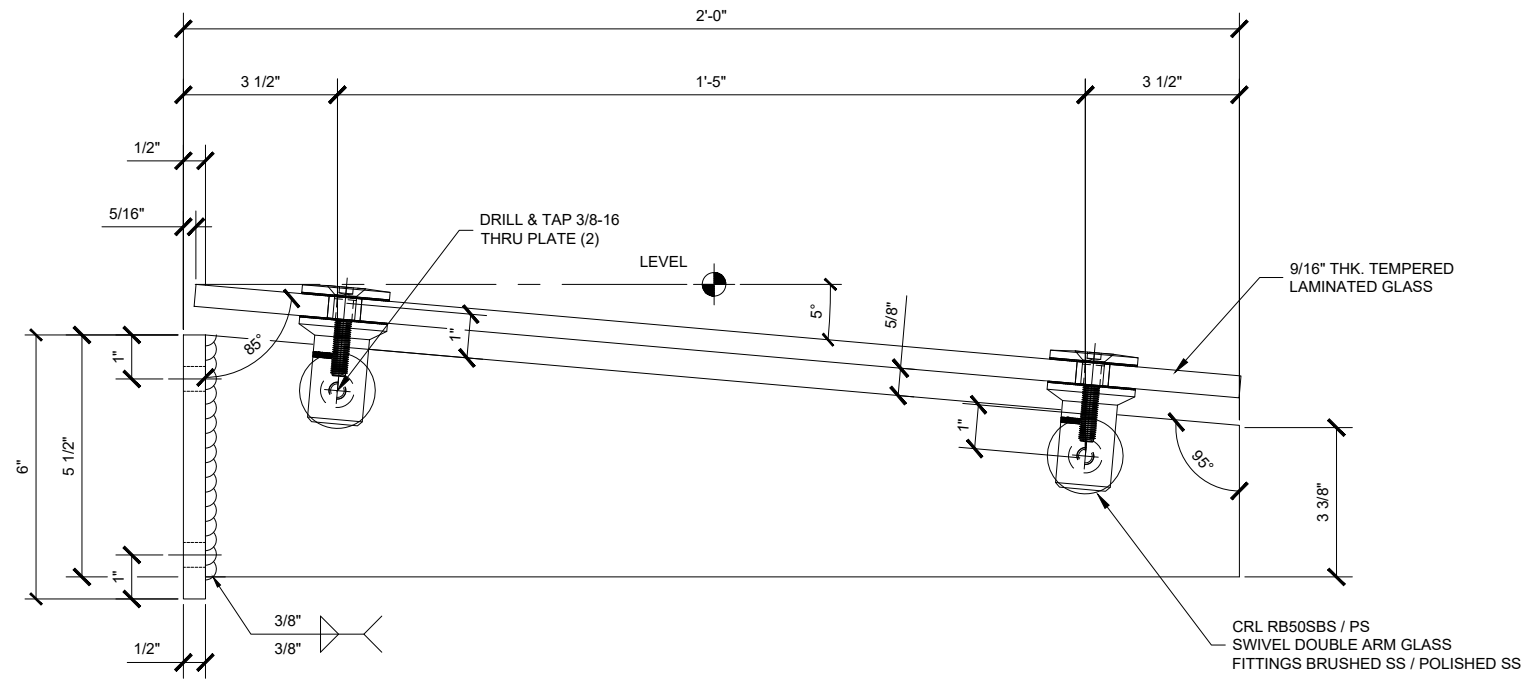

1 CRL GABS24 - 24" GLASS AWNING BRACKET - 5% SLOPE
 Scale: 1 : 5

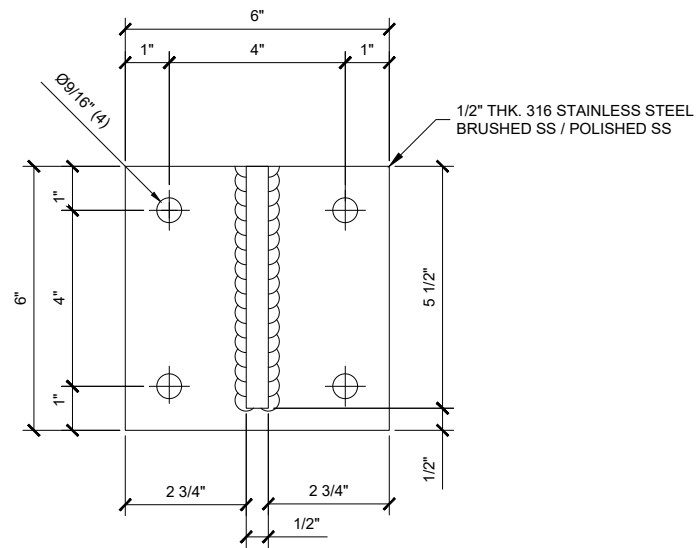

2 BASE PLATE DETAIL
 Scale: 6" = 1'-0"

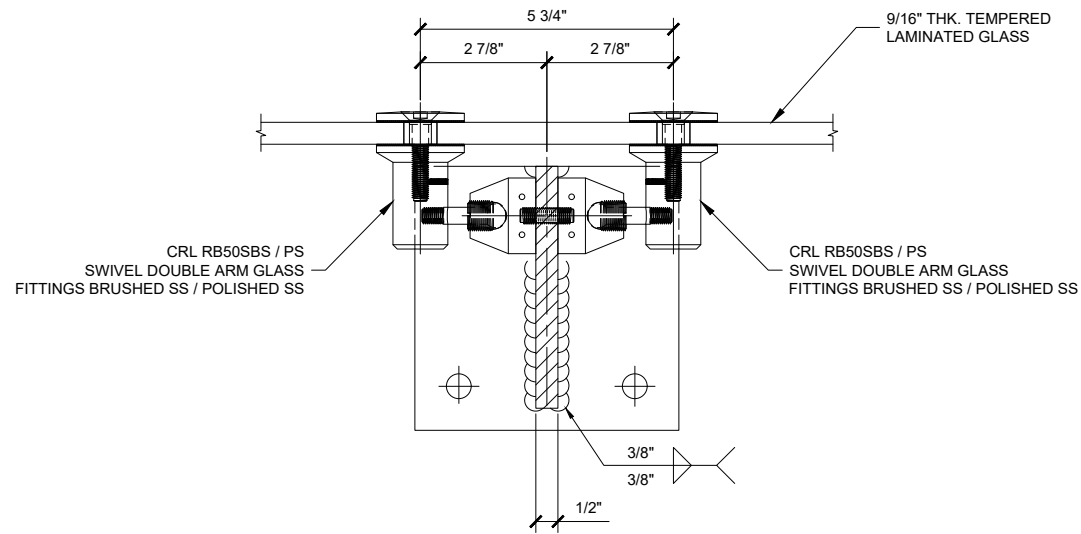

3 GLASS FITTING DETAIL
 Scale: 6" = 1'-0"

Revisions By:



Description:
CRL GABS
SLOPED GLASS AWNING
SUPPORT SYSTEM

Drawn By: JO
Date: 02/08/2019
Scale: AS NOTED
File Name:
SYS0101A_GAB_WALL_MNT

Sheet

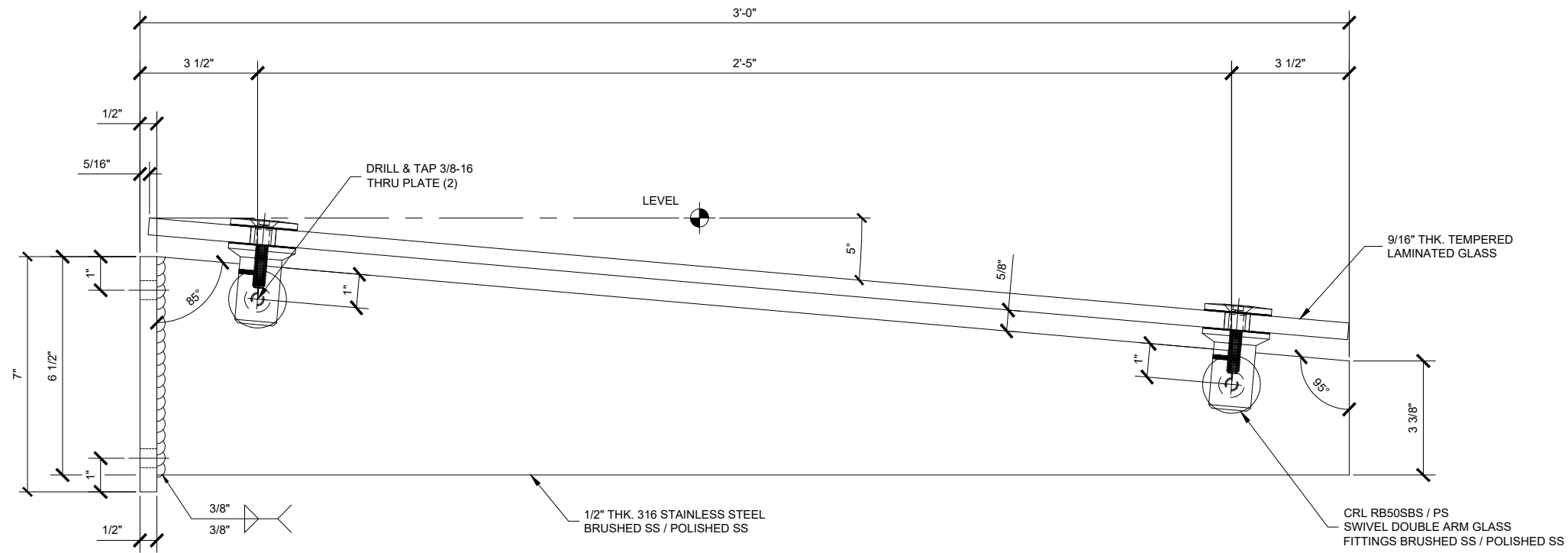

1 CRL GABS36 - 36" GLASS AWNING BRACKET - 5% SLOPE
Scale: 6" = 1'-0"

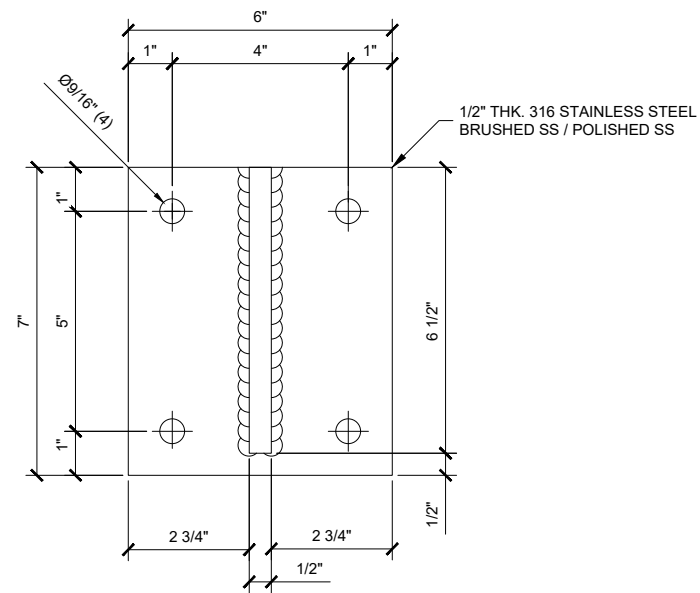

2 BASE PLATE DETAIL
Scale: 6" = 1'-0"

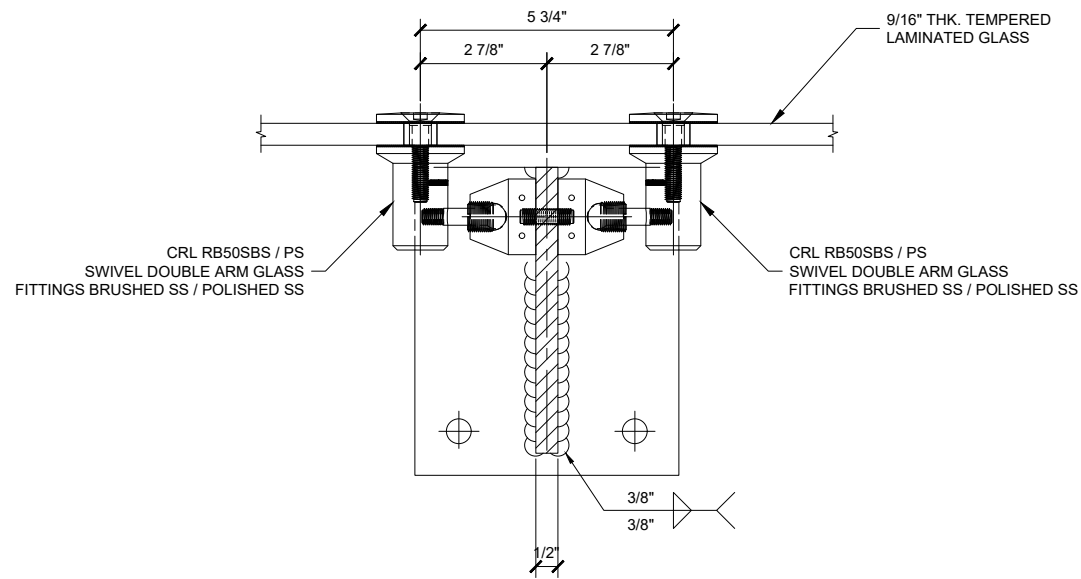

3 GLASS FITTING DETAIL
Scale: 6" = 1'-0"

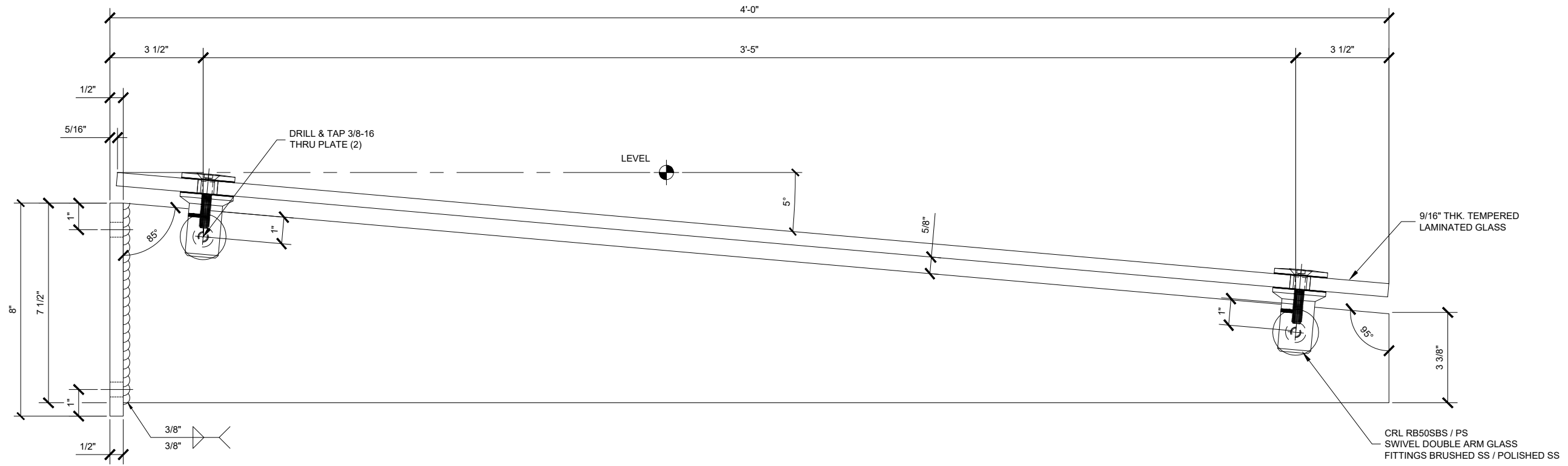

1 CRL GABS48 - 48" GLASS AWNING BRACKET - 5% SLOPE
 Scale: 1 : 5

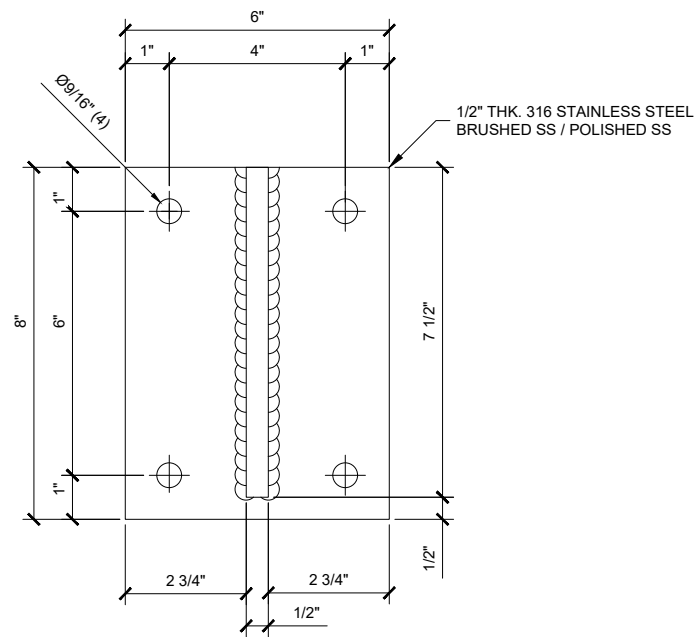

2 BASE PLATE DETAIL
 Scale: 6" = 1'-0"

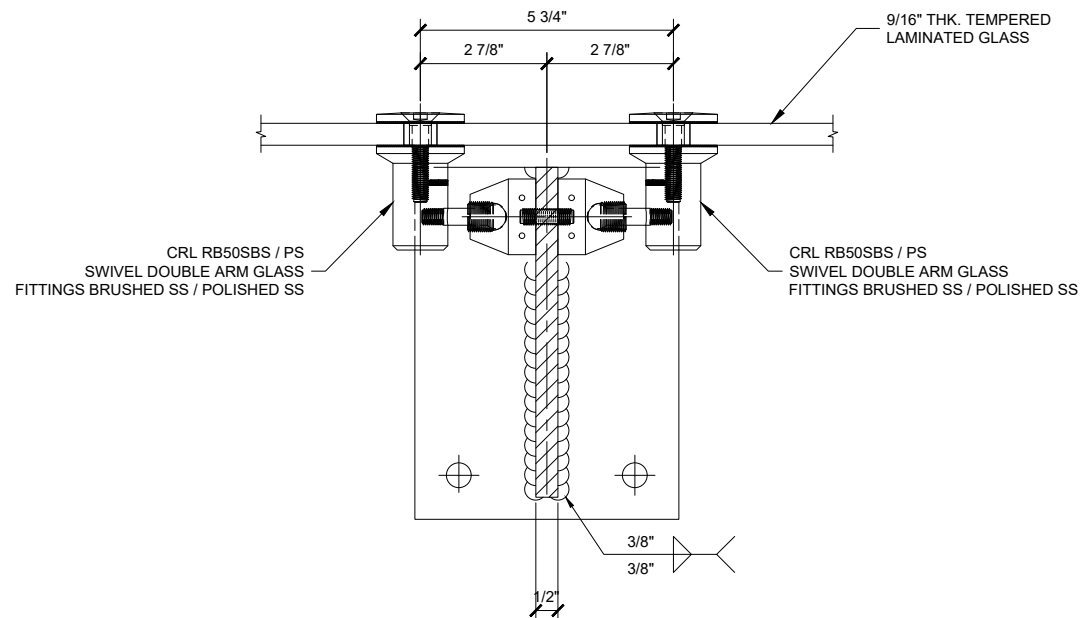

3 GLASS FITTING DETAIL
 Scale: 6" = 1'-0"

Description:
 CRL GABS
 SLOPED GLASS AWNING
 SUPPORT SYSTEM

Drawn By: JO
 Date: 02/08/2019
 Scale: AS NOTED
 File Name:
 SYS0101A_GAB_WALL_MNT
 Sheet