



**H0258.04-303-11-R2  
ACOUSTICAL PERFORMANCE TEST REPORT  
ASTM E90**

**Rendered to:**

**CR LAURENCE CO., INC.**

**Series/Model: 487-AR**

**Type: Office Partition**

**Glazing: 1/4" Laminate Interior, 3-1/2" Air Space, 3/8" Laminate Exterior**

**STC: 47**

**OITC: 40**

Reference should be made to Intertek-ATI Report No. H0258.04-303-11 for complete test specimen description. This page alone is not a complete report. Flanking limit tests and reference specimen tests are available upon request.



## Acoustical Performance Test Report

CR LAURENCE CO., INC.  
2100 East 38th Street  
Vernon, California 90058

Report No H0258.04-303-11  
Test Date 04/19/17  
Report Date 05/16/17  
Revision 2 Date 05/26/17

### Project Scope

Architectural Testing, Inc., an Intertek company ("Intertek-ATI"), was contracted to conduct a sound transmission loss test. The complete test data is included as Appendix B of this report. The client provided the test specimen.

### Test Methods

Testing for this project was conducted in accordance with the following standards. The equipment listed in the attachments meets the requirements of the following standards.

ASTM E90-09(2016), *Standard Test Method for Laboratory Measurement of Airborne Sound Transmission Loss of Building Partitions and Elements*

ASTM E413-10, *Classification for Rating Sound Insulation*

ASTM E1332-10a, *Standard Classification for Rating Outdoor-Indoor Sound Attenuation*

ASTM E2235-04(2012), *Standard Test Method for Determination of Decay Rates for Use in Sound Insulation Test Methods*

### Test Procedure

All measurements were conducted in the HT test chambers at Intertek-ATI located in Lake Forest, California. The sensitivity of the microphones was checked before measurements were conducted.

The transmission loss values were obtained for a single direction of measurement. Two background noise sound pressure level and five sound absorption measurements were conducted at each of five microphone positions. Two sound pressure levels were made simultaneously in the receive and source rooms at each of five microphone positions. The air temperature and relative humidity conditions were monitored and recorded during all measurements.

### Specimen Installation

A sound transmission loss test was initially performed on a filler wall. The specimen plug was removed from the filler wall assembly. The specimen was placed on a foam isolation pad in the test opening. Duct seal was used to seal the perimeter of the specimen to the test opening on both sides. The interior side of the specimen, when installed, was approximately 1/4" from being flush with the receive room side of the filler wall. A stethoscope was used to check for any abnormal air leaks around the test specimen prior to testing. Operable portions of the test specimen, if any, were cycled at least five times prior to testing.

### Test Calculations

Transmission loss (TL) at each 1/3 octave frequency is the average source room sound pressure level minus the average receive room sound pressure level, plus, 10 times the log of the specimen area divided by the sound absorption of the receive room with the sample in place.

### STC Rating

To obtain the Sound Transmission Class (STC), read the TL of the contour curve at 500 Hz. The sum of the deficiencies below the contour curve must not exceed 32. The maximum deficiency at any one frequency must not exceed 8.

### OITC Rating

The Outdoor-Indoor Transmission Class (OITC) is calculated by subtracting the logarithmic summation of the TL values from the logarithmic summation of the A-weighted transportation noise spectrum stated in ASTM E1332.

### Specimen Descriptions

		<b>Frame</b>
<b>Size</b>		78-7/8" by 78-7/8"
<b>Thickness</b>		5-1/4"
	Corners	Mitered and Butted
	Fasteners	Screws
	Seal Method	N/A
<b>Material</b>		Aluminum
	Reinforcement	N/A
	Thermal Break Material	N/A
<b>Daylight Opening Size (X2)</b>		75-1/2" by 36-5/8"

**Specimen Descriptions (Continued)**

<b>Measured Overall Interior Glass Thickness</b>	0.115", 0.060" PVB, 0.115"
<b>Interior Glass Type</b>	Laminate
<b>Measured Overall Exterior Glass Thickness</b>	0.174", 0.060" PVB, 0.174"
<b>Exterior Glass Type</b>	Laminate

TYPE	QUANTITY	LOCATION
<b>Weatherstrip</b>		
No weatherstrip		
<b>Hardware</b>		
No hardware		
<b>Drainage</b>		
No Drainage		

<b>Total Weight</b> (lbs)	<b>Average Weight</b> (lbs / ft <sup>2</sup> )
326	7.36

\* - Stated per Client/Manufacturer, N/A-Not Applicable

**Comments**

A drawing of the test specimen are included in Appendix C. The specimen was returned per the client's request.

Intertek-ATI will service this report for the entire test record retention period. Test records, such as detailed drawings, datasheets, representative samples of test specimens, or other pertinent project documentation, will be retained by Intertek-ATI for the entire test record retention period. The test record retention period ends four years after the test date.

This report does not constitute certification of this product nor an opinion or endorsement by this laboratory. It is the exclusive property of the client so named herein and relates only to the specimen tested. This report is intended to help in the client's quality assurance program, but it does not represent a continuous or exhaustive evaluation of the specimen tested or of other products or materials that were not evaluated. The statements and data provided herein do not constitute approval, disapproval, certification, or acceptance of performance or materials.

**This report may not be reproduced, except in full, without the written approval of Intertek-ATI.**

For INTERTEK-ATI:

---

Leeland S. Hoover  
Technician I - Acoustical Testing

---

Bradlay D. Hunt  
Laboratory Manager – Acoustical Testing

LSH:bh/ss

Attachments (pages): This report is complete only when all attachments listed are included.

- Appendix A: Equipment description (1)
- Appendix B: Complete test results (2)
- Appendix C: Photographs (1)
- Appendix D: Drawings (3)

### Revision Log

<u>Rev. #</u>	<u>Date</u>	<u>Page(s)</u>	<u>Revision(s)</u>
R0	05/16/17	N/A	Original Report Issue
R1	05/17/17	All	Removed ASTM E283 Data and References
R2	05/26/17	Appendix D	Corrected drawings



H0258.04-303-11-R2

## Appendix A



H0258.04 -303-11

### Appendix A

**Instrumentation:**

Instrument	Manufacturer	Model	Description	ATI Number	Date of Calibration
Data Acquisition Chassis	National Instruments	PXI-1033	Data Acquisition Chassis	INT00392	10/16
Data Acquisition Card	National Instruments	PXI-4462	Data Acquisition Card	INT00395	10/16
Data Acquisition Card	National Instruments	PXI-4462	Data Acquisition Card	INT00396	10/16
Data Acquisition Card	National Instruments	PXI-4462	Data Acquisition Card	INT00397	10/16
Source Room Microphone	PCB Piezotronics	378B20	Microphone and Preamplifier	INT00249	04/17
Source Room Microphone	PCB Piezotronics	378B20	Microphone and Preamplifier	INT00250	04/17
Source Room Microphone	PCB Electronics	378B20	Microphone and Preamplifier	INT00251	04/17
Source Room Microphone	PCB Piezotronics	378B20	Microphone and Preamplifier	INT00252	04/17
Source Room Microphone	PCB Piezotronics	378B20	Microphone and Preamplifier	INT00248	04/17
Receive Room Microphone	PBC Piezotronics	378B20	Microphone and Preamplifier	INT00229	03/17
Receive Room Microphone	PCB Piezotronics	378B20	Microphone and Preamplifier	INT00230	03/17
Receive Room Microphone	PCB Piezotronics	378B20	Microphone and Preamplifier	INT00231	03/17
Receive Room Microphone	PCB Piezotronics	378B20	Microphone and Preamplifier	INT00232	03/17
Receive Room Microphone	PCB Piezotronics	378B20	Microphone and Preamplifier	INT00233	03/17
Receive Room Environmental Indicator	Comet	T7510	Receive Room	INT00299	10/16
Source Room Environmental Indicator	Comet	T7510	Source Room	INT00300	10/16
Microphone Calibrator	Norsonic	1251	Pistonphone Calibrator	00288	04/16

\*- Note: The calibration frequency for this equipment is every two years per the manufacturer's recommendation.

**Test Chamber:**

	Volume	Description
Receive Room	231 m <sup>3</sup>	Rotating vane and stationary diffusers Temperature and humidity controlled Isolation pads under the floor
Source Room	200 m <sup>3</sup>	Stationary diffusers only and humidity controlled

	Maximum Size	Description
TL Test Opening	4.27 m wide by 3.05 m high	Vibration break between source and receive rooms

N/A-Non Applicable





H0258.04-303-11-R2

## **Appendix B**

### **Complete Test Results**



### AIRBORNE SOUND TRANSMISSION LOSS

ASTM E 90

<b>Test Date</b>	04/19/17						
<b>Data File No.</b>	H0258.04						
<b>Client</b>	CR Laurence Co., Inc.						
<b>Description</b>	Series/Model: 487-AR Aluminum Office Wall with 1/4" laminate, 3-1/2" air space, 3/8" laminate						
<b>Specimen Area</b>	4.12 m <sup>2</sup>	Receive Temp.	22.8 °C		Source Temp.	22.2 °C	
<b>Technician</b>	Bradlay Hunt	Receive Humidity	54%		Source Humidity	56%	

Freq (Hz)	Background SPL (dB)	Absorption (m <sup>2</sup> )	Source SPL (dB)	Receive SPL (dB)	Specimen TL (dB)	95% Confidence Limit	Number of Deficiencies
80	35.8	5.1	104	74	30.5	1.57	-
100	31.9	5.0	106	78	28.1	1.66	-
125	38.1	5.3	105	72	33.3	0.99	0
160	42.8	5.0	103	67	36.3	0.82	0
200	36.6	6.4	105	70	34.8	0.92	2
250	22.0	6.5	106	63	42.7	0.67	0
315	16.8	7.0	106	64	40.1	0.31	3
400	17.8	6.1	107	66	39.5	0.61	7
500	19.8	5.4	108	63	44.2	0.67	3
630	16.9	5.7	106	58	46.5	0.36	2
800	17.6	5.9	106	54	49.9	0.31	0
1000	10.7	6.2	107	56	49.4	0.39	1
1250	7.7	6.5	106	56	48.2	0.24	3
1600	6.0	7.0	103	54	47.4	0.25	4
2000	7.7	8.1	102	51	48.1	0.25	3
2500	7.1	8.6	101	49	49.5	0.20	1
3150	5.9	9.7	101	45	52.6	0.11	0
4000	5.8	11.6	99	38	56.6	0.30	0
5000	5.8	14.4	99	33	60.3	0.30	-

**STC Rating**      **47**      *(Sound Transmission Class)*  
**Deficiencies**      **29**      *(Sum of Deficiencies)*  
**OITC Rating**      **40**      *(Outdoor-Indoor Transmission Class)*

- Notes:**
- 1) Receive Room levels less than 5 dB above the Background levels are red.
  - 2) Specimen TL levels listed in red indicate the lower limit of the transmission loss.
  - 3) Specimen TL levels listed in green indicate that there has been a filler wall correction applied

**AIRBORNE SOUND TRANSMISSION LOSS**  
ASTM E 90

<b>Test Date</b>	04/19/17					
<b>Data File No.</b>	H0258.04					
<b>Client</b>	CR Laurence Co., Inc.					
<b>Description</b>	Series/Model: 487-AR Aluminum Office Wall with 1/4" laminate, 3-1/2" air space, 3/8" laminate					
<b>Specimen Area</b>	4.12 m <sup>2</sup>	Receive Temp.	22.8 °C		Source Temp.	22.2 °C
<b>Technician</b>	Bradlay Hunt	Receive Humidity	54%		Source Humidity	56%

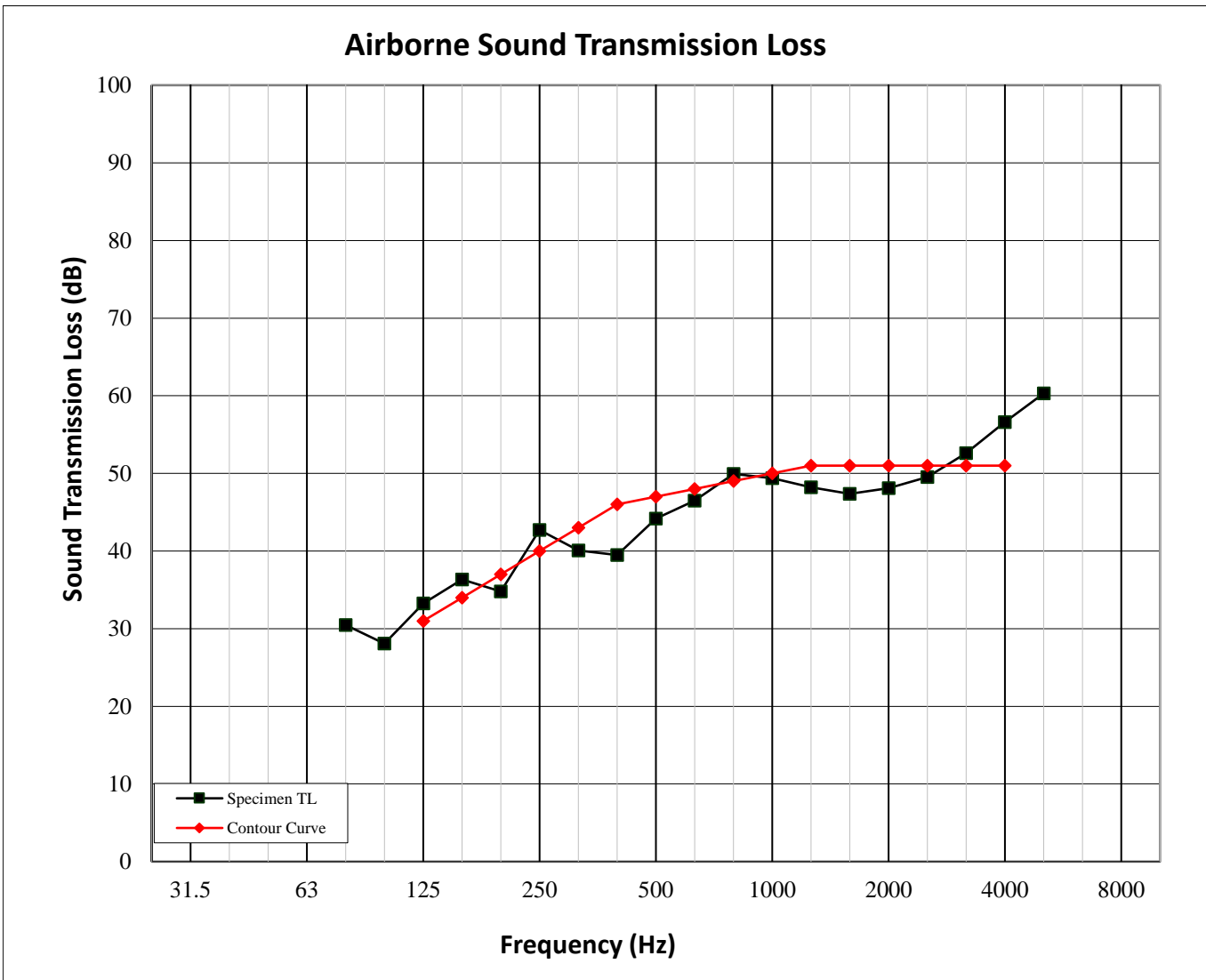

**Appendix C**

**Photographs**



**Receive Room View of Installed Specimen**



**Source Room View of Installed Specimen**



H0258.04-303-11-R2

## **Appendix D**

### **Drawings**

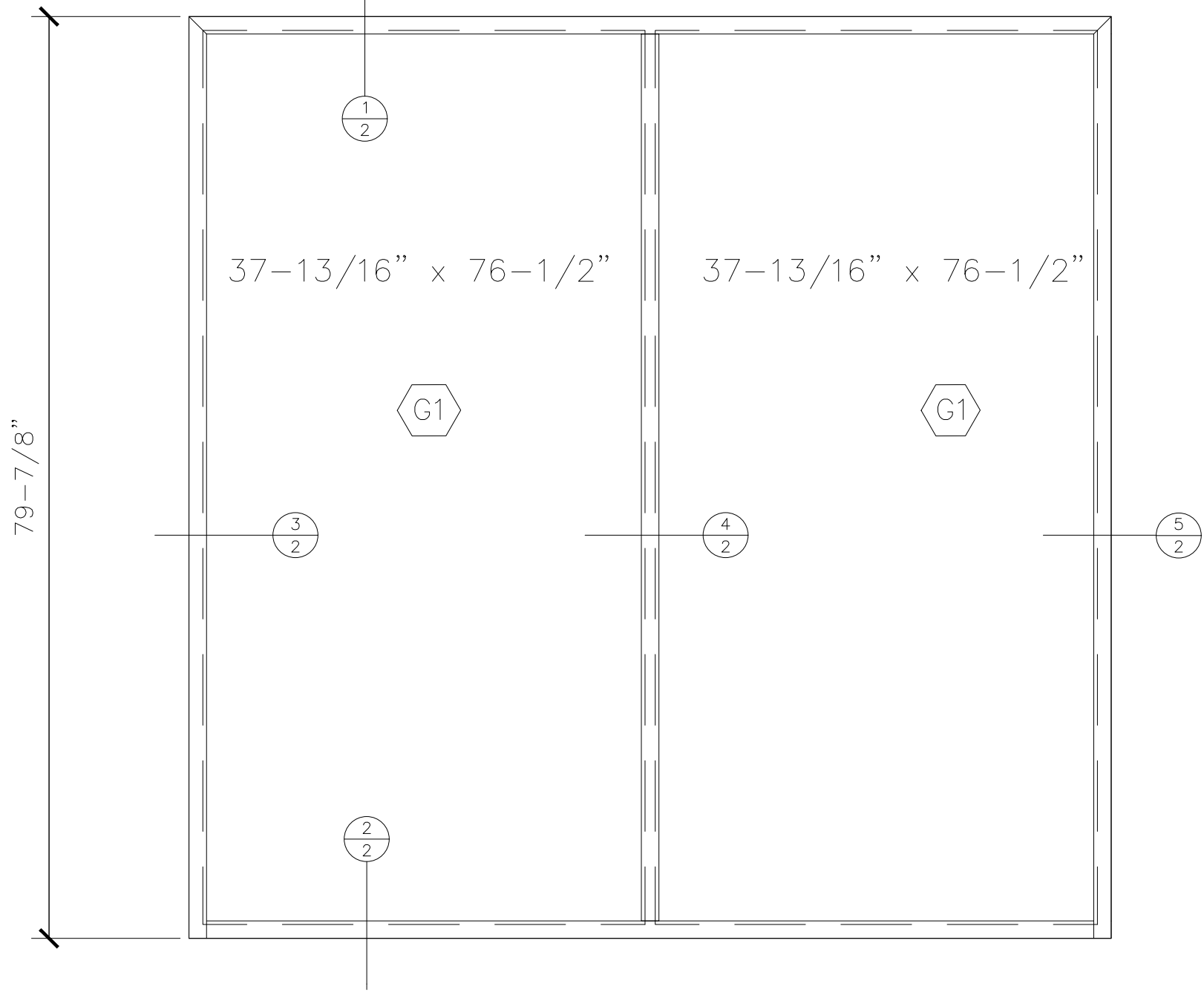

C1	FRAME	487X201	487 HEAD, JAMB, SILL MULLIONS
C2		487X203	487 VERTICAL/HORIZONTAL MULLIONS
C3		487X202	487 FLOOR TRACK
C4		487X215	487 FACE CAP- 1-1/2"
C6		487X214	487 GLAZING ADAPTOR
F1	FASTENERS	20061601	# 6-20X1/2 P.H.P. TEK SCREWS
F2		-----	# 8 X 2-1/2 DRY WALL SCREWS
W1	WTHR STRIP	NP718	INTERIOR SPONGE GASKET
W2		NP225	VINYL GLAZING GASKET
G1	GLASS		1/4" LAMINATED GLASS
G2		SB514	NEOPRENE SETTING BLOCK
H1	HARDWARE	487C1	487 SERIES 90 DEG. CLIP
H2		487C2	487 SERIES "T" CLIP
H3		TCI-93170X330	TREMCO ACOUSTICAL CURTAINWALL SEALANT

REVISIONS

**CRL**  
 C.R. LAURENCE CO.  
 ARCHITECTURAL PRODUCTS  
 2100 E. 38TH Street, Los Angeles, CA 90058  
 www.crlaurence.com

Job Name:  
 487 SERIES  
 OFFICE PARTITION  
 ACOUSTIC CONTROL SYSTEM

Glazing Contractor:

DATE: 12.20.2016  
 DRAWN BY: GDO  
 CHECKED BY: XX  
 SCALE: AS SHOWN  
 JOB #: PTC

SHT 1 OF 3

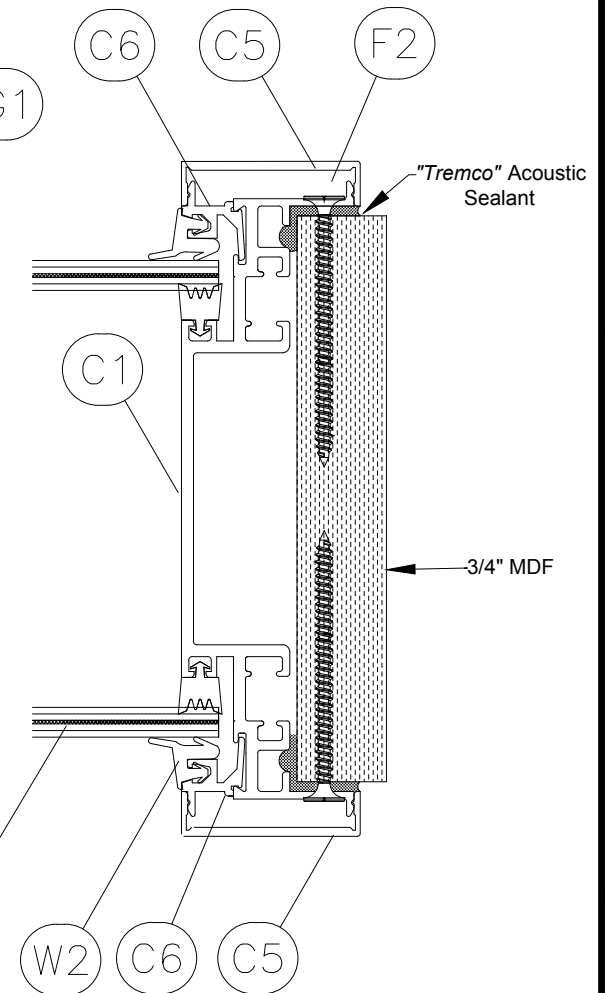
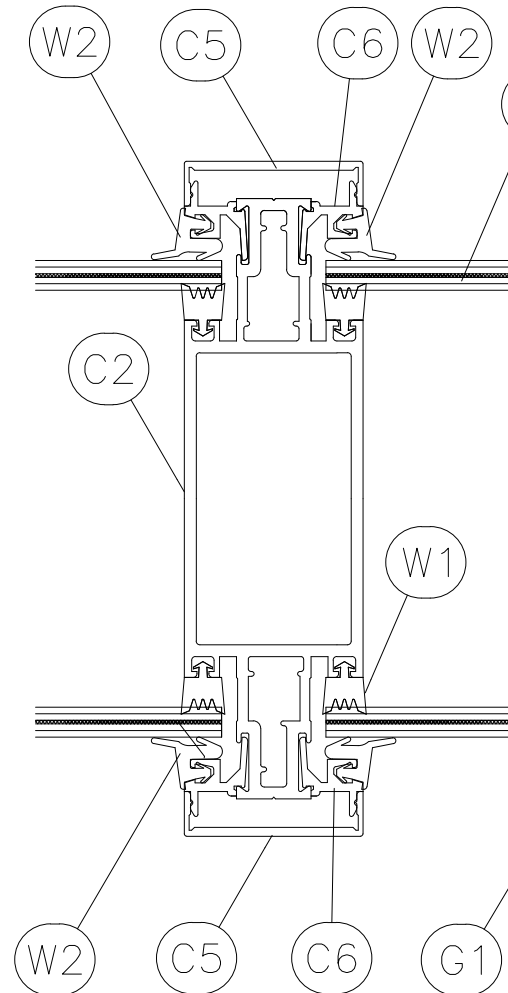
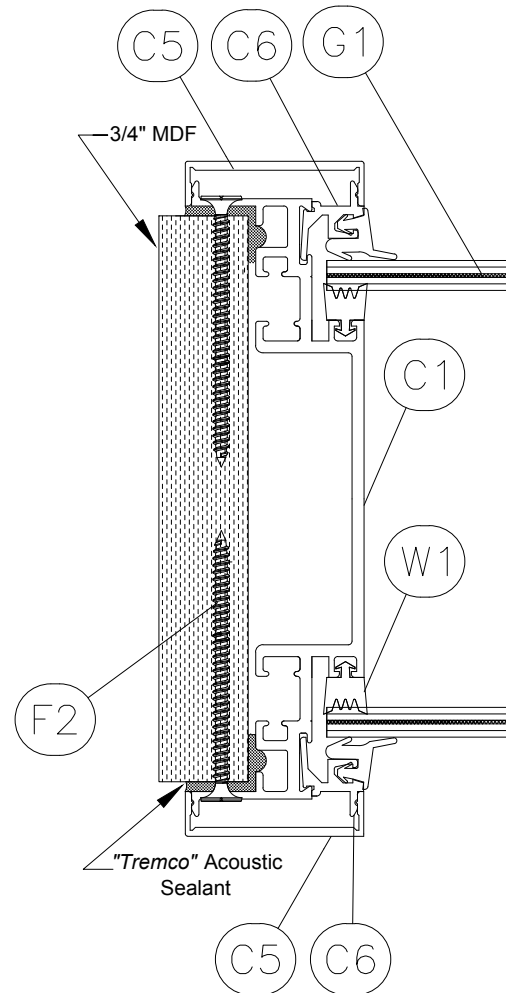
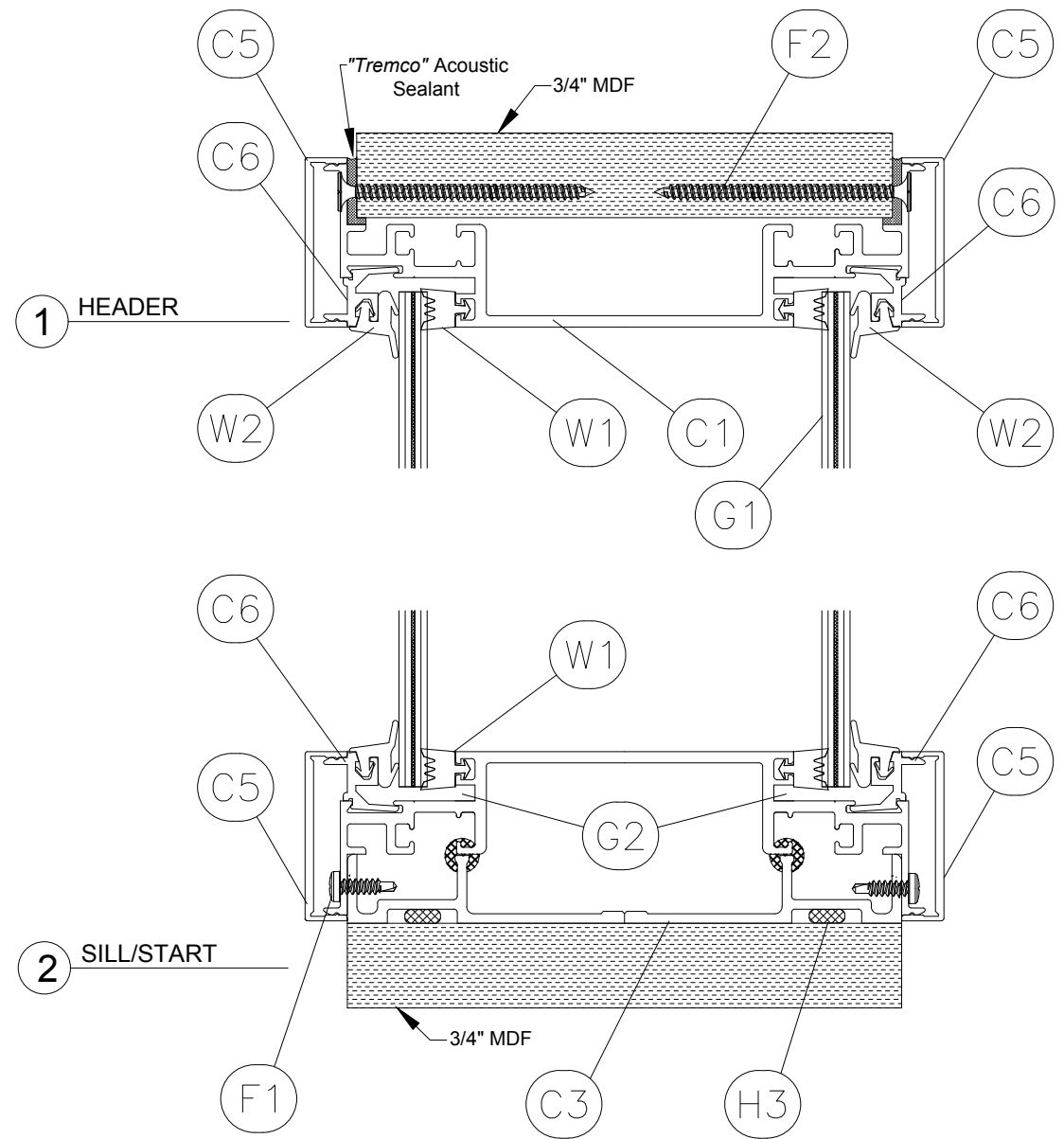

  
**CRL**  
 C.R. LAURENCE CO.  
 ARCHITECTURAL PRODUCTS  
 2100 E. 38TH Street, Los Angeles, CA 90058  
 www.crlaurence.com

Job Name:  
 487 SERIES  
 OFFICE PARTITION  
 ACOUSTIC CONTROL SYSTEM

DATE:	12.20.2016
DRAWN BY:	GDO
CHECKED BY:	XX
SCALE:	AS SHOWN
JOB #:	PTC

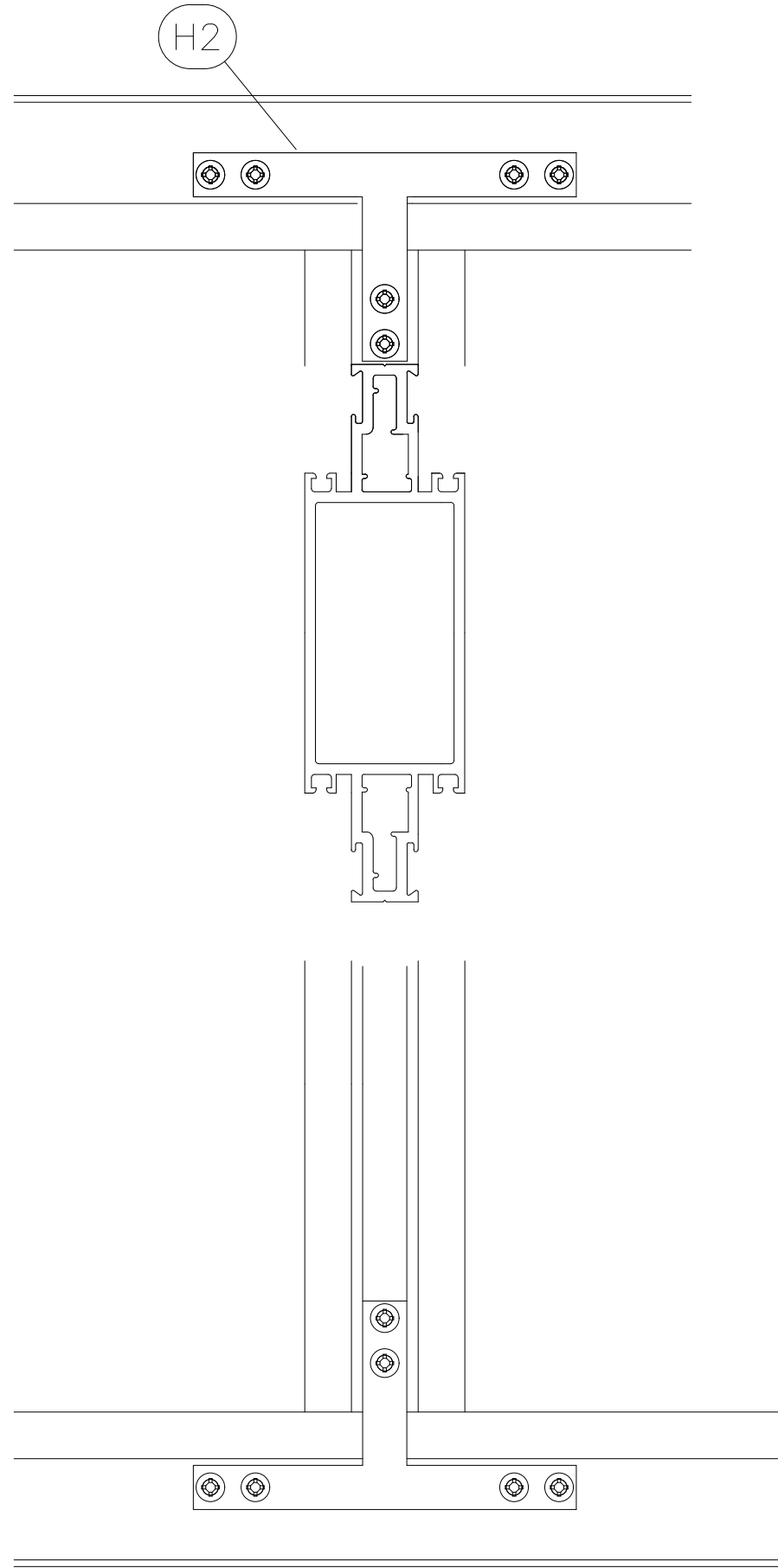
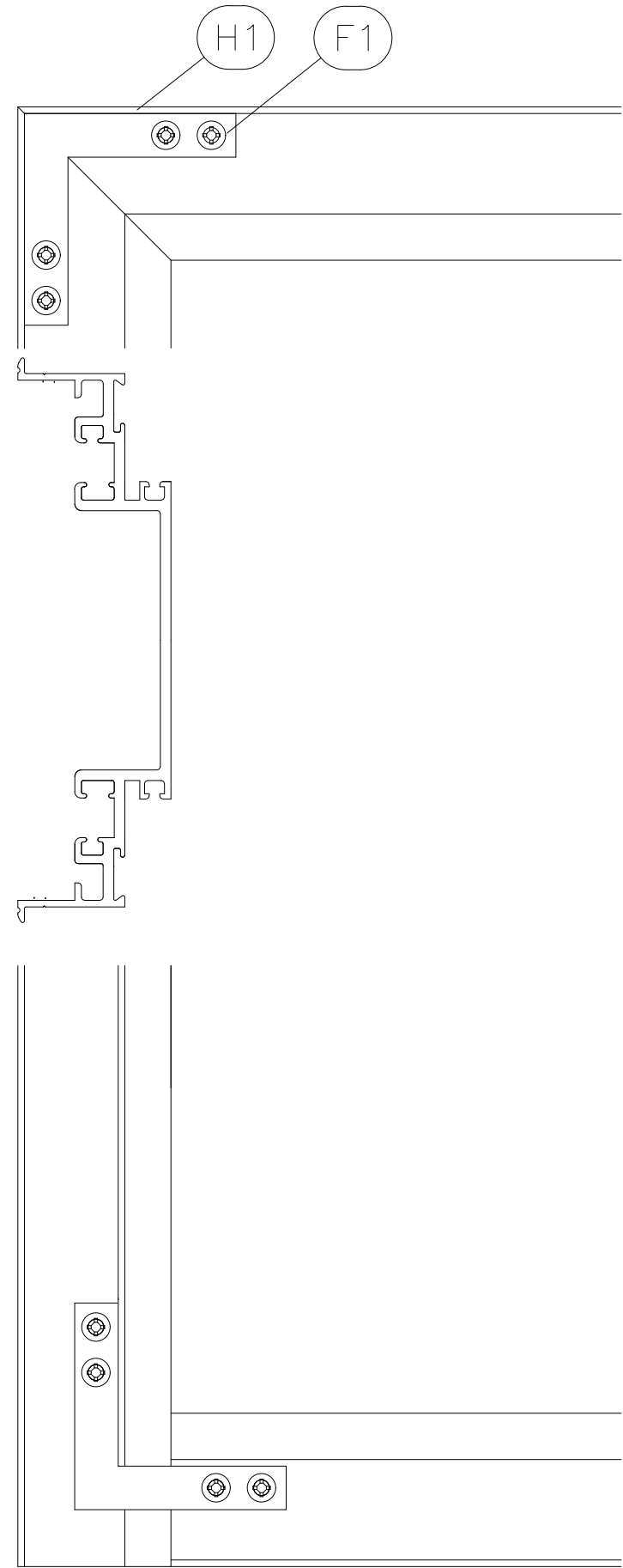

REVISIONS



**CRL**

C.R. LAURENCE CO.

ARCHITECTURAL PRODUCTS

2100 E. 38TH Street, Los Angeles, CA 90058

www.crlaurence.com

Job Name:

487 SERIES  
OFFICE PARTITION  
ACOUSTIC CONTROL SYSTEM

DATE: 9-9-2014

DRAWN BY: GDO

CHECKED BY: XX

SCALE: AS SHOWN

JOB #: PTC411852

SHT 3 OF 3