

Optional Reinforcement Back-up Plates
CRL Cat No. 2302711

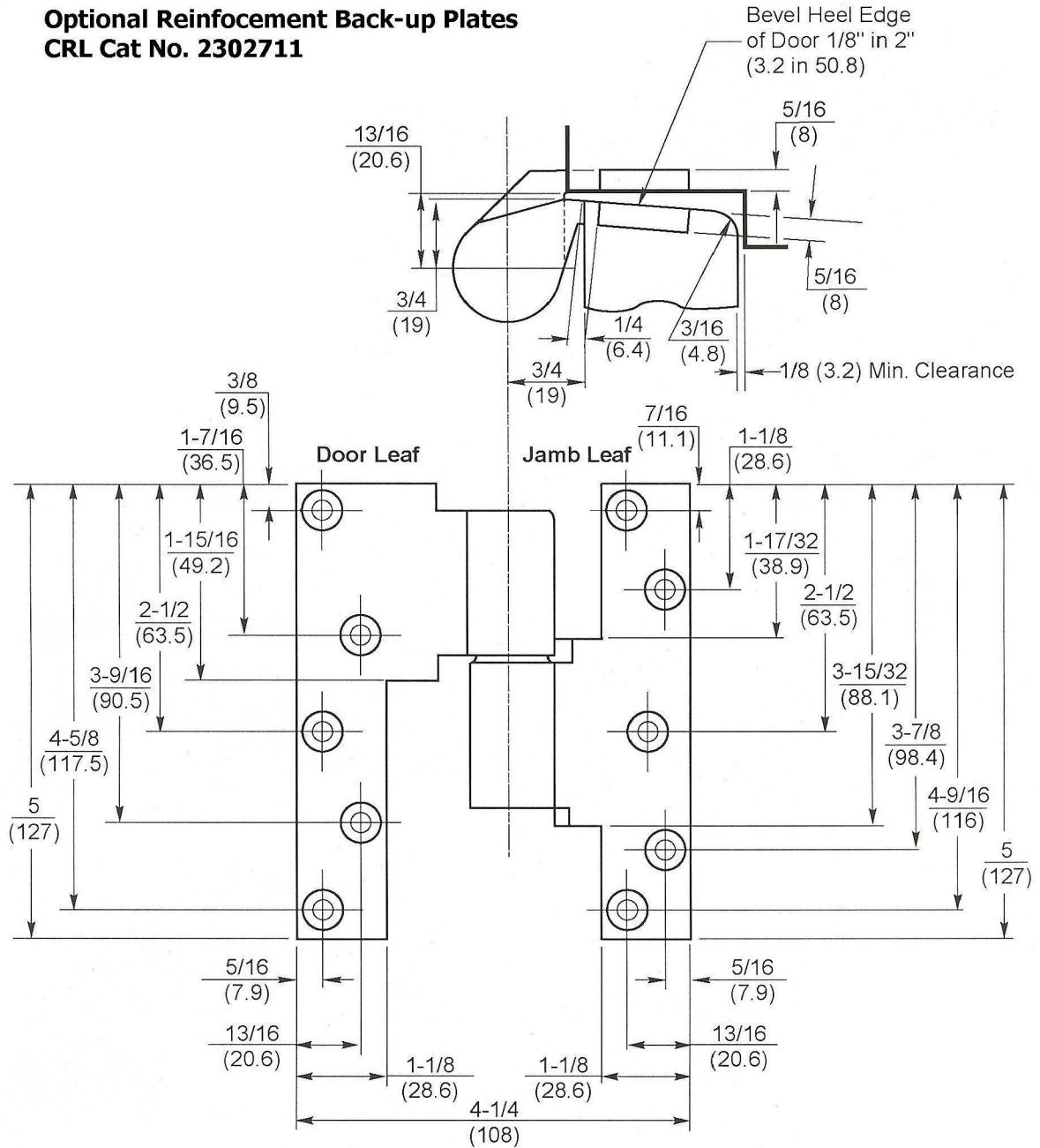

Notes:

1. Do not scale drawing - Template drawing for reference only.
2. Dimensions are given in inches (mm).
3. Pivot drilled for 1/4-20 x 5/8" FHMS.
4. Right Hand (Left Hand - Reverse Bevel) Shown.

CRL19
3/4" OFFSET
INTERMEDIATE PIVOT

CRL C.R. Laurence Co., Inc.